

This electronic thesis or dissertation has been downloaded from the King's Research Portal at <https://kclpure.kcl.ac.uk/portal/>



## Patient-Ventilator Interaction in Domiciliary Non-invasive Ventilation

Ramsay, Michelle Clare

*Awarding institution:*  
King's College London

The copyright of this thesis rests with the author and no quotation from it or information derived from it may be published without proper acknowledgement.

### END USER LICENCE AGREEMENT



Unless another licence is stated on the immediately following page this work is licensed

under a Creative Commons Attribution-NonCommercial-NoDerivatives 4.0 International

licence. <https://creativecommons.org/licenses/by-nc-nd/4.0/>

You are free to copy, distribute and transmit the work

Under the following conditions:

- Attribution: You must attribute the work in the manner specified by the author (but not in any way that suggests that they endorse you or your use of the work).
- Non Commercial: You may not use this work for commercial purposes.
- No Derivative Works - You may not alter, transform, or build upon this work.

Any of these conditions can be waived if you receive permission from the author. Your fair dealings and other rights are in no way affected by the above.

### Take down policy

If you believe that this document breaches copyright please contact [librarypure@kcl.ac.uk](mailto:librarypure@kcl.ac.uk) providing details, and we will remove access to the work immediately and investigate your claim.

# Patient-Ventilator Interaction in Domiciliary Non-Invasive Ventilation

---

By Dr Michelle Ramsay (Student Number 98001578/4)

Department of Asthma, Allergy and Lung Biology

King's College London

PhD Thesis

2017

## Acknowledgements

This thesis would not have been possible without the assistance of a great many people and for whose support I will be forever grateful.

I would firstly like to thank my supervisors Professor Nicholas Hart and Professor Anita Simonds for this incredible opportunity to explore the fascinating world of patient-ventilator interaction that has become my life's passion. I would also like to thank them for their inspiration in this new world of academia, for their time and patience in assisting me through my challenges and for their unwavering faith in me to see it through.

None of this work could have taken place without the support of my colleagues and concurrent research fellows Dr Eui-Sik Suh, Dr Swapna Mandal, Dr Patrick Murphy, Dr Bronwen Connolly and Dr Victoria MacBean. Their friendship, discussions and understanding made coping with the sleep deprivation possible.

I am greatly indebted and was privileged to work alongside the London respiratory muscle group who were truly inspirational and without their many academic achievements in the field of respiratory physiology this PhD would not have been possible. As was said at many a research meeting 'we stand on the shoulders of giants'.

Special thanks must go to my mother Lynne Ramsay and brother John Ramsay for all their tireless support throughout the years and endless proof reading for typing errors. I am truly thankful for them always being the first to volunteer and recruiting many of their friends to take part in my studies. I must also thank my mother for belief she has had in me, the opportunities she has afforded me and taking care of my daughter Jessica, so that I could finally attend my PhD viva, when she surprised me arriving the day before my original viva date.

Lastly, a huge thank you to my husband David Bonsall, who sacrificed so many a holiday and weekend to enable me the space and time to complete this life's work. For his unwavering support and spreadsheet expertise which ultimately has enabled this dream to be a reality.

## Declaration

Permission to perform the research studies performed as part of this PhD thesis from ethics and research and development was obtained by myself and Professor Nicholas Hart. All patient and subject recruitment and consenting was performed either by myself or a member of the Lane Fox respiratory research team (Dr Swapna Mandal and Dr Eui-Sik Suh). All data collection, data analysis and data reporting described in this thesis was performed by myself unless otherwise stated. The intellectual concept for the randomised control trial examining a physiological set-up of home mechanical ventilation on neural respiratory drive and patient-ventilator asynchrony compared to standard physician led practice and study design belongs to Professor Nicholas Hart, Professor Anita Simonds, Professor John Moxham, myself and the members of the London respiratory muscle group (Dr Gerrard Rafferty, Professor Mike Polkey, Dr Nicholas Hopkins, Dr Joerg Steier, Dr Patrick Murphy, Dr Caroline Jolley, Dr Victoria MacBean, Dr Bronwen Connolly). The addition of examining the impact of patient-ventilator asynchrony on sleep quality came from discussions with Dr Ian Smith at my upgrade viva. The intellectual concept and study design of examining the impact of posture on neural respiratory drive and the impact of ventilator trigger delay on patient comfort belong to myself, Professor Nicholas Hart and the London respiratory muscle group.

## Table of Contents

Appendices.....	12
List of Tables.....	13
List of Figures.....	16
Glossary.....	22
Abstract.....	25
Chapter 1 Introduction .....	26
1.1 A History of Patient Ventilator Interaction.....	26
1.2 Mechanisms of respiratory failure.....	27
1.3 Assessment of the patient in chronic respiratory failure.....	30
1.3.1 Clinical Assessment .....	30
1.4 Clinical investigations .....	31
1.4.1 Arterial blood gas (ABG) measurement .....	31
1.4.2 Lung function tests .....	32
1.4.3 Non-invasive and Invasive Respiratory Muscle tests.....	33
1.4.4 Peak Cough Flow .....	34
1.4.5 Invasive respiratory muscle tests .....	34
1.4.6 Imaging .....	36
1.4.7 Overnight physiological monitoring .....	36
1.5 The role of domiciliary non-invasive ventilation in chronic respiratory failure .....	36
1.5.1 Neuromuscular Disease (NMD) .....	37

1.5.2 Chronic Obstructive Pulmonary Disease (COPD).....	39
1.5.3 Obesity Hypoventilation Syndrome (OHS) .....	41
1.6 Non-invasive ventilation (NIV) failure .....	43
1.7 Patient Ventilator Interaction in Mechanical Ventilation .....	44
1.7.1 Defining patient ventilator synchrony .....	44
1.7.2 Difficulties in assessing the prevalence of patient-ventilator asynchrony .....	45
1.7.3 Difficulties in reporting the prevalence of patient-ventilator asynchrony .....	46
1.7.4 Critique of the current asynchrony index.....	46
1.7.5 Prevalence of patient-ventilator asynchrony in invasive ventilation .....	47
1.7.6 Prevalence of patient-ventilator asynchrony in non-invasive ventilation.....	49
1.8 Types of patient-ventilator asynchrony .....	50
1.9 Extent of the problem –a survey of patient opinion on patient-ventilator asynchrony.....	51
1.10 Potential consequences of patient-ventilator asynchrony .....	55
1.10.1 Ultrastructural injury to respiratory muscles .....	55
1.10.2 Increases work of breathing .....	55
1.10.3 Impairs pulmonary mechanics and gas exchange .....	55
1.10.4 Induces patient discomfort.....	56
1.10.5 Increases sleep disruption.....	56
1.10.6 Increases time spent on mechanical ventilation.....	57
1.11 Summary.....	57
Chapter 2 Material and Methods .....	58

2.1 Ethical Approval.....	58
2.2 Subjects .....	58
2.3 Anthropometrics.....	58
2.3.1 Measurement of Fat Free Mass .....	59
2.4 Arterial blood gases .....	59
2.5 Questionnaires.....	59
2.5.1 Epworth Sleepiness Scale (ESS) .....	60
2.5.2 Fatigue Severity Score (FSS).....	60
2.5.3 Hospital anxiety and depression score (HADS) .....	60
2.5.4 Severe Respiratory Insufficiency Questionnaire (SRI).....	60
2.5.5 36-Item Short Form Health Survey (RAND-36).....	61
2.5.6 Visual Analogue Scores (VAS).....	61
2.6 Pulmonary function and respiratory muscle testing.....	62
2.6.1 Pneumotachography flow assessment.....	62
2.6.2 Respiratory Muscle Strength .....	62
2.7 Measures of Neural Respiratory Drive .....	63
2.7.1 Measurement of surface parasternal EMG (sEMGpara) .....	63
2.7.2 Difficulties encountered in using surface parasternal EMG measurements for continuous monitoring .....	65
2.7.3 Measurement of Diaphragm EMG.....	67
2.7.4 Pressure-volume characteristics of the nasogastric catheter balloons.....	69
2.7.5 Pressure Transducer calibration .....	71

2.7.6 Testing for intrinsic delays between pressure and flow responses.....	71
2.7.7 Frequency Response of the Recording System.....	73
2.8 Assessment of Sleep disordered Breathing .....	74
2.8.1 Overnight oximetry and capnography .....	74
2.8.2 Respiratory Inductance Plethysmography .....	74
2.8.3 Mask or nasal Pressure monitoring.....	75
2.8.4 Respiratory Polygraphy .....	75
2.8.5 Overnight Polysomnography .....	75
2.8.6 Scoring sleep stages .....	76
2.8.7 Scoring arousals.....	77
2.8.8 Sleep quality measures .....	78
2.8.9 Scoring respiratory events.....	78
2.9 Non-invasive detection of patient-ventilator asynchrony.....	79
2.9.1 Trigger asynchrony- Ineffective efforts.....	81
2.9.2 Trigger asynchrony- Autotriggering.....	82
2.9.3 Defining double triggering.....	83
2.9.4 Defining multiple triggering.....	84
2.9.5 Defining premature expiratory cycling asynchrony .....	85
2.9.6 Defining extended expiratory cycling asynchrony .....	86
2.9.7 Defining autocycling .....	87
2.10 Inter-rater reliability in detection on patient ventilator asynchrony .....	88

2.10.1 Scoring PVA in association with sleep and wakefulness during the overnight study .....	90
2.10.2 Acquisition and storage of Data .....	91
2.10.3 Statistical Analysis.....	91
 Chapter 3 The effect of posture on neural respiratory drive to parasternal intercostal and diaphragm muscles in healthy subjects and Duchenne Muscular Dystrophy patients .....	 93
3.1 Background.....	93
3.1.1 Study hypothesis: There is a change in neural respiratory drive accompanying changes in body position from 45° upright.....	93
3.2 Material and Methods .....	94
3.3 Results .....	95
3.3.1 Subject demographics .....	95
3.3.2 sEMGpara measurements in healthy subjects.....	97
3.3.3 EMGdi signal measurement in healthy subjects .....	99
3.3.4 Comparison between sEMGpara%max and EMGdi%max in healthy subjects.....	101
3.3.5 sEMGpara signals in Duchenne Muscular Dystrophy patients .....	104
3.4 Discussion.....	108
3.4.1 Critique of the method .....	108
3.4.2 Significance of findings.....	109
3.5 Conclusion .....	111
 Chapter 4 Pilot randomised controlled trial of physiological surface second intercostal parasternal electromyography (sEMGpara) set up of home mechanical ventilation compared to standard physician led set up .....	 113

4.1 Introduction .....	113
4.1.1 Study Hypothesis.....	114
4.2 Methods .....	115
4.2.1 Patients.....	115
4.2.2 Detailed Patient Eligibility Criteria .....	115
4.2.3 Study Design .....	116
4.2.4 Primary Outcome.....	116
4.2.5 Home mechanical ventilation set up.....	116
4.2.6 Measurements.....	118
4.2.7 Analysis and statistics .....	119
4.3 Results .....	120
4.3.1 Recruitment .....	120
4.3.2 Detailed baseline patient anthropometrics .....	121
4.3.3 Ventilator settings between the physiological HMV set up and physician led HMV set up	124
4.3.4 Prevalence of patient-ventilator asynchrony .....	126
4.3.5 Primary outcome: Adherence to HMV therapy at 3 months.....	129
4.3.6 Secondary outcome: Gas exchange at 3 months .....	131
4.3.7 Secondary outcome: Changes in respiratory muscle loading measured by sEMGpara%max at 3 months .....	135
4.3.8 Secondary outcome: Health related quality of life measures.....	139
4.3.9 Nocturnal ventilator titration to set up HMV .....	146
4.3.10 HMV set up length of hospital stay.....	147

4.4 Discussion.....	148
4.4.1 Main findings.....	148
4.4.2 Critique of the Method .....	149
Methods of assessment.....	151
Patient ventilator asynchrony .....	152
Type of patient ventilator asynchrony.....	153
HMV Adherence .....	154
Gas exchange.....	154
Respiratory muscle unloading .....	155
Health related quality of life .....	156
Hospital length of stay during HMV set up .....	158
4.4.3 Clinical significance of the findings.....	158
4.5 Conclusion .....	163
Chapter 5 Impact of Patient Ventilator Asynchrony on Sleep Quality .....	164
5.1 Introduction .....	164
5.2 Methods .....	165
5.2.1 Patients.....	165
5.2.2 HMV set-up.....	165
5.2.3 Nocturnal polygraphy assessment .....	166
5.2.4 Sleep analysis.....	166
5.2.5 Integrating polysomnography and respiratory polygraphy: electroencephalogram and parasternal electromyogram.....	167

5.3 Statistical Analysis .....	168
5.4 Results .....	168
5.4.1 Patient ventilator asynchrony and sleep stages.....	175
5.4.2 Patient ventilator asynchrony and sleep disruption.....	177
5.4.3 Patient ventilator asynchrony and sleep quality .....	179
5.5 Discussion.....	183
5.5.1 Main findings.....	183
5.5.2 Critique of the Method .....	183
5.6 Conclusion and clinical relevance .....	189
Chapter 6 The impact of inspiratory trigger delay on neural respiratory drive and the perception of comfort .....	191
6.1 Introduction .....	191
6.1.1 Study aims .....	192
6.2 Methods .....	192
6.2.1 Measuring inspiratory trigger delay .....	193
6.2.2 Non-invasive ventilator settings.....	197
6.2.3 Participant comfort measurements.....	198
6.2.4 Statistical analysis .....	198
6.3 Results .....	198
6.3.1 Study Participants.....	198
6.3.2 The effect of trigger delay on sEMGpara%max .....	201

6.3.3 Respiratory muscle loading in healthy subjects and COPD patients with increasing trigger delay .....	204
6.3.4 The effect of trigger delay on comfort scores.....	206
6.3.5 The relationship between respiratory muscle loading and perception of comfort.....	207
6.3.6 Considering the components of the trigger delay.....	208
6.4 Discussion.....	213
6.4.1 Main findings.....	213
6.4.2 Critique of the method .....	214
6.4.3 Respiratory muscle response to increasing inspiratory trigger delays on non-invasive ventilation.....	215
6.4.4 Patient comfort with increasing inspiratory trigger delays on non-invasive ventilation .....	217
6.4.5 Components of trigger delay .....	218
6.4.6 Applicability of measuring sEMGpara%max in healthy subjects .....	221
6.4.7 Clinical significance of the findings.....	221
6.5 Conclusion .....	222
Chapter 7 Conclusion .....	223
7.1 Utility of sEMGpara%max measurements.....	223
7.1.1 sEMGpara%max as a marker of NRD in patients and healthy subjects.....	223
7.1.2 sEMGpara%max as a marker of patient comfort .....	223
7.1.3 sEMGpara%max as a tool to measure respiratory muscle unloading during HMV .....	223
7.1.4 sEMGpara%max led set up of HMV.....	224
7.1.5 sEMGpara%max as a marker of patient- ventilator asynchrony.....	224

7.2 Patient-ventilator asynchrony what have we learnt .....	224
7.2.1 Prevalence of PVA .....	224
7.2.2 PVA in different disease groups .....	225
7.2.3 Controlling PVA with fixed bi-level ventilation settings.....	225
7.2.4 PVA and Adherence to NIV .....	227
7.2.5 PVA and Gas Exchange .....	228
7.2.6 PVA and respiratory muscle loading .....	228
7.2.7 PVA and Patient Quality of Life Measures .....	228
7.2.8 PVA and Sleep Efficiency .....	229
7.3 Inspiratory trigger delay .....	230
7.4 Conclusion .....	231
7.5 Future work .....	232
References.....	233

## Appendices

Appendix 1: Physician led protocolised set-up of HMV a) COPD patients, b) OSA/OHS patients and c) NMD patients.....	242
Appendix 2: Intervention (sEMGpara) led HMV titration protocol.....	245
Appendix 3: Outline of study timings.....	247
Appendix 4: Trial Consort Diagram.....	248
Appendix 5: PSG scoring agreement of 10 studies between myself (MR) and an ASA accredited sleep technician.....	249
Appendix 6: Patient Ventilator Asynchrony Questionnaires.....	250
Appendix 7: Publications during PhD training .....	256

## List of Tables

<b>Table 1: A summary of the amounts of asynchrony reported during invasive ventilation for acute respiratory failure (&lt;24hrs) in pressure support mode</b> .....	47
<b>Table 2: A summary of the amounts of asynchrony reported during invasive ventilation for respiratory failure (&gt;24hrs) in pressure support mode</b> .....	48
<b>Table 3: A summary of the amounts of asynchrony reported during non-invasive ventilation in pressure support mode</b> .....	49
<b>Table 4: Patients surveyed demographics</b> .....	52
<b>Table 5: Ventilator settings in different patient groups on HMV</b> .....	53
<b>Table 6 Agreement of triggering asynchrony between 2 independent scorers</b> .....	89
<b>Table 7 Agreement of cycling asynchrony between 2 scorers</b> .....	89
<b>Table 8: Healthy subjects demographics for the total enrolled and for those with adequate signal in all 5 postures</b> .....	96
<b>Table 9: sEMGpara%max signals obtained in the 5 different postures including the change from the standardised 45 degree posture</b> .....	97
<b>Table 10: Comparison between baseline sEMGpara%max signals obtained at 45 degrees in healthy subjects that had reproducible and non-reproducible signals in all 5 postures studied.</b> .....	99
<b>Table 11: EMGdi%max signals obtained in the 5 different postures in healthy subjects including the change from the standardised 45 degree posture</b> .....	100
<b>Table 12: Initial patient baseline characteristics: categorised by physiological and physician led HMV set up</b> .....	121
<b>Table 13: Patient baseline characteristics: categorised by disease group</b> .....	122

<b>Table 14: HMV ventilator settings post set up at hospital discharge: categorised by physiological and physician led HMV set up.....</b>	<b>124</b>
<b>Table 15: HMV ventilator settings post set up at hospital discharge: categorised by disease group.....</b>	<b>125</b>
<b>Table 16: Comparison between adherence to HMV in the physiological sEMGpara led set up of HMV and the physician led set up of HMV .....</b>	<b>129</b>
<b>Table 17: Change in gas exchange between the physiological sEMGpara led set up and the physician led set up of HMV during 3 months of therapy. ....</b>	<b>132</b>
<b>Table 18: Changes in neural respiratory drive between the physiological led HMV set up group and the physician led HMV set up group at baseline self-ventilating and baseline HMV set up .....</b>	<b>136</b>
<b>Table 19: Change in health related quality of life following 3 months of HMV therapy: comparison of physiological HMV set up and physician led HMV set up .....</b>	<b>140</b>
<b>Table 20: Change visual analogue scales and patient perception of patient ventilator asynchrony questionnaire following 3 months of HMV therapy: comparison of physiological HMV set up and physician led HMV set up .....</b>	<b>141</b>
<b>Table 21: Total cohort changes in health related questionnaire measures with 3 months of HMV .....</b>	<b>142</b>
<b>Table 22: Visual analogue scales and patient perception of patient ventilator asynchrony questionnaire.....</b>	<b>143</b>
<b>Table 23: Changes in HRQL measures comparing the different disease groups post 3 months of HMV .....</b>	<b>144</b>
<b>Table 24: Comparison of the number of ventilator alterations: comparison of the physician led HMV set up and the physiological led set up of HMV over the 3 months of HMV therapy .....</b>	<b>147</b>
<b>Table 25: Comparison of the length of hospital stay for initiation of HMV between the physician led HMV set up and the physiological set up of HMV .....</b>	<b>147</b>

<b>Table 26: Patient baseline characteristics .....</b>	<b>169</b>
<b>Table 27: Ventilator settings at initiation and 3 months post HMV .....</b>	<b>170</b>
<b>Table 28: Sleep quality measures recorded from full overnight polysomnography at initiation and 3 months post NIV therapy .....</b>	<b>171</b>
<b>Table 29: Nocturnal Respiratory Parameters.....</b>	<b>173</b>
<b>Table 30 : Integrated 2 minute respiratory polygraphy and 10 minute polysomnography data .....</b>	<b>174</b>
<b>Table 31 Demographics of healthy subjects.....</b>	<b>199</b>
<b>Table 32: Demographics of COPD patients .....</b>	<b>199</b>
<b>Table 33: Individual sEMGpara%max in response to increasing trigger delay in healthy subjects.....</b>	<b>202</b>
<b>Table 34: Detailed individual sEMGpara%max response to 20 increasing trigger delay settings (ms) in 4 COPD patients combined.....</b>	<b>203</b>
<b>Table 35: Breakdown of trigger delay (excluding enforced trigger delays) in both healthy subjects and COPD patients.....</b>	<b>209</b>
<b>Table 36: Impact of trigger delays on the total inspiratory time: percentage of time for which unrewarded parasternal respiratory muscle activity occurs .....</b>	<b>210</b>
<b>Table 37: Breathing characteristics when subject to trigger delay on non-invasive ventilation .....</b>	<b>211</b>

## List of Figures

<b>Figure 1: Types of Respiratory Muscle Load</b> .....	28
<b>Figure 2: The interplay of the load-capacity balance and its relationship with the ventilator to optimise ventilation in chronic respiratory failure</b> .....	30
<b>Figure 3: Equipment required to measure twitch transdiaphragmatic pressure, diaphragm and simultaneous parasternal electromyography</b> .....	35
<b>Figure 4: An example of a Twitch transdiaphragmatic pressure signal</b> .....	35
<b>Figure 5: The consequences if inappropriate levels of pressure support in COPD (removed for e-publication)</b> .....	41
<b>Figure 6: An example of adequate patient ventilator synchrony</b> .....	44
<b>Figure 7: An example of different asynchronous events as they affect the ventilator delivered breathing cycle</b> .....	51
<b>Figure 8: Proportion of patients reporting awareness of PVA in different disease groups</b> .....	54
<b>Figure 9: Positioning of second intercostals surface parasternal EMG electrodes (sEMGpara)</b> .....	64
<b>Figure 10: A representative trace of a raw sEMGpara signal with rectified RMS signal</b> .....	65
<b>Figure 11: A representative trace of a raw sEMGpara signal during tidal breathing and a maximal inspiratory manoeuvre that is used to normalise the measurement</b> .....	65
<b>Figure 12: An example of notch filter artefact affecting sEMGpara signals</b> .....	67
<b>Figure 13: Diagram example of the balloon catheter with mounted EMG electrodes</b> .....	68
<b>Figure 14: A representative trace acquired from simultaneous diaphragm and parasternal electromyography</b> .....	69
<b>Figure 15: Pressure-Volume characteristics of the oesophageal balloon catheter. Optimal range between 0.5-1.4ml.</b> .....	70

<b>Figure 16: Pressure-Volume characteristics of the gastric balloon catheter. Optimal range between 0.2-0.9ml .....</b>	<b>70</b>
<b>Figure 17: Equipment used to test for intrinsic delays between pressure and flow responses.</b>	<b>72</b>
<b>Figure 18: Raw Labchart data file demonstrating the accuracy of our pressure and flow recordings (time delay between signals &lt;0.006s) .....</b>	<b>73</b>
<b>Figure 19: Frequency response recording from a ‘pop-test’ using the gastric balloon (Yinghui Medical Technology Co., Ltd, Guangzhou, China) filled with 0.8ml of air.....</b>	<b>74</b>
<b>Figure 20: An example of the electroencephalography montage configuration according to the AASM manual for scoring sleep (removed for e-publication) .....</b>	<b>76</b>
<b>Figure 21: Example of respiratory events identified from overnight traces as defined by the SomnoNIV group. A) An example of an obstructive apnoea with preserved respiratory effort but reduction in flow. B) An example of central apnoea with an absence in respiratory effort and a reduction in flow interspersed with periods of hyperventilation (removed for epublication).....</b>	<b>79</b>
<b>Figure 22: A representative trace identifying an ‘ineffective effort’ asynchronous event .....</b>	<b>81</b>
<b>Figure 23: A representative trace demonstrating an ‘autotriggered’ asynchronous event .....</b>	<b>82</b>
<b>Figure 24: A representative trace of a ‘double triggering’ asynchronous event .....</b>	<b>83</b>
<b>Figure 25: A representative trace of a ‘multiple triggering’ asynchronous event .....</b>	<b>84</b>
<b>Figure 26: A representative trace of a ‘premature expiratory cycling’ asynchronous event .....</b>	<b>86</b>
<b>Figure 27: A representative trace of a ‘delayed expiratory cycling’ asynchronous event .....</b>	<b>87</b>
<b>Figure 28: A representative trace of an ‘autocycling’ asynchronous event .....</b>	<b>88</b>
<b>Figure 29: Bland-Altman comparison of (A) Ineffective efforts and (B) Auto-triggering asynchrony.....</b>	<b>90</b>

**Figure 30: The proportion of patients in whom an adequate phasic inspiratory sEMGpara signal was detected in each posture .....96**

**Figure 31: Change in sEMGpara%max with 5 different postures A) Actual sEMGpara%max measurements B) change in sEMGpara%max from 45 degree position (gold standard).....98**

**Figure 32: Change in EMGdi%max in healthy subjects with 5 different postures A) Actual EMGdi%max measurements B) change in EMGdi%max from 45 degree position (gold standard).....101**

**Figure 33: Comparison between EMGdi%max and sEMGpara%max obtained in 4 healthy individuals during 5 different postures (45 degrees semi-recumbent, lying flat, lying on the right hand side, lying of the left hand side and sitting at 90 degrees).....102**

**Figure 34: Bland-Altman analysis of agreement between sEMGpara%max and EMGdi%max signals in all 5 postures in 4 healthy subjects (A-45 degrees semi-recumbent, B-flat, C-lateral right hand side, D-lateral left hand side, E-90 degrees sitting).....102**

**Figure 35: Relationship observed between the change in sEMGpara%max and EMGdi%max from a standard (45 degree posture) across the 4 other postures. ....104**

**Figure 36: Neural respiratory drive measured by sEMGpara%max in A) 45 degrees (semi-recumbent) posture, B) Flat posture, C) Right hand side posture, D) Left hand side posture, E) 90 degree posture during tidal breathing in 11 healthy subjects and 4 Duchenne Muscular Dystrophy patients. ....105**

**Figure 37: Changes in sEMGpara%max signals measured in Duchenne Muscular Dystrophy patients in 5 different postures .....106**

**Figure 38: Relationships between sEMGpara%max and A) Body mass index (BMI), B) Forced expiratory volume in 1 sec percentage predicted (FEV1%pred), C) Forced Vital Capacity percentage predicted (FVC).....107**

**Figure 40: Prevalence of patient ventilator asynchrony during a) the initiation of HMV and b) following 3 months HMV therapy .....127**

<b>Figure 41: Prevalence of patient ventilator asynchrony at initiation of HMV and 3 months post HMV therapy in a) COPD patients, b) ORRF patients and c) NMD-CWD patients.....</b>	<b>128</b>
<b>Figure 42: Relationship between patient ventilator asynchronous breaths at 3 months and average daily adherence to HMV at 3 months (n=32) .....</b>	<b>130</b>
<b>Figure 43: Relationship between the change in patient ventilator asynchronous breaths and the average daily adherence to HMV at 3 months (n=32) .....</b>	<b>131</b>
<b>Figure 44: Relationship between the changes in daytime arterial oxygenation and the changes in patient ventilator asynchrony with 3 months of HMV .....</b>	<b>133</b>
<b>Figure 45: Relationship between the changes in daytime arterial carbon dioxide and the changes in patient ventilator asynchrony with 3 months of HMV .....</b>	<b>133</b>
<b>Figure 46: The relationship between patient ventilator asynchrony and nocturnal oxygen saturations at a) initiation and b) 3 months post HMV therapy .....</b>	<b>134</b>
<b>Figure 47: The relationship between patient ventilator asynchrony and nocturnal transcutaneous carbon dioxide levels at a) initiation and b) 3 months post HMV therapy .....</b>	<b>134</b>
<b>Figure 48: Changes in neural respiratory drive as measured by sEMGpara%max between the physician led and the physiological led set up of HMV over the 3 months of HMV .....</b>	<b>138</b>
<b>Figure 49: Relationship between the change in respiratory muscle unloading and patient ventilator asynchrony following 3 months of HMV .....</b>	<b>139</b>
<b>Figure 50: The relationship between changes in the SGRQ scores and changes in patient ventilator asynchrony levels following 3 months of HMV therapy .....</b>	<b>145</b>
<b>Figure 51: The relationship between changes in the anxiety domain of the SRI questionnaire and changes in patient ventilator asynchrony levels following 3 months of HMV therapy .....</b>	<b>146</b>
<b>Figure 52: Two examples of double triggering occurring when considering only the RIP chest and abdominal bands related to two different phenomenon a) A prematurely cycled breath with ongoing patient inspiratory effort to trigger a second ventilator delivered breath, b) A patient triggered breath followed by an non-patient triggered (auto-triggered) breath .....</b>	<b>160</b>

<b>Figure 53: Two inspiratory efforts apparent with sEMGpara but not with RIP chest and abdominal bands each followed by a ventilator triggered breath (obtained from a Duchenne muscular dystrophy patient) .....</b>	<b>162</b>
<b>Figure 54: Box Plots showing the changes in sleep stage between first night and 3 months post HMV therapy initiation .....</b>	<b>172</b>
<b>Figure 55: Box Plots showing the changes in total PVA with sleep stages between first night NIV and 3 months post NIV therapy .....</b>	<b>175</b>
<b>Figure 56: Box Plots demonstrating the changes in the most frequent triggering (ineffective efforts (IE) and auto-triggering (AT)) and cycling (premature cycling (PC) and delayed expiratory cycling, (DC)) asynchronous events at different sleep stages at initiation of HMV .....</b>	<b>176</b>
<b>Figure 57: Box Plots demonstrating the changes in the most frequent triggering (ineffective efforts (IE) and auto-triggering (AT)) and cycling (premature cycling (PC) and delayed expiratory cycling, (DC)) asynchronous events at different sleep stages post 3 month initiation of HMV .....</b>	<b>177</b>
<b>Figure 58: Box plots indicating the number of arousals per hour related to the individual types of asynchrony during the first night of NIV .....</b>	<b>178</b>
<b>Figure 59: Box plots indicating the number of arousals per hour related to the individual types of asynchrony post 3 months of NIV therapy .....</b>	<b>179</b>
<b>Figure 60: Spearman correlation between <math>PVA_{\text{sleep}}</math> and a) sleep efficiency, b) WASO and c) total sleep time during the first night of HMV .....</b>	<b>180</b>
<b>Figure 61: Spearman correlation between <math>PVA_{\text{sleep}}</math> and a) sleep efficiency, b) WASO and c) total sleep time 3 months post HMV therapy .....</b>	<b>180</b>
<b>Figure 62: Spearman correlation between <math>PVA_{\text{wake}}</math> and sleep latency at a) first night NIV and b) 3 months post NIV therapy .....</b>	<b>181</b>
<b>Figure 63: An example of the analogue delay output from the custom made NIPPY3+ ventilator measured in concert with the measures of patient ventilator interaction.....</b>	<b>194</b>

<b>Figure 64: An example of the ventilator-circuit set-up used to assess ventilator trigger delay</b>	
.....	195
<b>Figure 65: An example of the raw traces obtained from a single COPD subject at a trigger delay of a) 50ms and b) 900ms demonstrating both the delay in the ventilator pressurisation and the increased parasternal muscle recruitment.</b>	
.....	196
<b>Figure 66: Components of trigger delay identified</b>	197
<b>Figure 67: Box and Whisker plots comparing sEMGpara%max in 4 COPD patients and 14 healthy subjects self- ventilating</b>	200
<b>Figure 68: Study flow diagram a) healthy subjects and b) COPD patients</b>	200
<b>Figure 69: sEMGpara%max measured with increasing trigger delay settings in healthy subjects</b>	202
<b>Figure 70: sEMGpara%max in response to increasing trigger delay settings in COPD patients</b>	203
<b>Figure 71: Respiratory muscle loading and unloading in healthy subjects on non-invasive ventilation with increasing trigger delay</b>	204
<b>Figure 72: A graph of respiratory muscle loading and unloading in COPD patients on non-invasive ventilation with progressive increasing trigger delays</b>	205
<b>Figure 73: Combined round 1 and 2 comfort scores for a) healthy controls and b) COPD patients</b>	207
<b>Figure 74: Relationships between mean comfort perception and respiratory muscle loading in healthy subjects during a) round one and b) round two</b>	207
<b>Figure 75: Relationships between mean comfort perception and respiratory muscle loading in COPD patients during y a) round one and b) round two</b>	208
<b>Figure 76: Change in a) inspiratory flow rate b) tidal volume and c) inspiratory time observed between 10ms and 1000ms inspiratory trigger delay in healthy subjects and COPD patients</b>	212

## Glossary

ABG -arterial blood gas

AC-autocycling asynchronous event

AI-asynchrony index (all asynchronous breaths as a percentage of all breaths both requested and delivered)

AI<sub>psg</sub>-arousal index from full PSG analysis

AI<sub>total</sub>-arousal index from detailed physiological analysis only

AT-autotriggering asynchronous event

COPD-chronic obstructive pulmonary disease

CT-computer tomography

CWD-chest wall disease

DC-delayed cycling

DEXA-dual energy x-ray absorption

DMD-Duchenne muscular dystrophy

EEG-electroencephalogram

EMG-electromyogram

EMGdi-diaphragm electromyogram

EPAP-expiratory positive airway pressure

Ers- respiratory system elastance

ESS-epworth sleepiness score

FEV1- forced expiratory volume in 1 second

FRC-functional residual capacity

FSS-fatigue severity scale

FVC-forced vital capacity

HADS-hospital anxiety and depression score

HMV-home mechanical ventilation

IE- ineffective efforts asynchronous event

IPAP-inspiratory positive airway pressure

MEP-maximal expiratory pressure

MIP-maximal inspiratory pressure

NIV-non-invasive ventilation

NMD-neuromuscular disease

NRD-neural respiratory drive

OSA-obstructive sleep apnoea

OHS-obesity hypoventilation syndrome

ORRF-obesity related respiratory failure

PaO<sub>2</sub>- partial pressure of oxygen in arterial blood

PaCO<sub>2</sub>-partial pressure of carbon dioxide in arterial blood

PC-premature cycling asynchronous event

PCF-peak cough flow

PCV-pressure control ventilation

PEEPi-intrinsic positive end expiratory pressure

Pdi-transdiaphragmatic pressure

Pgas-gastric pressure

Pmus-respiratory muscle pressure

Poes-oesophageal pressure

PS-pressure support asynchronous event

PSG-polysomnography

PSV- pressure support ventilation

PTP-pressure time product of the respiratory muscles

PVA-patient-ventilator asynchrony

PVAawake-patient-ventilator asynchrony occurring during wakefulness

PVAsleep-patient-ventilator asynchrony occurring during sleep

Pvent-ventilator pressure

QoL-quality of life

RIP-respiratory inductance plethysmography

Rrs-respiratory system resistance

r<sup>s</sup>-spearman correlation

RV-residual volume

SE-sleep efficiency

sEMGpara- surface second intercostal parasternal electromyogram

sEMGpara%max-surface parasternal electromyogram as a percentage of maximal parasternal inspiratory activity

SGRQ-St. George's respiratory questionnaire

SNIP-sniff nasal inspiratory pressure

SpO<sub>2</sub>-oxygen saturations detected by pulse oximetry

SRI-severe respiratory insufficiency questionnaire

TcCO<sub>2</sub>-transcutaneous carbon dioxide measurement

TLC- total lung capacity

TST- total sleep time

WASO-wake after sleep onset

V<sub>i</sub>- inspiratory flow

VAS-visual analogue scale

VC- vital capacity

Vt- tidal volume

## ABSTRACT

*Introduction:* Patient-ventilator asynchrony (PVA) can adversely affect the initiation of home mechanical ventilation (HMV). The aim was to quantify the prevalence of PVA during HMV and determine the relationships between PVA and adherence to therapy, respiratory muscle loading, nocturnal gas exchange, health-related quality of life measures and sleep quality.

*Method:* A pilot randomised control trial was conducted to compare a physiological led set-up of HMV, using neural respiratory drive to optimise ventilator set-up, to an expert led set-up. Type and frequency of PVA were measured by surface parasternal muscle electromyography, thoraco-abdominal plethysmography and mask pressure during initiation of HMV and 3 months post therapy. Severe PVA was defined as affecting  $\geq 10\%$  of breaths.

*Results:* 40 patients (25 male) were enrolled with an age of  $58 \pm 17$  years and a body mass index (BMI) of  $33 \pm 10 \text{ kg/m}^2$ . Underlying diagnoses were neuromuscular  $\pm$  chest wall disease (NMD-CWD,  $n=11$ ), obesity-related chronic respiratory failure (ORRF,  $n=13$ ) and chronic obstructive pulmonary disease (COPD,  $n=16$ ). Overall, PVA affected 25.6 (16.4-35.7)% breaths at initiation of HMV, with ineffective efforts as the predominant type of PVA affecting 10.9 (4.6-23.7)% breaths. No difference was observed in the frequency of PVA between physician led and physiological led set-up of HMV at initiation or 3 months (28.4 (17.4-37.6)% vs 25.6 (14.0-30.4)%;  $p=0.6$  and 22.4 (13.3-37.1)% vs 23.3 (15.2-41.5)%;  $p=0.7$ , respectively).

No correlations were observed between PVA and ventilator adherence ( $r_s=0.02, p=0.90$ ), nocturnal oxygen saturations ( $r_s=0.04, p=0.85$ ), nocturnal carbon dioxide levels ( $r_s=0.15, p=0.41$ ), respiratory muscle unloading ( $r_s=0.06, p=0.76$ ), patient perception of ventilator synchronisation ( $r_s=0.03, p=0.9$ ) at 3 months of HMV therapy.

10 patients (7 male) underwent polysomnography assessment of sleep quality. No further correlations were observed between PVA during sleep and sleep efficiency ( $r_s=-0.6, p=0.1$ ), wake after sleep onset ( $r_s=0.5, p=0.2$ ) or total sleep time ( $r_s=-0.4, p=0.3$ ) at 3 months of HMV therapy.

*Conclusion:* Severe PVA was identified in the majority of patients irrespective of pathophysiological disease. This was not associated with inappropriate delivery of effective ventilation. These data suggest that elimination of PVA may not be required to successfully set-up HMV.

# Chapter 1 Introduction

## 1.1 A History of Patient Ventilator Interaction

The first documented use of mechanical ventilation was as an aid to resuscitation in drowning victims in the early 1900s and patient ventilator asynchrony was therefore not considered. Negative pressure ventilation came into its own in the 1940s to 1950s with the Poliomyelitis epidemic and, interestingly, ventilatory support was considered sufficient if patients were unable to phonate during ventilation as the clinical conclusion was that inspiratory air flow into the thoracic cavity was adequate. Synchronisation with the ventilator was again of little concern as the ventilator was set at a fixed rate and the patient was not required to 'trigger' the ventilator but just patiently await the delivery of the mandatory breath.(1)

It was not until 1953 when Lassen *et al.* reported the benefit of manual positive pressure ventilation in the treatment of poliomyelitis that the concepts of patient ventilator synchrony and ventilator triggering were considered.(2) The first description of the need to design a ventilator to match the needs of a patient was described by Harrison in 1964.(3) He observed the benefits of patient triggered ventilation to reduce work of breathing and improve patient comfort.(3) Since then further research has detailed the importance of understanding the phases of ventilation produced by the ventilator and the impact of poor patient synchronisation with these phases, namely; the change from expiration to inspiration, the inspiratory phase, the change from inspiration to expiration and the expiration phase.(4-6) Since the use of the earliest ventilators, many studies have now been performed to compare different ventilator performance characteristics and modes of ventilation with their impact on patient ventilator synchronisation, work of breathing and patient comfort.(7-10) Overall these studies suggest that ventilator settings and performance may either enhance or adversely affect patient ventilation synchronisation but it remains unclear what the impact of poor patient-ventilator synchronisation on patient outcomes. The latter question will be addressed throughout this thesis.

## 1.2 Mechanisms of respiratory failure

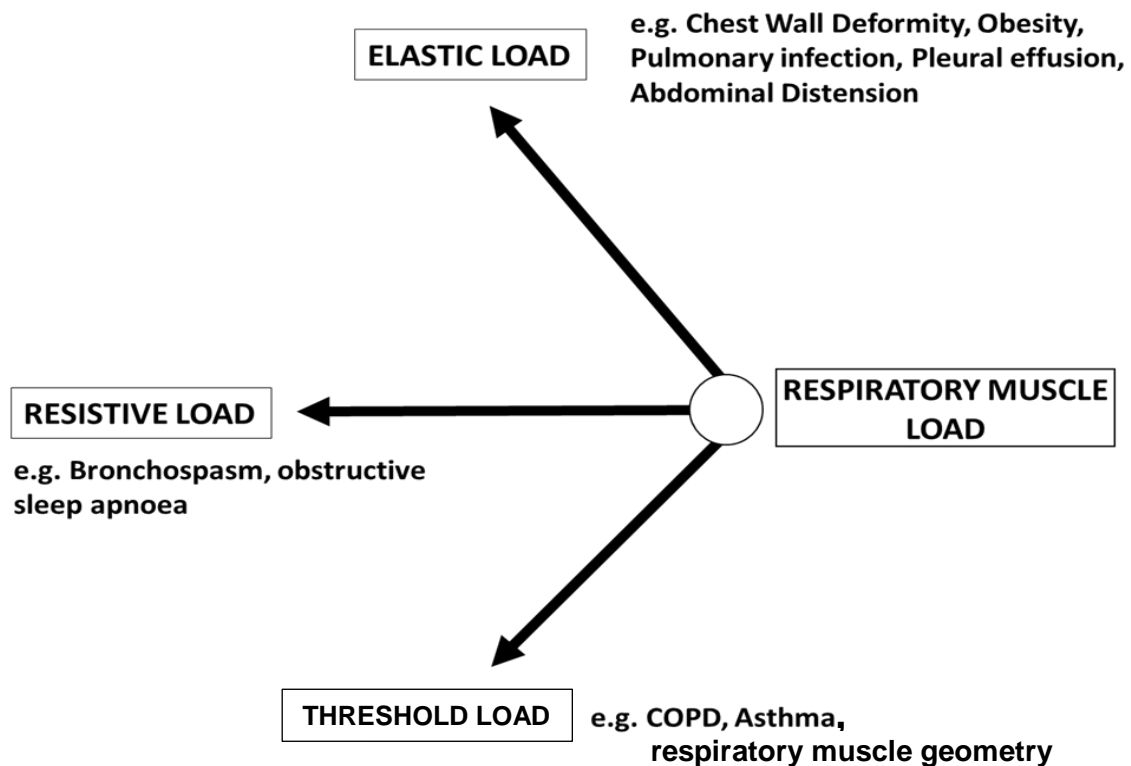
The respiratory system is made up of two main components; the respiratory muscle pump that facilitates airflow enabling ventilation and the lungs that support pulmonary gas exchange. The respiratory muscle pump itself is comprised of the inspiratory muscles, the diaphragm and chest wall intercostal muscles, and the expiratory muscles, principally the abdominal wall muscles. Inspiration is an active process in which contraction of the diaphragm forces the abdominal contents in an antero-caudal direction and contraction of the intercostal muscles lifts the rib margins up and outwards which allows the volume of the chest cavity to increase.(11) This, in turn, generates a negative sub-atmospheric pressure to form a pressure gradient that drives air from the atmosphere into the lungs.(12) At rest, expiration is a passive process with the elastic properties of the chest wall and lungs providing the recoil forces that allow the lung volume to return to the functional residual capacity. During spontaneous breathing the pressure generated by the respiratory muscles in inspiration must overcome the elastic and resistive forces that oppose inflation of the respiratory system. (13) This can be simply described by the equation of motion of the respiratory system:

$$P_{mus} = (R_{rs} \times V. + PEEP_i) + (E_{rs} \times V_t)$$

$P_{mus}$  is the pressure generated by the respiratory muscles,  $R_{rs}$  is respiratory system resistance,  $V.$  is inspiratory flow,  $PEEP_i$  is intrinsic positive end expiratory pressure,  $E_{rs}$  is respiratory system elastance and  $V_t$  is tidal volume..

Breathlessness, alveolar hypoventilation and hypercapnic respiratory failure result from an imbalance between the respiratory muscle load and capacity. In other words, the resistance and elastance of the airways, lung and chest wall plus the intrinsic positive end expiratory pressure associated with airflow limitation in chronic obstructive airways disease (respiratory muscle load) exceeds the strength and endurance of the respiratory muscle (respiratory muscle capacity).(14) This results in modification of the neural respiratory drive, which directly reflects the imbalance of the respiratory system. An increase in respiratory muscle load occurs in patients with chronic obstructive airways disease, obesity and chest wall deformity. (Figure 1). A reduction in respiratory muscle capacity occurs in patients with neuromuscular disease (e.g. motor neurone disease and muscular dystrophies) and chest wall deformity.

**Figure 1: Types of Respiratory Muscle Load**



Non-invasive ventilation (NIV) is used to positively assist this load-capacity imbalance by unloading the respiratory muscles and augmenting alveolar ventilation. This leads to a reduction in the patient's work of breathing and improved gas exchange with the aim of resolving the respiratory failure. (Figure 2).

During a pressure controlled mode of mechanical ventilation the patients respiratory muscle is completely off loaded i.e.  $P_{mus} = 0$ . In this situation the pressure applied to the respiratory system to facilitate inspiration is solely from the ventilator. The equation of motion of the respiratory system becomes (13):

$$P_{vent} = (R_{rs} \times V, + PEEP_i) + (E_{rs} \times V_t)$$

$P_{vent}$  is the pressure applied by the ventilator.

In assisted modes of ventilation such as pressure support ventilation both the patient and ventilator contribute to inspiratory pressure generation.(13)

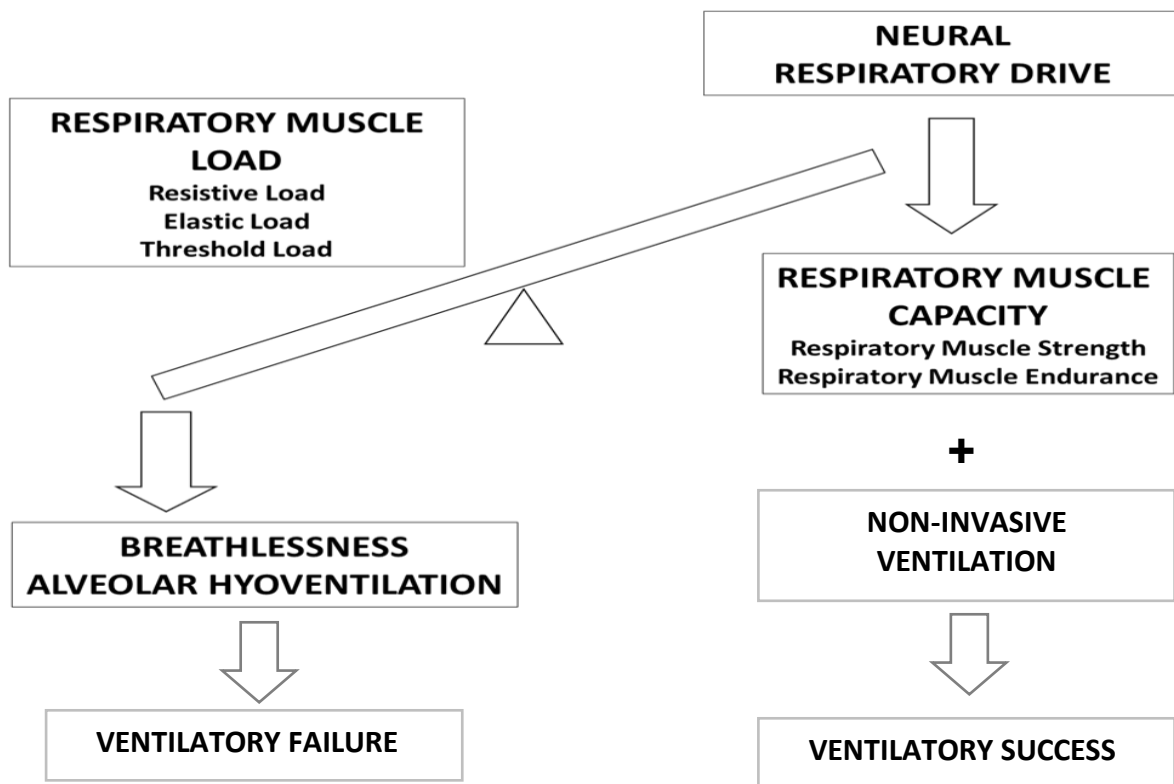
$$P_{vent} + P_{mus} = (R_{rs} \times V, + PEEP_i) + (E_{rs} \times V_t)$$

In addition to the manipulation of the load-capacity balance when using mechanical ventilation, multiple variables can be set on the ventilator to either decrease or if inappropriate increase a patient's work of breathing. The pressure support levels, inspiratory time, flow and volume settings of the ventilator dictated by the physician also have an effect on the patient's respiratory pattern and synchrony with the ventilator. Although increasing pressure support increases respiratory muscle unloading, very high levels of pressure support have been shown to both reduce neural respiratory drive to the respiratory muscles and increase intrinsic positive end expiratory pressure in obstructive airways disease adversely impacting on the triggering of the ventilator. (13, 15, 16)

A similar effect is seen with a fixed inspiratory time, increasing flow in this setting leads to increased tidal volume, activating stretch receptors which results in a negative feedback on the brainstem, reducing neural drive to the respiratory muscles.(11)

With high tidal volume or pressure support settings the ventilator will take longer to cycle into expiration and the ventilator inspiratory time may exceed the patients neural inspiratory time.(13) The expiratory time will be reduced and in obstructed pulmonary mechanics 'breath stacking' or hyperinflation may result.(13) Furthermore, high flow rates may induce tachypnoea through the Hering-Breuer reflex and have been shown to cause patient discomfort.(17, 18)

**Figure 2: The interplay of the load-capacity balance and its relationship with the ventilator to optimise ventilation in chronic respiratory failure**



### 1.3 Assessment of the patient in chronic respiratory failure

#### 1.3.1 Clinical Assessment

##### History

Clinical assessment should include a detailed focused history and examination. The main aim is to identify an underlying diagnosis and the severity of symptoms affecting the patient. The speed of onset of symptoms may help guide the timing of initiation of ventilation particularly in the neuromuscular disease patient group. In chronic ventilatory failure the onset may not be clear but clues can be gained from the history as to the course of events. Often patients will describe dyspnoea on exertion but if peripheral muscle weakness precedes respiratory muscle weakness the patient may not be able to exert themselves sufficiently to produce dyspnoea. Classical features of

diaphragm weakness are not always present in patients with generalised neuromuscular disease but may include dyspnoea on lying supine, on bending forward or on entering water where the depth reaches their waist.(19, 20) In all cases of respiratory muscle weakness it is reasonable to enquire about symptoms which might suggest generalised neuromuscular weakness, in particular about the patient's speech, swallowing and choking as well as weakness of the arms and legs. Weakness of the abdominal muscles may result in difficulty achieving an effective cough to clear debris from the airways. This leads to issues with sputum retention and greatly increases the risk of chest infection. Medication can exacerbate symptoms so common offenders such as corticosteroids and muscle relaxants should be identified and stopped where possible. Smoking history may help to support a diagnosis of chronic obstructive airways disease.

If hypercapnic respiratory failure is present patients may describe symptoms of nocturnal hypoventilation, such as daytime somnolence, reduced concentration and morning headaches that resolve typically within 30 minutes of waking.(21)

## **Examination**

Physical examination should be conducted to support the suspected diagnosis. In the case of obesity, kyphoscoliosis or chronic obstructive airway disease signs are usually self-evident.. Signs of underlying neuromuscular disease may be more subtle but examination may provide evidence of generalised muscle weakness in the form of muscle wasting and fasciculation or pseudohypertrophy. Scars of previous operations may indicate possible trauma to underlying neuromuscular structures. With severe diaphragm weakness abdominal paradox can be seen; where the diaphragm moves inwards on inspiration as opposed to outwards whilst the thorax expands. In more generalised weakness global loss of thoracic expansion on inspiration may be seen.

## **1.4 Clinical investigations**

### **1.4.1 Arterial blood gas (ABG) measurement**

ABG measurement is a useful first line investigation to detect acute, acute on chronic and chronic respiratory failure but the operator should be aware of its limitations. In particular, daytime PaCO<sub>2</sub> may be normal despite the presence of substantial inspiratory muscle weakness. However, it is

essential to confirm the presence of chronic respiratory failure and defining the severity. Chronic hypercapnic (type II) ventilatory failure is defined as a  $\text{PaO}_2$  of less than 8 kPa and a  $\text{PaCO}_2$  above 6kPa. Chronic ventilatory failure frequently presents insidiously and the patient may compensate for the increased acid load in the blood through renal retention of bicarbonate. Initial blood gases typically identify a picture of compensated chronic ventilatory failure where the pH remains within the normal range (7.35-7.45). In the event of rapid onset of neurological symptoms or in an acute deterioration of a chronic condition there is less time for renal buffering which takes in the region of a few days. ABG result interpretation will therefore describe decompensated chronic hypercapnic ventilatory failure with a  $\text{pH} < 7.35$  resulting directly from hypercapnia.

#### **1.4.2 Lung function tests**

Patients with respiratory neuromuscular weakness, chest wall disease and obesity present with features of a restrictive lung function pattern i.e. a low forced vital capacity (FVC) and an elevated forced expiratory volume in 1 second (FEV1) to FVC ratio, ( $\text{FEV1}/\text{FVC} > 80\%$ ). Whereas, patients with COPD present with airflow obstruction that is a low FEV1 to FVC ratio ( $\text{FEV1}/\text{FVC} < 70\%$ ). (22)

Total lung capacity (TLC) and vital capacity (VC) are diminished in restrictive lung disease, however, the functional residual capacity (FRC) is preserved and may, in fact, increase.(23) The residual volume (RV) is often increased especially if the expiratory muscles are involved. In obstructive lung disease, the TLC and RV are usually increased.

Although vital capacity (VC) has the advantage of simplicity, it is not very sensitive with significant muscle weakness being required (up to 50%) before an appreciable reduction is observed.(24) The VC is, of course, also reduced in restrictive chest wall conditions and indeed often in obstructive lung disease. A fall in VC on adopting the supine position is specific for respiratory muscle weakness and fall in VC of more than 20% indicates bilateral diaphragmatic weakness.(25) Importantly, falls in VC within the normal range may occur with moderate degrees of weakness or hemi diaphragm weakness which can be more difficult to detect.

### **1.4.3 Non-invasive and Invasive Respiratory Muscle tests**

Respiratory muscle strength tests are used to confirm respiratory muscle weakness in those with suspected underlying impairment. The commonly used non-invasive respiratory muscle tests can be easily performed with a handheld device and attached nasal bung or mouthpiece.

#### **Maximal inspiratory and expiratory pressures**

The maximal inspiratory pressure (MIP) is the maximal voluntary inspiratory pressure the patient can generate breathing in as measured the airway opening from FRC or RV. If performed from FRC encompasses only the strength of the respiratory muscles whereas from RV a component of elastic recoil is also included. Disadvantages are the volitional aspect of the test which means that it is partly dependent on patient effort.(24) Therefore while a high value ( $> 80$  cm H<sub>2</sub>O in men and  $> 70$  cm H<sub>2</sub>O in women) would confidently exclude inspiratory muscle weakness a low value is inconclusive.(24) The maximal expiratory pressure (MEP) is the maximal voluntary expiratory pressure the patient can generate breathing out; these are similarly measured from TLC or FRC. Challenges can be met in ensuring an adequate seal at the mouthpiece especially in patients with facial muscle weakness; a facemask may be preferred in this situation.

#### **Sniff nasal inspiratory pressure**

In order to negate issues of variability related to patient effort in performing maximal inspiratory manoeuvres, the maximal sniff nasal inspiratory pressures (SNIP) may be used as a more reliable outcome measure. The SNIP is initiated at FRC and is taken as the maximal short, sharp inspiratory sniff a patient can perform. It is usually measured through occlusion of one of the nasal passage with a nasal bung fitted with a small piece of tubing that connects to a handheld pressure transducer.(24, 26) Normal SNIP values would be  $>70$  cm H<sub>2</sub>O in males and  $>60$ cm H<sub>2</sub>O in females.(27) In view of the distance of the nose from the origin of the pressure generated at the active respiratory muscle pump, the pressure at the nose will be attenuated compared to the oesophageal or transdiaphragmatic pressures in patients such as those with airways disease.(24) To eliminate this problem it may also be necessary to measure transdiaphragmatic pressure during a sniff manoeuvre.

#### **1.4.4 Peak Cough Flow**

Peak cough flow (PCF) is another simple non-invasive measure of expiratory muscle function which can be useful in the absence of obstructive lung disease. It can be used as a marker of expiratory cough function and, consequently, the ability to clear respiratory secretions. A PCF value less than 160L/min is reported to be the cut-off value to predict an increased risk of chest sepsis (28).

#### **1.4.5 Invasive respiratory muscle tests**

Transdiaphragmatic pressure (Pdi) monitoring provides an assessment of diaphragmatic muscle strength and is derived from the gastric pressure (Pgas) minus the oesophageal pressure (Poes).(29) Pdi is assessed in combination with maximal inspiratory manoeuvres described above as to better identify inspiratory muscle weakness. Pdi monitoring requires the '*per nasal*' passage of a catheter with an oesophageal and gastric balloon attached to a pressure transducer to record the Pgas and Poes. EMG pair electrodes can also be attached to the catheter to directly measure crural diaphragm electromyography as a marker of neural respiratory drive.(30)

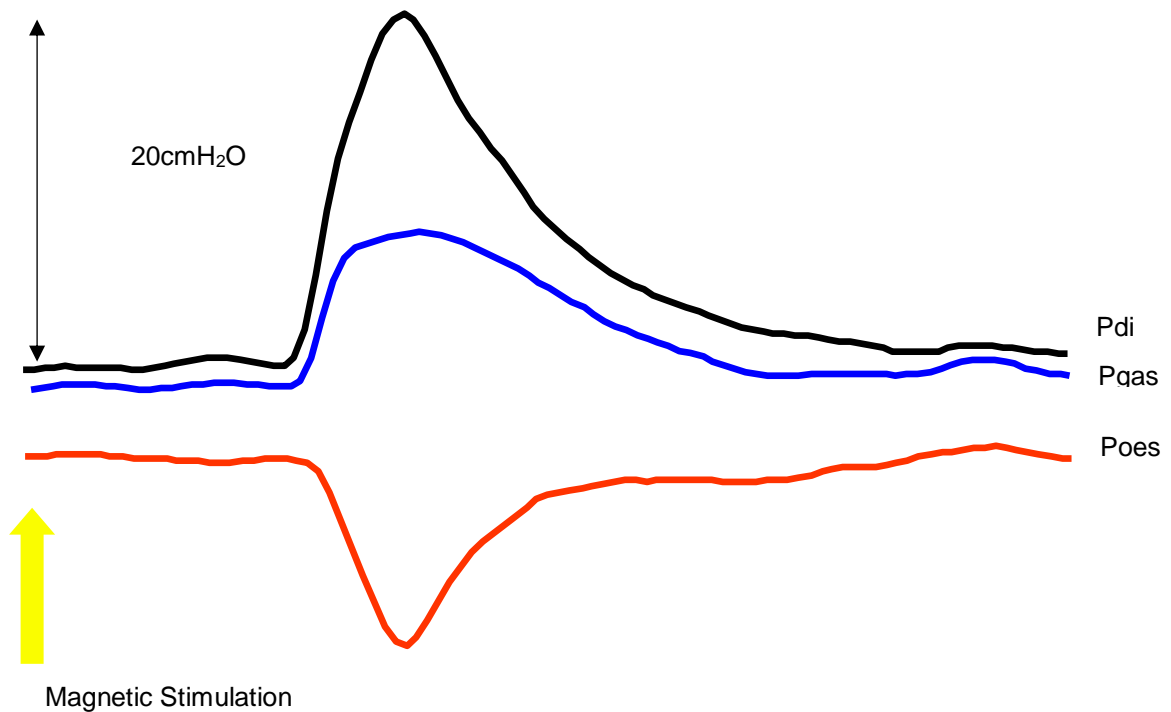
The phrenic nerve (originating from cervical nerve roots 3, 4 and 5) is selective in supplying the diaphragm only. To identify diaphragm muscle weakness the phrenic nerve can be activated by both an electric and magnetic stimulus, which is known as a 'twitch'.(31) The measurement of Pdi following supramaximal phrenic nerve stimulation currently provides the gold standard measurement for demonstrating unilateral or bilateral diaphragm weakness.(24) Although this has the advantage of being a non-volitional test, measuring Pdi is an invasive test and maybe poorly tolerated by patients and, on occasions, it is not possible in those patients with bulbar weakness.

**Figure 3: Equipment required to measure twitch transdiaphragmatic pressure, diaphragm and simultaneous parasternal electromyography**



*Written permission kindly received from the patient for this photograph*

**Figure 4: An example of a Twitch transdiaphragmatic pressure signal**



*Abbreviations: Pdi—transdiaphragmatic pressure, Pgas-gastric pressure, Poes-oesophageal pressure*

#### **1.4.6 Imaging**

The chest radiograph is most helpful in identifying other reversible causes of respiratory failure. It may also assist a diagnosis of COPD where evidence of hyperinflation may be seen. However, an elevated hemi diaphragm as seen on plain chest radiography is often considered to indicate diaphragmatic paralysis but this in fact is only confirmed by diaphragmatic testing in approximately 24% of cases.(32)

Computerised tomographic (CT) scanning may have particular value in the assessment of pleural causes of restriction. It is seldom helpful in obesity except to exclude thrombo-embolic disease although parenchymal lung disease may be an unexpected coincidental finding. The chest radiograph of patients with scoliosis is often difficult to interpret and here CT scans may reveal new abnormalities when there is a clinical index of suspicion..

#### **1.4.7 Overnight physiological monitoring**

Overnight oximetry and capnography is an essential part of the assessment to facilitate the early detection of nocturnal hypoventilation. It is recommended in anyone with neuromuscular disease describing symptoms of sleep disordered breathing, such as daytime somnolence, early morning headaches, orthopnoea and a decline in cognitive functioning. Some groups advocate the use of polysomnography to confirm arousals during apnoeas and hypopnoeas and therefore quantify the extent of sleep disturbance.(33, 34) This is not routinely used in UK practice. In our unit, we typically titrate ventilatory support to the degree of hypercapnia identified irrespective of the sleep stage of the patient. Surrogates for sleep fragmentation events can be crudely identified from transcutaneous capnography and oximetry alone.(35) Respiratory inductance polygraphy (RIP) measures abdominal and thoracic excursion and may be used to differentiate obstructive and central apnoeas.

### **1.5 The role of domiciliary non-invasive ventilation in chronic respiratory failure**

Mechanical ventilation has progressed over the last century from negative pressure ventilation to positive pressure ventilation and the development of non-invasive interfaces facilitating its use in a

domiciliary setting. Initial demand for non-invasive respiratory support was driven by the increase of respiratory failure accompanying the poliomyelitis epidemics of the 1930-1940s. Non-invasive ventilation (NIV) has become one of most significant advances in treating hypercapnic respiratory failure over the last 20 years and with its substantial benefits its use has increased by 400% over the last 10 years for acute exacerbations of COPD alone.(36) Recent demand is changing to include patients with chronic obstructive pulmonary disease and obesity hypoventilation syndrome with an emerging obesity epidemic.(1) Although all these patients may present with a similar degree of respiratory failure, the aetiology differs widely and poses very different pulmonary mechanical challenges on the interaction between the patient and ventilator.

### **1.5.1 Neuromuscular Disease (NMD)**

In patients with NMD, there is limited pressure generating capacity of the respiratory pump mainly as consequence of intrinsic muscle weakness. There is substantial reserve in the respiratory muscle pump, such that inspiratory muscle strength must fall to one third of normal before the onset of respiratory failure occurs.(37) On occasions, there can be relative preservation of vital capacity. However, in the context of a significant respiratory muscle load or poor orientation of the inspiratory muscles (e.g. kyphoscoliosis), dyspnoea and alveolar hypoventilation can develop. An increased load applied to the respiratory system, such as an episode of pneumonia, or if the neural respiratory drive is modified with drugs (such as benzodiazepines, opiates and other anaesthetic agents during routine anaesthesia), may precipitate respiratory failure to be observed at an earlier stage. Patients with respiratory muscle weakness, in particular diaphragm weakness and paralysis, often present with signs of hypoventilation during rapid eye movement (REM) sleep as the first sign of declining respiratory function due to a reduction in neural respiratory drive to the respiratory muscles during REM sleep.(37)

Early studies identified that a majority of patients with progressive NMD such as Motor Neurone Disease and Duchenne Muscular Dystrophy died from respiratory failure, suggesting a role for long term non-invasive ventilatory support.(38) Studies have since shown a significant improvement in gas exchange following 3 months use of non-invasive ventilation. The mechanism of action has been associated with an improved hypercapnic ventilatory response seen as early as at 5 days with further improvement at 3 months.(39) No changes in pulmonary mechanics defined by lung volume and

compliance measurements or respiratory muscle strength tests were seen.(39) Data from previous studies have suggested that long term domiciliary non-invasive ventilation improved survival and quality of life for selected patients with NMD. A randomised controlled trial (RCT) of NIV treatment compared to standard care, based on 41 patients with motor neurone disease, identified an overall survival benefit of 48 days and improved quality of life scores following NIV use but no improvement in survival for those with severe bulbar dysfunction.(40) These trials have been used to support the use of domiciliary NIV in NMD patients. However, the optimum timing of NIV initiation remains unclear. Common clinical practice is to start NIV when the patient has symptoms of nocturnal hypoventilation, such as early morning headaches or increased daytime somnolence, or if there is profound respiratory muscle weakness with signs of orthopnoea or daytime hypercapnia. An RCT comparing initiation of NIV pre-respiratory failure to standard care in 70 Duchenne Muscular Dystrophy patients did not show any protective effect of prophylactic NIV in delaying the onset of respiratory failure and a higher mortality in the early ventilated group.(41) However, other differences in the clinical management of the two groups call the findings of this study into question. Often in chronic neuromuscular disease, respiratory muscle weakness requiring ventilatory support signifies a move towards considering end of life care. This can be a challenging time for both patients and relatives, it is crucial that appropriate support and discussions are had in advance to anticipate concerns and tailor respiratory care to the patient. Patients may need to adapt to the use of the ventilator and the timing initiation must be carefully planned so that the benefits of NIV outweigh its inconvenience. (42)

Most of the studies of NMD have also included patients with chest wall disease (CWD) and shown a survival benefit of using NIV compared to home oxygen therapy.(43) The mechanism of action of improved gas exchange is again thought to be due to an improved hypercapnic ventilatory response.(39)

Primarily due to intrinsic muscle weakness in NMD or poor orientation of respiratory muscles in CWD, these patients have difficulties in optimising the respiratory pump function to generate negative pressure within the chest and so induce air flow into the lungs. Most domiciliary non-invasive ventilators are triggered by changes in pressure or flow.(44) Patients with NMD or CWD are unable to achieve this reliably and so will commonly experience triggering difficulties with the ventilator.

Facial muscle weakness can make interfaces prone to leak which may also interfere with ventilator triggering and cycling to expiration. Persistent leak beyond leak compensation capacity of the ventilator is interpreted as patient inspiratory demand.

### **1.5.2 Chronic Obstructive Pulmonary Disease (COPD)**

Patients with COPD exhibit expiratory airflow limitation as a consequence of airways resistance and reduced lung compliance.(45) A complication is incomplete lung emptying, lung hyperinflation and a positive end expiratory pressure.(46) The positive end expiratory pressure acts as a threshold load that must be overcome to enable airflow during inspiration. In addition to this, the respiratory muscle pump capacity is reduced by the mechanical disadvantage of diaphragm muscle shortening that accompanies hyperinflation.(47) Inflammation causes both airway and parenchymal destruction leading to increased dead space ventilation, ventilation perfusion mismatching, and inadequate ventilation.(47)

The evidence for using NIV to treat acute exacerbations of COPD is well established.(48) However, the evidence to support long term domiciliary ventilation is less clear. Long term oxygen therapy, when used for more than 15 hours a day, has shown a survival benefit in patients with severe COPD but does not control nocturnal hypoventilation.(49) As with the neuromuscular patients, the use of nocturnal NIV to support patients who are symptomatic from nocturnal hypoventilation would seem appropriate. Previously, there was little evidence to suggest that non-invasive ventilation has a significant survival benefit or reduction in exacerbation rate over long term oxygen therapy alone.(50-52) These studies have been criticised for using small numbers of patients that have had insufficient acclimatisation to NIV before starting the study and for using insufficient pressure support to control hypercapnia.(53) A study by Windisch *et al.* in 2009 suggested that using higher pressure support (mean IPAP of 28cmH<sub>2</sub>O, mean EPAP 4cmH<sub>2</sub>O) improved daytime hypercapnia, lung function and haemocrit, plus perhaps reduced mortality and the frequency of exacerbations compared to previous data.(54) Most recently, Murphy *et al.* have demonstrated a 3 month improvement in admission free survival over a 12 month period following an exacerbation with hypercapnic respiratory failure with the use of HMV. Patients recruited in this study had persistent hypercapnia (PaCO<sub>2</sub> >7kPa, >53mmHg) 2-4 weeks post the resolution of respiratory acidaemia following an exacerbation of COPD.(55) This

would suggest that identifying and targeting the subset of patients with COPD that have chronic respiratory failure are most likely to benefit from HMV. Patients that are unable to tolerate long term oxygen therapy without becoming significantly hypercapnic may also find some improvement. COPD patients with frequent admissions to hospital in hypercapnic respiratory failure may be another subgroup who could be considered for home non-invasive ventilation. These principles are used to provide non-invasive ventilation for COPD patients in our respiratory high dependency unit.

The mechanism of ventilatory improvement with NIV in COPD patients was studied by Nickol *et al.* (56) This demonstrated an improvement in the patients ventilatory response to breathing carbon dioxide from just 5 days use of NIV. Patients were followed for a total of 3 months. Hyperinflation reduced, suggesting improvements in pulmonary mechanics, but no change in respiratory muscle strength was observed.

Due to altered pulmonary mechanics, COPD patients can develop a number of difficulties in coordinating with the ventilator. Frequently, the patient can experience inspiratory efforts that are not successful in triggering the ventilator. Unlike the neuromuscular patients, this is thought to be related to positive end expiratory pressure, which must be overcome to generate a negative pressure change in the thorax and facilitate inspiratory flow to trigger the ventilator.(13, 15) The combination of breaths that are unable to trigger the ventilator and the added load of breaths that do trigger the ventilator markedly increases the patient's work of breathing and may lead to an underestimation of the respiratory rate. Increasing the trigger sensitivity may not assist in improving triggering of the ventilator. Instead, prior studies have suggested that adding an external end expiratory pressure (EPAP) can reduce the number of ineffective breaths and the work of breathing.(57, 58) Another approach is to reduce the pressure support applied to the patient. This has been shown to reduce ineffective patient breaths by limiting the delivery of excessive tidal volume, reducing dynamic lung hyperinflation and improving positive end expiratory pressure in obstructed patients.(8, 18)

COPD patients may also experience poor synchrony when the ventilator changes from inspiration to expiration by a reduction in the inspiratory pressure applied. This is known as 'ventilator cycling'. The ventilator is usually triggered to change into the expiratory phase by a reduction in inspiratory flow commonly when inspiratory flow has decreased to 25 percent of the peak flow rate achieved during the breath.(13) In obstructed airways, lower peak flow rates are achieved and the flow rates take

much longer to reach 25 percent of the maximal flow rate. A patient with severe COPD may take a second longer to reach 25 percent of maximal flow rate compared to a subject without obstructed lung disease.(13) If the ventilator continues to provide inspiratory support which the patient no longer requires, this will reduce the time available for expiration, reduce lung emptying capacity and may therefore lead to worsening dynamic hyperinflation and positive end expiratory pressure. As described above, this may consequently impair triggering of subsequent breaths and increase the work of breathing.(59)

### **1.5.3 Obesity Hypoventilation Syndrome (OHS)**

Obesity hypoventilation syndrome is defined as a combination of Obesity (BMI >30 kg/m<sup>2</sup>), daytime hypercapnia (PaCO<sub>2</sub> > 6kPa) and sleep disordered breathing.(60) It is hypothesised that breathlessness and alveolar hypoventilation in obese patients results from an imbalance between the respiratory muscle load, capacity and neural respiratory drive, although the exact pathophysiological details are yet to be determined. Fat distribution has a significant effect on pulmonary mechanics with central obesity placing the largest load on the respiratory system. Respiratory muscle capacity, albeit estimated using volitional MIP and MEP measurements, was found to be reduced in hypercapnic

obese patients compared with eucapnic obese patients.(61) However, direct measurement of diaphragm strength, using  $P_{di_{max}}$ , demonstrated no difference between eucapnic and hypercapnic obese patients indicating that diaphragm weakness does not contribute to the development of ventilatory failure in obese patients.(62) In contrast, there is a difference in respiratory muscle load between hypercapnic obese patients and eucapnic obese subjects with greater upper airways resistance in both sitting and supine position and reduced respiratory system compliance.(63, 64) This increasing load on the respiratory muscles results in a reduction in lung volumes, with a reduction in  $FEV_1$  and FVC and an elevated  $FEV_1/FVC$  ratio confirming a restrictive defect.(64) In addition, TLC, expiratory reserve volume (ERV) and FRC are all reduced. Interestingly, these reductions are more marked in obese patients with hypercapnic respiratory failure compared with eucapnic obese subjects with a matched BMI.(64) This indicates that in addition to absolute fat load the distribution of the fat is important in determining the severity of lung restriction. The reduction in lung and chest wall compliance results from the obese patient breathing at a lower lung volumes..(65) Breathing at a lower lung volume also results in closure of the small airways during early expiration causing expiratory airflow limitation and development of intrinsic positive end-expiratory pressure (PEEPi).(64) This phenomenon is exacerbated by an obese patient adopting a supine position, such as occurs during sleep.(66)

Work by Piper *et al.* has demonstrated that non-invasive ventilation in OHS does improve physiological parameters such as gas exchange, sleep quality, daytime somnolence and health related quality of life measures.(67) Nowbar *et al.* have suggested a survival benefit with NIV use but there have not been any studies to compare treatment against standard care.(68) A prospective RCT comparing NIV with CPAP therapy did not suggest any additional benefit of NIV however the patients recruited to this study did not have severe nocturnal hypoventilation.(67) Ventilatory benefit of NIV in OHS is again thought to be mediated by an improved hypercapnic ventilatory response.(69)

Very few studies have been performed looking at patient ventilator synchrony in obese patients. Potential problems related to an elevated positive end expiratory pressure may be predicted to manifest as difficulties in triggering the ventilator similarly to that seen in COPD. Upper airways obstruction that often accompanies hypoventilation in these patients may also impact on ventilator triggering making it difficult to generate flow against this obstruction. A study by Guo *et al.* identified

poor synchronisation with the ventilator affecting more than half of the 20 obese patients studied predominantly in sleep stages 1 and 2.(70) The authors also demonstrated that the asynchronous events occurring in sleep stages 1 and 2 were more likely to result in arousals.(70)

## **1.6 Non-invasive ventilation (NIV) failure**

Despite the benefits of NIV, a significant number of patients still fail to comply with NIV. NIV failure rates for acute exacerbations of COPD, pulmonary oedema and all cause acute respiratory failure are quoted between 5 and 38%.(71, 72) Late NIV failure (more than 48 hours post initiation) confers a much higher mortality risk and recent data published by Chandra *et al*, based on 7.5 million COPD admissions in the United States of America, suggests that this group of patients is increasing.(36) A recent BTS audit (2013) into adult non-invasive ventilation in the United Kingdom identified that 'general intolerance' was the cause of a third of patients failing acute NIV.(73)

Similarly to acute NIV, a proportion of patients fail to adhere to domiciliary non-invasive ventilation. Data from our own high dependency respiratory unit has quoted an average failure rate of 38% at one year. The failure rates vary across disease groups with 13.8% of COPD patients, 22.8% of NMD and chest wall disease (CWD) patients and 41.6% OHS patients failing long term NIV at one year.(74) After death, the commonest cause for NIV failure was poor tolerance of ventilation.

Potential causes of NIV failure have been suggested as poor-patient selection, progression of the underlying disease process, poor patient tolerance of interfaces and the ventilator strategy used. Whilst some factors are not modifiable such as the severity of pathology affecting the patient, the appropriate set up of the ventilator is physician dependent and could be manipulated to improve patient-ventilator synchrony. Improved synchrony may lead to complete respiratory muscle unloading, improved patient comfort and therefore better tolerance and adherence to ventilation. To date, a direct relationship between poor patient ventilator synchrony and NIV failure has not been demonstrated. However, poor patient-ventilator synchrony has adversely affected gas exchange, respiratory muscle unloading, sleep quality and patient comfort. (18, 75, 76)

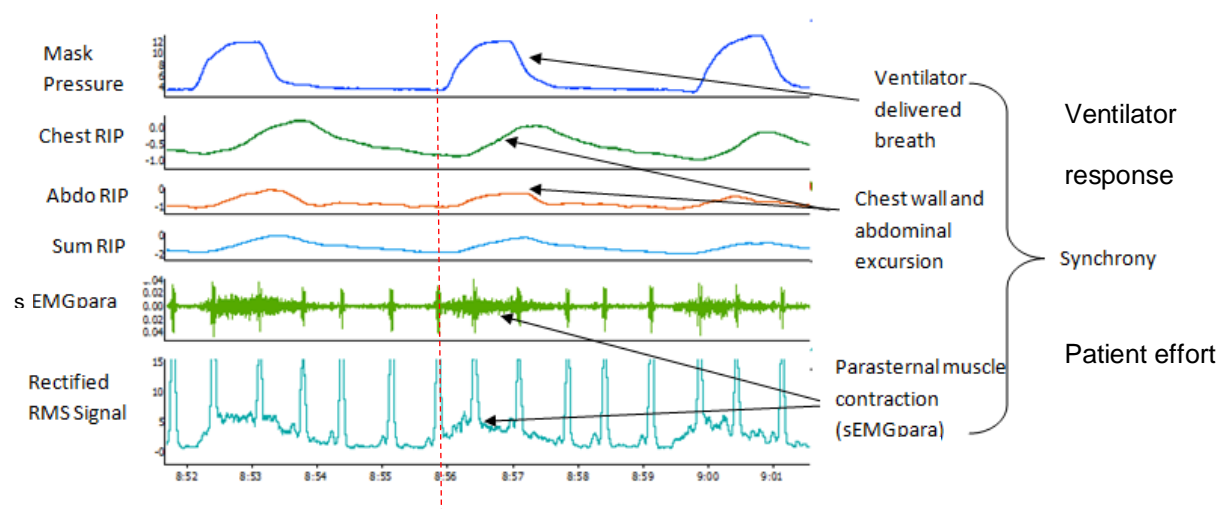
## 1.7 Patient-Ventilator Interaction in Mechanical Ventilation

### 1.7.1 Defining patient-ventilator synchrony

Patient ventilator synchrony describes the co-ordination between the patient's respiratory effort and the mechanical breaths delivered by the ventilator. The ideal situation would be for both the patient's neural inspiratory phase to match the ventilator inspiratory time (Ti) and the patient's expiratory phase to match the ventilators cycling into expiration.

In other words: **Neural<sub>inspiration</sub> = Ventilator<sub>inspiration</sub>** and **Neural<sub>expiration</sub> = Ventilator<sub>expiration</sub>**. This is often referred to a neuroventilatory coupling. .

**Figure 5: An example of adequate patient ventilator synchrony**



*Abbreviations:* Chest RIP- chest wall respiratory inductance plethysmography, Abdo RIP- abdominal wall respiratory inductance plethysmography, Sum RIP- Sum of both the chest wall and abdominal inductance plethysmography bands, sEMGpara- second intercostal parasternal electromyography signal, Rectified RMS Signal- rectified root mean square of the parasternal electromyography signal.

When patient and ventilator matching is incomplete, 'patient-ventilator asynchrony' occurs. Patient-ventilator asynchrony may affect all phases of the inspiratory and expiratory breathing cycle.

### 1.7.2 Difficulties in assessing the prevalence of patient-ventilator asynchrony

Previous work has assessed the prevalence of patient-ventilator asynchrony (PVA) predominantly in association with invasive ventilation in the intensive care unit. When describing the prevalence of asynchrony the reader must be cognisant of the observation period. As asynchrony is an intermittent phenomenon, very short observation periods may fail to detect and capture the quantity and type of PVA that is actually present. As patient factors, such as disease progression or improvement, may change on a daily basis different amounts of asynchrony may be seen in the first 24 hours compared to that seen a few weeks post initiation of ventilation. One would also predict that differences in the asynchrony levels may relate to the changes in neural drive and breathing pattern between when the patient is awake or asleep. The current literature has reported PVA over a range of time from 1 minute to 120 minutes, which, although useful, provides only a PVA snapshot. (Tables 1-3).

The asynchrony detection method may also affect the reported prevalence of events. The current gold standard detection method is the measurement of the oesophageal pressure (a negative pressure indicating the start of inspiratory flow) and a measure of the electrical activity of the respiratory muscles (indicating the precise start of neural inspiratory and expiratory time). This is commonly measured by *per nasal* placement of a pressure monitoring catheter with a multiple array of electrodes attached to measure the crural diaphragm muscle electromyogram (EMGdi). The oesophageal and gastric pressures (Poes and Pgas) are measured via balloons mounted on the same catheter and connected to 2 pressure transducers as described in Section 1.4.5.

Using simple markers of pressure, flow or ventilator waveforms without respiratory muscle electromyography may underestimate or overestimate the number of asynchronous events. In patients with obstructive pulmonary mechanics and positive end expiratory pressure or neuromuscular disease, the respiratory muscle contraction may be insufficient to result in a detectable change in pressure or flow and so the patient's respiratory effort would be under reported. Conversely, in the presence of extrinsic factors such as airway secretions, interface leak or cardiac oscillations, interruptions in pressure or flow signals may falsely be attributed to patient effort. This would lead to an overestimation of certain types of PVA. (Tables 1-3).

### **1.7.3 Difficulties in reporting the prevalence of patient-ventilator asynchrony**

To date, studies reporting asynchrony data lack a uniform approach describing PVA as the percentage of patients with asynchrony or the percentage of breaths that are defined as asynchronous. Others have described PVA as the percentage of total asynchronous breaths only and as the number of asynchronous events occurring per minute or per minute per individual patient. This ambiguity has made it difficult to compare the prevalence of asynchronous events between different studies and different disease groups. In order to improve on these discrepancies, Thille *et al.* developed an asynchrony index.<sup>(77)</sup> This ratio was expressed as a percent defined as the number of asynchronous events divided by the total respiratory rate. The total respiratory rate was calculated as the sum of all the ventilator delivered breaths (triggered and non-triggered) plus the wasted inspiratory efforts demanded by the patient without triggering the ventilator (ineffective efforts). Work by Vitacca *et al.* based solely on ineffective efforts (a single type of patient ventilator asynchrony) evaluated the effect of different ventilator pressure support settings on PVA.<sup>(18)</sup> When pressure support was removed and a PEEP (positive end expiratory pressure) of 5 cmH<sub>2</sub>O was applied to the patient, the mean plus the standard deviation of the percentage of ineffective efforts did not exceed 10% of breaths per minute. Thille *et al.* defined an asynchrony level with an asynchrony index less than 10% of breaths affected as acceptable. Subsequent studies have focused on this cut off level of 10% of all breaths (both delivered and requested) to investigate consequent clinical outcome measures.<sup>(77, 78)</sup>

### **1.7.4 Critique of the current asynchrony index**

Using a 10% cut off level for the asynchrony index as a measure to describe the prevalence of PVA may not be translatable across all types of asynchrony because it was based on a single type of asynchrony (ineffective efforts). The asynchrony index reported by Vitacca *et al.* was developed based on 36 patients receiving invasive ventilation in the intensive care setting. It is not yet clear if using a 10% cut off for this index provides any useful clinical information in patients receiving non-invasive ventilation. Furthermore, as the asynchrony index is a categorical rather than a continuous variable, the current 10% cut off does not provide the clinician with an appreciation of the magnitude of the problem as the asynchrony index could range from 11% to 100% for which the clinical implications may be wholly different. The current asynchrony index was based on data measured over a one minute period, which may not provide an accurate reflection of the PVA occurring over the many hours that mechanical ventilation is used.

Despite these criticisms, in the invasive ventilation setting an asynchrony index greater than 10% has been associated with important patient outcomes such as increased duration of mechanical ventilation, reduced ventilator free survival, increased hospital length of stay and a reduced likelihood of discharge home.(78)

### 1.7.5 Prevalence of patient-ventilator asynchrony in invasive ventilation

Studies of PVA during the first 24 hours of invasive ventilation in the intensive care setting demonstrated asynchronous events affecting 27% to 42% of patients. (Table 1). In studies of patients on invasive mechanical ventilation for more than 24 hours, PVA were identified over a wider range affecting 11% to 72% of patients. (Table 2).

**Table 1: A summary of the amounts of asynchrony reported during invasive ventilation for acute respiratory failure (<24hrs) in pressure support mode**

Study (Year)	Number of patients analysed	Length of analysis (mins)	Method of detection of asynchrony	Prevalence of asynchrony described
Jubran <i>et al.</i> (1995)	12	10	Flow, Paw, Pes	Delayed cycling 5/12 patients (42%)
Younes <i>et al.</i> (2007)	21	60	Transdiaphragmatic pressure, Flow, Paw	Severe Ineffective efforts (>10% breaths) affected 7/20 patients (35%)
Mulqueeny <i>et al.</i> (2009)	23	10-20	Flow, Paw, transdiaphragmatic pressure	10% breaths were ineffective efforts (combined data with non-invasive ventilation)
De Wit <i>et al.</i> (2009)	60	10	Ventilator pressure and flow waveforms	27% patients AI ineffective efforts > 10% breaths

*Abbreviations:* Paw-airway pressure, Pes-oesophageal pressure, AI-asynchrony index.

**Table 2: A summary of the amounts of asynchrony reported during invasive ventilation for respiratory failure (>24hrs) in pressure support mode**

Study	Number of patients	Length of time on ventilation	Length of analysis (mins)	Method of asynchrony detection	Prevalence of asynchrony described
Fabry et al. (1995)	11	Mean 3.8 days (range 1-10)	5 (taken at intervals over 25-150 hrs)	Paw, Flow and Pes	Ineffective efforts mean range 0-40% of all ventilator delivered breaths.
Nava et al. (1997) erj	24	>48hrs	5	Flow and transdiaphragmatic pressure	Ineffective efforts affected 54.2% patients.
Chao et al. (1997)	174	Range 3 to 371 days	2	Pes, Paw and Flow, Clinical observation of respiratory muscle effort	10.9% patients demonstrated ineffective efforts
Leung et al. (1997)	11	n/a (9 via tracheostomy)	1	Paw, Flow, Pes	Ineffective efforts 2-6/ per minute (higher with higher PS, 26% of breaths)
Vitacca et al. (2004)	36	Range 22 to 57 days	5	Ventilator flow and pressure waveforms	Ineffective efforts observed in 72% patients (affecting a mean approx 10% breaths/minute)
Thille et al. (2006)	62	>24hrs	30	Paw and Flow	24% patients AI > 10%
Mulqueeny et al. (2007)	10	n/a –advanced stage of weaning	30	Transdiaphragmatic pressure	30% patients AI> 10% Ineffective efforts 15.1% breaths Double triggering 1.2 % breaths
Colombo et al. (2008)	14	Range 2 to 19 days	60	Paw, Flow and Diaphragmatic EMG	36% patients had and AI> 10%.
Piquilloud et al. (2011)	22	3days +/- 2	40	Paw, Flow and Diaphragmatic EMG	60% patients had an AI > 10 % . (Equivalent to approx 3 /min)

Gutierrez <i>et al.</i> (2011)	110	Range 1 to 5.8 days	120	Flow and Paw	50.9% patients AI> 10%. Ineffective efforts 70.2% of asynchrony. Double triggering 29.8% of asynchrony.
-----------------------------------	-----	------------------------	-----	--------------	---

*Abbreviations:* Paw-airway pressure, Pes-oesophageal pressure, AI-asynchrony index, EMG-electromyogram.

### 1.7.6 Prevalence of patient-ventilator asynchrony in non-invasive ventilation

Non-invasive ventilation includes the added complications of an open circuit with an interface which is prone to air leak interfering with the synchrony of the patient and ventilator. In addition, the patients themselves are also less likely to be sedated or paralysed which will impact on the patient's neural ventilatory drive and respiratory patterns. Despite this, perhaps related to improvements in leak compensation mechanisms of the non-invasive ventilators, asynchronous events were identified in 0% to 43% of patients. (Table 3).

**Table 3: A summary of the amounts of asynchrony reported during non-invasive ventilation in pressure support mode**

Study (Year)	Number of patients analysed (n)	Length of analysis (mins)	Method of detection of asynchrony	Prevalence of asynchrony described
Fanfulla <i>et al.</i> (2007)	48	5	Paw, Flow, respiratory inductance plethysmography	Ineffective efforts affected approx. 4% breaths.
Moerer <i>et al.</i> (2008)	7 (healthy)	2	Flow, Paw, Pes	Mean range 5 to 55% of the total breath duration. (variable PS and RR applied)

Vignaux <i>et al.</i> (2009)	60	30	Paw, Flow and surface diaphragm EMG	43% patients AI > 10% -Delayed cycling 23% patients -Double triggering 15% patients - Ineffective efforts 13% patients - Auto-triggering 13% patients -Premature cycling 12% patients
Mulqueeny <i>et al.</i> (2009)	23	10-20	Flow, Paw, transdiaphragmatic pressure	10% breaths were ineffective efforts (combined data with invasive ventilation)
Vignaux <i>et al.</i> (2010)	65	30	Paw, Flow, surface diaphragm EMG	38% patients AI >10% ICU ventilator with NIV algorithm (commonest asynchrony premature cycling) 46% patients AI > 10% ICU ventilator without NIV algorithm (commonest asynchrony premature cycling)
Carteaux <i>et al.</i> (2012)	15	20	Flow, Paw, neck surface EMG and surface diaphragm EMG	0% patients had AI >10% using domiciliary NIV (no asynchrony seen) 13% patients had AI >10% using ICU ventilator with NIV algorithm (commonest asynchrony auto-triggering) 27% patients had AI >10% using ICU ventilator without NIV algorithm (commonest asynchrony auto triggering)

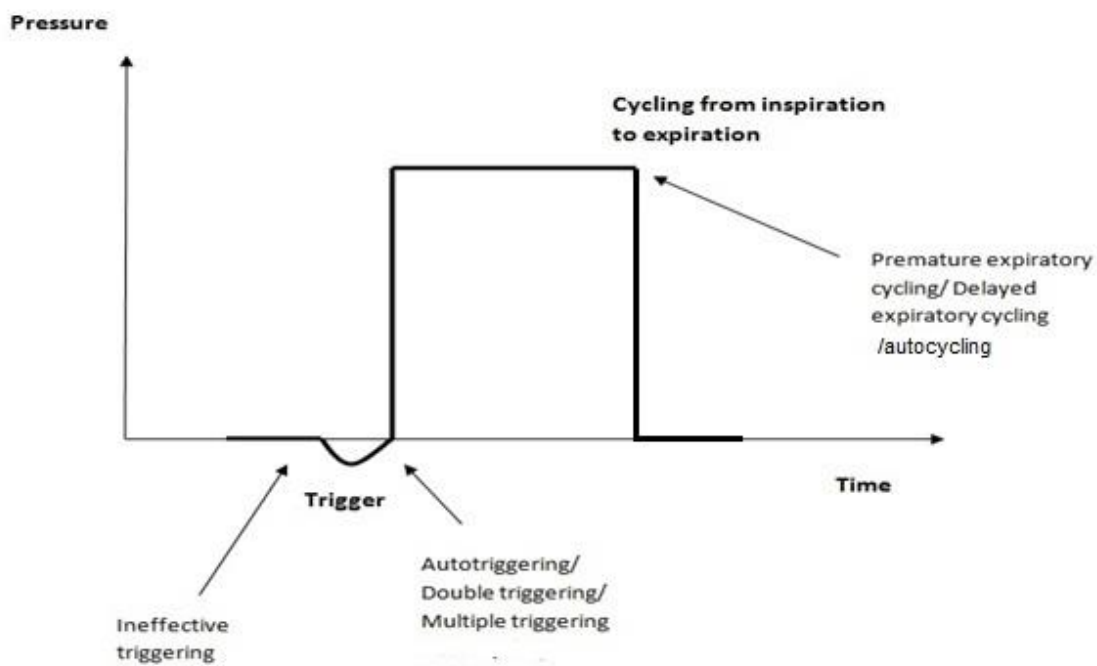
*Abbreviations:* Paw-airway pressure, Pes-oesophageal pressure, AI-asynchrony index, EMG-electromyogram, NIV- non-invasive ventilation, PS-pressure support, RR-respiratory rate.

## 1.8 Types of patient-ventilator asynchrony

PVA can occur at any point of the breathing cycle and is best explained by examining the ventilator pressure waveform. (Figure 7). A patient can have difficulties in triggering the ventilator '**ineffective effort**' or conversely the ventilator may trigger automatically without any patient demand '**autotriggering**' (a single event). These events may occur twice in quick succession '**double triggering**', or in multiples '**autocycling**'. Following successful triggering of the ventilator a patient may have difficulties with the ventilator cycling appropriately into expiration, cycling may be too early whilst the patient is still in active inspiration '**premature expiratory cycling**' or too late when the

patient has already tried to breathe out against inspiratory pressure '**delayed expiratory cycling**'. I will explain the individual asynchrony further with an example from my own observations in the methods section (Section 2.5) which have been peer reviewed and published.(79)

**Figure 6: An example of different asynchronous events as they affect the ventilator delivered breathing cycle**



### **1.9 Extent of the problem –a survey of patient opinion on patient-ventilator asynchrony**

In order to examine the prevalence of PVA and gain an understanding of patient awareness of this issue, a survey was undertaken in non-selected patients with chronic respiratory failure established on non-invasive ventilation whilst awaiting their routine outpatient appointment. (See Appendix 6 for a copy of the survey used).

110 patients (37 female) took part in the survey. The majority of patients had neuromuscular disease (38 patients) or obesity related respiratory failure (ORRF) (36 patients) reflecting the patients requiring non-invasive ventilation in our unit. Fewer patients had COPD (7 patients), COPD/OSA overlap (18 patients) and chest wall disease (CWD) (11 patients). Patient characteristics as described below in Table 4 with ventilator settings for the different disease groups reported in Table 5. PVA was frequent with 61% of patients aware of asynchronous breaths delivered by the ventilator. The commonest type of PVA's described were ineffective efforts affecting 43% of patients followed by autotriggering events reported by 40% of patients. Cycling asynchrony were less common with premature cycling affecting 38% of patients and delayed cycling affecting 30% of patients.

**Table 4: Patients surveyed demographics**

	<b>COPD (7)</b>	<b>CWD (11)</b>	<b>NMD (38)</b>	<b>ORRF (36)</b>	<b>COPD/OSA Overlap (18)</b>
Age (yrs)	61±11	62±14	44±21	57±10	65±9
BMI (kgm <sup>-2</sup> )	31±12	25±4	28±12	44±11	40±6
FEV <sub>1</sub> (L/s)	0.8±0.3	0.7±0.2	0.8±0.4	1.9±1.0	1.2±0.5
FVC (L)	1.6±0.7	0.9±0.3	1.1±0.7	2.4±1.2	1.8±0.8
FEV <sub>1</sub> /FVC (%)	55±21	74±16	80±15	80±9	67±12
Oxygen Saturations on air (%)	90±5	90±10	95±2	95±2	92±6

Results are presented as mean and standard deviation Abbreviations: BMI- Body Mass Index, FEV1- Forced expiratory volume in 1 second, FVC- Forced vital capacity, COPD-chronic obstructive pulmonary disease, CWD-chest wall disease, NMD-neuromuscular disease, ORRF-obesity related respiratory failure, COPD/OSA overlap-combination of chronic obstructive pulmonary disease and obstructive sleep apnoea.

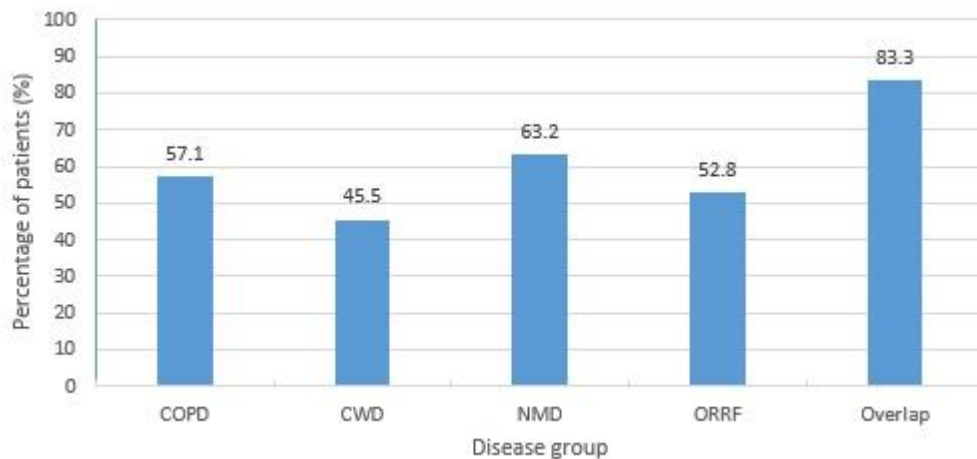
**Table 5: Ventilator settings in different patient groups on HMV**

	<b>COPD (7)</b>	<b>CWD (11)</b>	<b>NMD (38)</b>	<b>ORRF (36)</b>	<b>COPD/ OSA Overlap (18)</b>
IPAP (cmH <sub>2</sub> O)	26 (20-28)	20 (16-30)	20 (16-23)	21 (18-24)	27 (24-30)
EPAP (cmH <sub>2</sub> O)	5 (3-6)	3 (3-7)	5 (3-7)	10 (8-12)	10 (8-12)
BUR (breath/min)	16 (12-18)	14 (10-16)	14 (14-16)	12 (10-14)	14 (10-16)

Results are expressed as median (interquartile range) *Abbreviations:* IPAP= inspiratory positive airway pressure, EPAP= expiratory positive airway pressure, BUR=back up rate

Patients with COPD/OSA overlap were most likely to describe PVA which affected 83% of patients surveyed whereas patients with CWD were least likely to report PVA affecting 46% of patients surveyed. (Figure 8). Ineffective efforts were most frequently reported in patients with COPD/OSA overlap (72%) and least prevalent in patients with ORRF (31%).

**Figure 7: Proportion of patients reporting awareness of PVA in different disease groups**



*Abbreviations:* COPD-chronic obstructive pulmonary disease, CWD-chest wall disease, NMD-neuromuscular disease, ORRF- obesity related respiratory failure, Overlap-combined chronic obstructive pulmonary disease with obstructive sleep apnoea.

Differences were observed in PVA between the different domiciliary ventilators used reflecting the variability in operating characteristics. PVA was most frequently reported by patients using the A30 BIPAP (Philips Respironics, Murrysville, Pa, USA) (78%) followed by S9 VPAP S (ResMed, San Diego, Ca, USA) (72%), NIPPY 3+ (B&D Electromedical, Stratford-upon –Avon, UK) (58%), BiPAP Harmony (Philips Respironics, Murrysville, Pa, USA)(52%).

PVA was most commonly reported in patients (82%) who had started domiciliary ventilation within the last year. There was a gradual decline in patients reporting PVA with time on ventilation with 60% of patients affected having used NIV between 1-3 years and only 38% of patient affected who were established on NIV between 4-8 years. A further increase in patients reporting PVA was observed in the long term group (>10 years) (62%) although this may be in part related to this group containing the fewest patients surveyed (19).

In summary, we found that patient reported awareness of PVA is higher than PVA levels described in the literature and affects a majority of patients requiring long-term non-invasive ventilation.(18, 75, 80) A limitation of this survey is that there was not an objective physiological measure of PVA to compare with the self-reported PVA by the patients, but importantly these data highlight that the patients perceive this as a clinical problem.

## **1.10 Potential consequences of patient-ventilator asynchrony**

### **1.10.1 Ultrastructural injury to respiratory muscles**

Ventilator delivered breaths during expiration i.e. respiratory muscle relaxation and lengthening may force sudden respiratory muscle contraction that is thought to lead to muscle damage. In animal models contraction of skeletal muscle during lengthening can lead to muscle fibre injury and decreased ability to generate force.(81, 82) Evidence from ventilation in acute lung injury has suggested that ventilator settings must be balanced to prevent total muscle inactivity resulting in loss of muscle mass and strength on the one hand and sustained increased work of breathing causing structural damage and inflammation on the other.(83-85)

### **1.10.2 Increases work of breathing**

Patient inspiratory efforts that fail to trigger the ventilator results in wasted work of breathing, as the respiratory muscles contract, consume oxygen but do not generate an effective tidal volume or gas exchange. This may prevent respiratory muscle unloading and in fact increase the work load on the respiratory muscles. Work by Nava *et al.* measured work of breathing of the diaphragm using the pressure-time product of the diaphragm (PTP).(86) The PTP was described by Fields *et al.*, calculated as the mean transdiaphragmatic pressure multiplied by the duration of diaphragmatic muscle contraction and closely correlated with the oxygen consumption of the inspiratory muscles.(87) Nava *et al.*, observed a higher PTP to be associated with more ineffective efforts and that these occurred with higher pressure support levels in patients with COPD.(8, 86) Leung *et al.* found the PTP of the diaphragm to be 38% higher during wasted patient efforts compared to triggered breaths.(8) Thille and colleagues identified that wasted patient efforts accounted for more than fifteen percent of the total work of breathing per minute in patients with difficulties weaning from mechanical ventilation.(88)

### **1.10.3 Impairs pulmonary mechanics and gas exchange**

Double triggering and auto-triggering occurring during patient expiration may lead to effective 'breath stacking' and increased inspired tidal volume. As explained above (1.5.2), in patients with expiratory airflow limitation this may lead to dynamic hyperinflation, increased end expiratory positive pressure and therefore an increased threshold load for the patient to work against in order to trigger the ventilator.(13, 82) A similar phenomenon occurs with delayed cycling, where the ventilator continues to deliver inspiratory support whilst the patient is breathing out. This also decreases the patient's

expiratory time and may lead to gas trapping and dynamic hyperinflation, in those with airflow obstruction.(13) Both of these mechanisms may adversely affect gas exchange through increased dead space ventilation and ventilation- perfusion mismatching. Work by Fanfulla *et al.* demonstrated that ineffective efforts seen overnight were correlated with an increased time spent with saturations below 90% in patients with chronic respiratory failure receiving domiciliary ventilation. (76)

Frequent auto-triggering may effectively hyperventilate the patient leading to hypocapnia and respiratory alkalosis.(82)

#### **1.10.4 Induces patient discomfort**

PVA may induce patient discomfort; clinical experience has shown that patients poorly tolerate situations where they appear to be 'fighting the ventilator'. In invasively ventilated patients, Vitacca *et al.* identified increasing proportions of ineffective efforts and discomfort with high levels of pressure support although a significant correlation was not seen.(18) In a study of 65 non-invasively ventilated patients, Vignaux and colleagues demonstrated a significantly improved comfort measured by a visual analogue score in patients with an asynchrony index (AI) less than 10 percent of breaths ( $p=0.027$ ). (89) Work by Moerer *et al.* comparing neural triggering of non-invasive ventilation against pneumatic triggering in healthy subjects found a significant correlation between subject comfort scores and the amount of asynchrony in pneumatic triggering.(90)

#### **1.10.5 Increases sleep disruption**

PVA may lead to microarousals and increased sleep fragmentation. Work by Fanfulla *et al.* performed in neuromuscular disease patients receiving domiciliary non-invasive ventilation demonstrated that more frequent ineffective efforts was associated with less time spent in rapid eye movement (REM) sleep.(75) Bosma *et al.* studied PVA in patients weaning from invasive mechanical ventilation. This study identified that PVA per hour were more frequent during pressure support ventilation compared to proportional assist ventilation and these correlated significantly with the number of arousals per hour ( $r^2=0.65$ ,  $p=0.0001$ ). (91) A further detailed study performed by Guo *et al.* in 20 patients with obesity hypoventilation syndrome suggested that patient ventilator asynchrony was associated with fragmented sleep and a reduction in slow wave and REM sleep. A majority (2/3) of the microarousals were seen in stage 1 and 2 non-REM sleep which may reflect the enhanced neural drive to the respiratory muscles observed in lighter stages of sleep.(70)

### **1.10.6 Increases time spent on mechanical ventilation**

Clinicians frequently use the respiratory rate as a parameter to assess a patient's ability to wean from invasive mechanical ventilation. Respiratory rate is often measured by the ventilator, as ineffective efforts are not detected by the ventilator the true respiratory rate may be much higher than the measured respiratory rate and impact on weaning decisions. (92) The presence of asynchrony has also been shown to reduce the likelihood of successful weaning from mechanical ventilation and increase sedation levels. (93) Chao *et al.* demonstrated that 16% of patients with ineffective efforts successfully weaned from invasive ventilation after 30 days of ventilation compared to 57% of patients without ineffective efforts.(58) Those that managed to wean from ventilation took an average of 72 days to wean compared to 33 days in those without ineffective efforts.(58) Thille *et al.* identified similar results in patients with an asynchrony index more than 10% who had a longer duration of mechanical ventilation and were more likely to require a tracheostomy.(77) Work from de Wit *et al.* describes a significant association between increased ineffective efforts and longer time spent on mechanical ventilation.(78) This also translated into an increased ICU and hospital stay as well as a reduced likelihood of being discharged home. However, overall no differences in mortality outcomes have been observed.

## **1.11 Summary**

It remains to be explained whether PVA is simply a reflection of patients with complex pulmonary mechanics preventing synchronous interaction with the ventilator or if it is PVA that directly affects patient outcomes whereby correcting these is a worthwhile endeavour. In this thesis I will attempt to identify the prevalence of PVA in patients on HMV and identify the relationship to important patient outcomes such as gas exchange, patient adherence to HMV therapy, patient quality of life measures and markers of sleep quality.

## **Chapter 2 Material and Methods**

### **2.1 Ethical Approval**

The studies in this thesis were approved by the Harrow National Research Ethics Service, London and the research and development at Guys and St. Thomas' NHS Foundation Trust. The studies were performed in the Lane Fox High Dependency Unit of St. Thomas' Hospital. All subjects were provided with information leaflets regarding the study and gave their written consent to participate. When written consent was not possible due to neuromuscular weakness verbal consent was obtained that was countersigned by an independent member of the research team or a patient advocate.

### **2.2 Subjects**

Healthy subjects were recruited from Guy's and St. Thomas' Hospital staff, research colleagues from the London Respiratory Muscle Group and their friends or relatives.

Patients with hypercapnic respiratory failure related to chronic obstructive pulmonary disease (COPD), obesity hypoventilation syndrome (OHS), neuromuscular disease (NMD) and chest wall disease (CWD) were screened and recruited from referrals to the Lane Fox High Dependency Unit, St. Thomas' Hospital for the initiation of home mechanical ventilation.

### **2.3 Anthropometrics**

After informed consent, the subject's date of birth and gender were recorded. Height was measured using a portable Leicester height measure (Invicta Plastics Limited, Oadby, Leicester, range 14-210cm) where height measurement was not possible (for example in patients with Duchenne muscular dystrophy) an arm span measurement by a flexible standard medical tape measure was made. Weight was measured using a medical scale (SECA, maximum capacity 160kg). Body-Mass-Index (BMI) was calculated as  $\text{weight (kg)} / (\text{height (m)})^2$ . Waist measurements were obtained at the midpoint between the lower costal margin and the iliac crest and hip measurements were obtained at the point of maximal lateral protrusion of the hips with a standard medical tape measure. Waist-to-hip ratio was calculated as  $\text{waist (cm)} / \text{hip (cm)}$ .

### **2.3.1 Measurement of Fat Free Mass**

Single frequency bioelectrical impedance (Bodystat 1500, Douglas, UK) was used to calculate the fat free mass of study participants. The technique involves passing a small current at 50Hz between surface electrodes placed on the dorsal aspect of the hand and foot. The Bodystat calculates the voltage drop between the electrodes and therefore the total body impedance. The test assumes that adipose tissue has a low water content and is therefore of high electrical impedance whereas the fat free mass has a high water content and has a lower electrical impedance. Predictive equations that incorporate age, heights, weights and genders are used to calculate the fat free mass of a subject from an impedance value. Regression equations exist to optimise accuracy and have been validated against alternative methods for measuring body composition such as dual energy x-ray absorptiometry (DEXA) in COPD patients. (94)

### **2.4 Arterial blood gases**

Arterial puncture was obtained by manually palpating the radial pulse and performing an arterial blood gas using a Roche MICROSAMPLER PROTECT (Roche Diagnostics Ltd, Indianapolis, IN, USA) needle and self-filling syringe. A full aseptic technique was employed. Patients were seated at rest and on room air. The blood samples were analysed on a Cobas b221 (Roche Diagnostics Ltd, Indianapolis, IN, USA) benchtop arterial blood gas analyser that was calibrated on a daily basis by the technical services team on Lane Fox Unit as for routine clinical care.

### **2.5 Questionnaires**

Questionnaires were filled out by the subjects with the investigator ensuring that the whole questionnaire was completed. Occasionally either the investigator or a relative read out the questions if the patient was unable to read or had forgotten their glasses. Where patients were unable to manually complete the questionnaire the appropriate response was verbalised by the patient and noted by the research investigator. There was no time limit within which the patient was required to complete the questions.

### **2.5.1 Epworth Sleepiness Scale (ESS)**

Tiredness and fatigue are common symptoms but daytime somnolence maybe a marker of underlying sleep disordered breathing leading to frequent arousals and sleep disruption. The Epworth sleepiness scale was validated to differentiate between pathologically sleepy states associated with diseases such as obstructive sleep apnoea, narcolepsy and idiopathic hypersomnia from snoring or healthy matched subjects.(95) The values are weakly correlated to sleep latencies during polysomnography and sleep latency testing. The ESS is commonly used to monitor a patient's response to treatment of sleep disordered breathing associated with respiratory failure.(39) The scale consists of eight questions each with a score of 0 to 3 points.

### **2.5.2 Fatigue Severity Score (FSS)**

The FSS consists of 9 items each with a 7 point scale to measure fatigue severity in neurological and medical conditions. A higher score relates to more severe symptoms of fatigue and has been validated against a visual analogue score.(96)

### **2.5.3 Hospital anxiety and depression score (HADS)**

The HADS is a 14 item scale with a score ranging from 0-42, where a higher score represents more severe symptoms. The questionnaire was initially developed as a screening tool to detect anxiety and depression in patients with physical symptoms.(97) Seven items of the HADS relate to depressive symptoms and seven items relate to anxiety each item has a possible score of 0-3. The HADS has now been validated to grade the severity of anxiety and depression of a patient from normal to severe. The data returned from the HADS is ordinal.(97)

### **2.5.4 Severe Respiratory Insufficiency Questionnaire (SRI)**

Patients with respiratory failure arising from many underlying pathologies receive domiciliary ventilation. Although the underlying mechanisms leading to ventilatory failure may differ, the impact on respiratory patterns during sleep and the symptoms experienced by the patients may be similar across different diseases. The SRI questionnaire comprises of 49 questions producing a summary and 7 sub-domain scores. The higher the total score, the better the quality of life (range 0-100). The questionnaire has been validated in patients with a range of disorders using home mechanical ventilation and has been shown to be reproducible and correlates to other generic measures of health related quality of life.(98)

### **2.5.5 St. George's Respiratory Questionnaire**

The St. George's respiratory Questionnaire (SGRQ) is a health related quality of life questionnaire developed to measure the health status of patients with airways obstruction.(99) It is a 50 item questionnaire that assess 3 domains of symptoms, activity and impacts providing a total score. Scores are expressed as a percentage of the overall impairment with 0 representing no impairment and 100 representing maximal impairment. Subjects are requested to recall their symptoms over the previous 3 month period for the assessments used in this thesis. The questionnaire has been validated in a number of clinical trials and has demonstrated both repeatability and reliability.(100, 101) The SGRQ has correlated well with markers of disease activity such as cough, dyspnoea, 6-minute walk test and FEV<sub>1</sub>. (102, 103) A minimum change in score of 4 has been demonstrated to be clinically relevant.(104)

### **2.5.6 36-Item Short Form Health Survey (RAND-36)**

The RAND-36 is a health related quality of life questionnaire developed by the RAND Corporation as part of the Medical Outcomes Study (MOS).(105) It is comprised of 36 items that assess eight health sections: physical functioning, role limitations caused by physical health problems, role limitations caused by emotional problems, social functioning, emotional well-being, energy/fatigue, pain, and general health perceptions. Each section is scored on a scale from 0-100 with a higher score reflecting a better quality of life.

### **2.5.7 Visual Analogue Scores (VAS)**

A VAS is a horizontal line 100 millimetres in length that is anchored by opposite word descriptors at each end of the line used to measure an opinion or symptom that is a continuum. An example is measuring pain, which may be considered to have a continuous dimension of severity and could be anchored by no pain against severe pain. The patient marks along the line the point that represents their perception of their current status. The VAS score is measured along the line in millimetres to the point where the patient makes a mark. There is a possible score of 0-100 with a higher score representing an improvement in symptoms.(106) The VAS has been shown to be superior to some other measures of health related scores.(107) In this thesis, the VAS was used to assess participants comfort receiving non-invasive ventilation and their perceived co-ordination with the ventilator.

## **2.6 Pulmonary function and respiratory muscle testing**

Spirometry tests were performed using a handheld spirometer (Williams Medical, Rhymney, UK) by a trained health care professional in accordance with the ATS/ERS consensus statement (2005).(22) The study participants were asked to maximally inspire and then to exhale forcibly, as hard and as fast as possible through the mouthpiece until there was nothing left to expel. The spirometer then recorded the forced expired volume over the first second (FEV<sub>1</sub>) and the forced vital capacity (FVC), i.e. the total volume expired. The procedure was repeated three times or until there were two readings within 100ml. The best result was used for the studies. The result was compared to the predicted normal values that are adjusted for age, gender and height to provide the percent predicted value. The ratio of FEV<sub>1</sub> to FVC was compared in all subjects. A cut off <70% was used to identify patients with obstructive airways disease and >70% to identify patients with restrictive lung disease.

### **2.6.1 Pneumotachography flow assessment**

A heated pneumotach (PNT Series 3830, Hans Rudolph, Shawnee, KA, USA) manufactured for flow rates between 0-400 litres/minute was attached to the face mask of patients on non-invasive ventilation to assess flow. The flow signal was processed integrated into the LabChart v 7.3 using the spirometer software. From this we could calculate the tidal volume (as the area under the curve of the flow signal) achieved for each breath when interacting with the ventilator. For safety reasons with the heating system this was only used for studies under the direct observation of the research team. To ensure accuracy calibration checks were performed prior to each study using a fixed volume 3 litre syringe discharged and different flow rates between 0.5L/s and 12L/s as per the American Thoracic Society/European Respiratory Society (ATS/ERS) Task Force standardisation of lung function guidelines.(22) The volume at each flow rate was checked to ensure any discrepancy was kept below 3.5%.

### **2.6.2 Respiratory Muscle Strength**

Non-invasive assessment of respiratory muscle strength including maximal inspiratory pressure (MIP), sniff nasal inspiratory pressure (SNIP) and maximal expiratory pressure (MEP) were carried out using a handheld device (Micromedical Ltd, Kent, UK) in accordance with ERS/ATS guidelines.(24) In the neuromuscular patient group, cough peak flow was also obtained using a handheld peak flow meter.

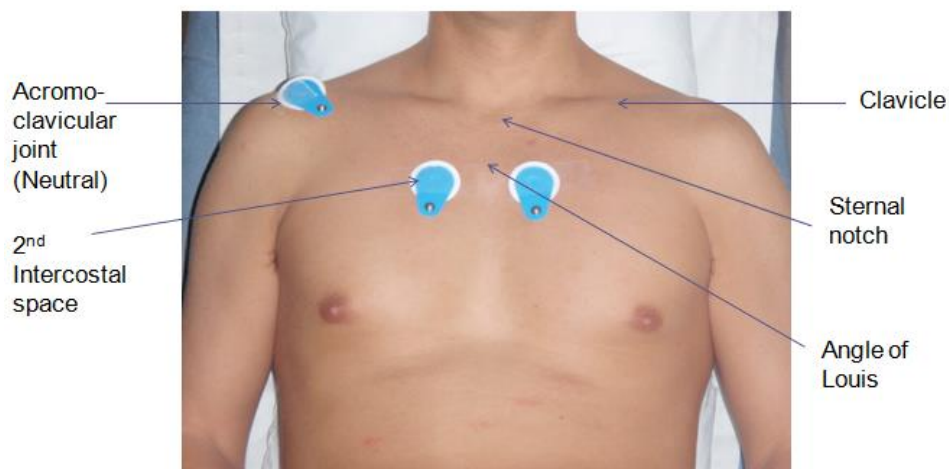
A mask interface was used and patients were asked to cough into the peak flow meter. For all tests the best of three were obtained, further tests were performed until there were two results within 5 percent of each other.

## **2.7 Measures of Neural Respiratory Drive**

### **2.7.1 Measurement of surface parasternal EMG (sEMGpara)**

The second intercostal parasternal space was identified using bony landmarks (the sternal notch and the angle of Louis) and the skin was prepared using EMG contact gel (Nuprep, DO weaver and Co, USA). Silver-silver chloride wet gel electrodes (Neuroline 720, Ambu, Denmark) were placed adjacent to the sternum in the second intercostal spaces. (Figure 9). The signal was amplified and processed using two high differential amplifiers with band pass filters set at 10Hz and 2000Hz (Bioamp, ADInstruments, Chalgrove, UK). Additional adaptive mains filters were applied and AC coupling was used. Amplified signals underwent analogue to digital conversion (Powerlab, ADInstruments, Chalgrove, UK) and passed to a desktop computer. Further digital filtering occurred at 20Hz after data acquisition and signals were analysed using signalling software (Labchart v7.3, ADInstruments, Chalgrove, UK). sEMGpara signals were recorded with the subject relaxed in a semi-recumbent position in bed with arms fully supported.

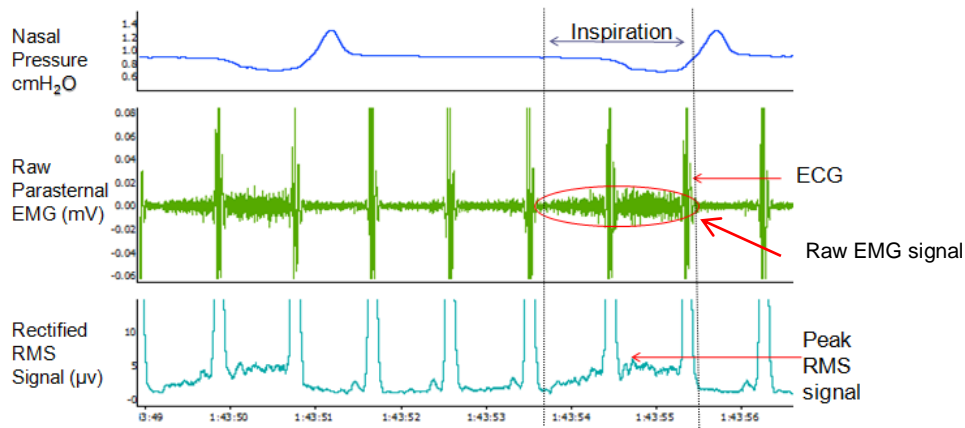
**Figure 8: Positioning of second intercostals surface parasternal EMG electrodes (sEMGpara)**



sEMGpara signals for maximal manoeuvres and tidal breathing were recorded post 10 minutes of stable breathing at the beginning of the overnight traces. To normalise the signals facilitating comparison of results between patient groups the signal was expressed as a percentage of the maximal signal obtained during maximal inspiratory manoeuvres (sEMGpara%max). This normalised sEMGpara%max signal reduces the effect of between patient and between occasion variation in skin preparation, electrode placement and subcutaneous tissue impedance. (Figures 10 and 11).

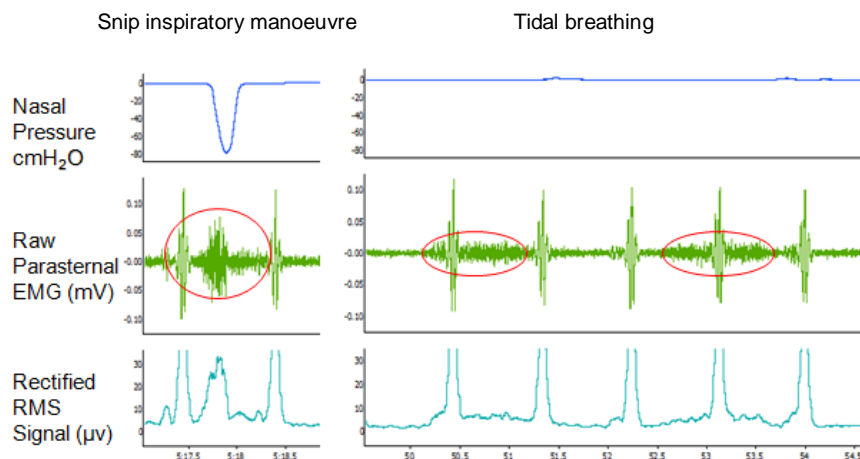
sEMGpara signals were analysed using the breath-by-breath maximal root mean squared (RMS) of the raw sEMGpara signal with a moving window of 40ms averaged over a 2 minute period. This was then normalised to the maximum RMS sEMGpara value obtained during a maximal inspiratory manoeuvre (sEMGpara%max).

**Figure 9: A representative trace of a raw sEMGpara signal with rectified RMS signal**



*Abbreviations:* ECG- electrocardiogram, EMG-electromyogram, RMS- root mean square of the raw parasternal electromyogram signal.

**Figure 10: A representative trace of a raw sEMGpara signal during tidal breathing and a maximal inspiratory manoeuvre that is used to normalise the measurement**



*Abbreviations:* Snip-sniff nasal inspiratory pressure, EMG-electromyogram, RMS-root mean square of the raw electromyogram signal.

### 2.7.2 Difficulties encountered in using surface parasternal EMG measurements for continuous monitoring

Ensuring reliable signals that are free from artefact is paramount to work with surface EMG and its utility to detect patient inspiratory effort. Surface EMG measurements are known to be easily contaminated from cross-talk signals from adjacent muscle activity.(30) Signals are also affected by the impedance of both skin and subcutaneous fat that reduces the signal strength.(30) This can

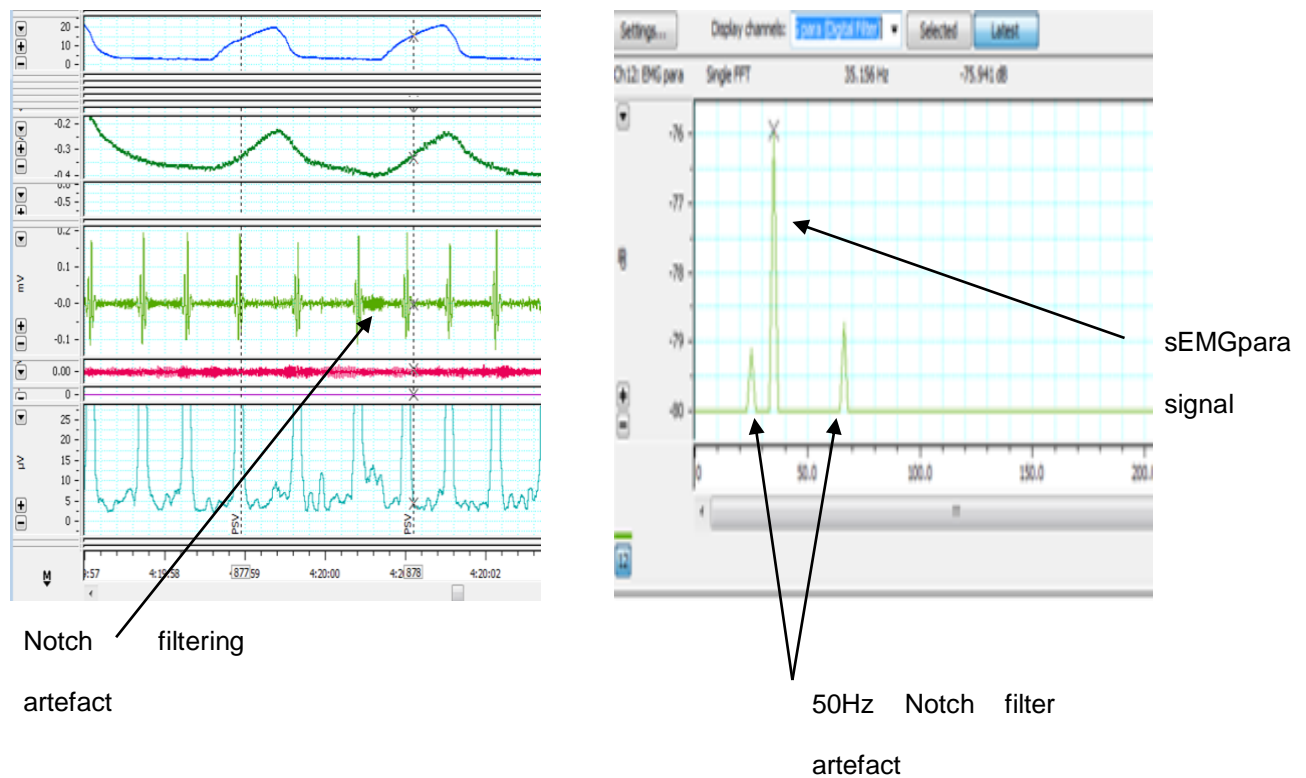
partially be improved with the use of good skin preparation to remove dead skin cells and any moisture but makes signals in obese patients more difficult to detect above noise levels. Surface EMG recording can also be affected by mains noise and external electrical interference.(30) Filtering the signal helps to guard against these artefacts.

Initial signals were filtered using a 50Hz analogue notch filter in addition to the band pass filters set at 10Hz and 2000Hz to eliminate the noise from the mains power supply which runs at 50Hz. We found however that this filter produced an interference termed 'ringing' at fixed intervals either side of 50Hz and degraded the signal that arose in the 50Hz range that includes muscle unit firing frequencies. The signals were assessed with a spectral frequency analysis to confirm or exclude artefact. (Figure 12). In addition, due to slight variations in the power supply to the hospital, the noise signal may contain harmonics of the noise and the exact frequency of the noise may vary.

Subsequently we used an adaptive mains filter which identifies both the patient signal and signals from the power supply directly. The adaptive filter is then able to track the actual frequency of the noise as it fluctuates and improves the signal quality.

Before recruiting for the randomised control trial, I performed studies in nine subjects in order to optimise the EMG signal I obtained. I spent time practising skin preparation, electrode placement techniques and addressing the above signal filtering issues.

**Figure 11: An example of notch filter artefact affecting sEMGpara signals**



*Abbreviations:* sEMGpara: surface second intercostal parasternal electromyogram signal, Hz-hertz

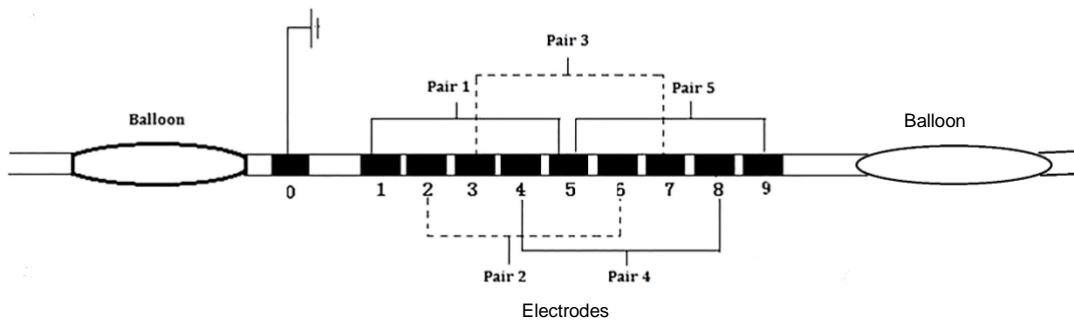
### 2.7.3 Measurement of Diaphragm EMG

A disposable multipair electrode catheter (Yinghui Medical Technology Co., Ltd, Guangzhou, China) was inserted per-nasally. (Figure 13). The oesophageal catheter consists of five pairs of electrodes. The catheter was positioned based on the amplitude of the crural diaphragm EMG (EMGdi) recorded from five pairs of electrode. Optimal position was characterised when the largest EMG amplitude recorded from pairs 1 and 5 and the smallest EMG signal recorded from pair 3 and was then fixed at the nose to ensure consistency.(30, 108, 109) The EMGdi signals were amplified and band-pass filtered between 20 Hz and 1 kHz (Bioamp, AD Instruments, Chalgrove, UK). Amplified signals underwent analogue to digital conversion (Powerlab, ADInstruments, Chalgrove, UK) and were passed to a desktop computer. After data acquisition, signals were analysed using signalling software (Labchart v7.3, ADInstruments, Chalgrove, UK).

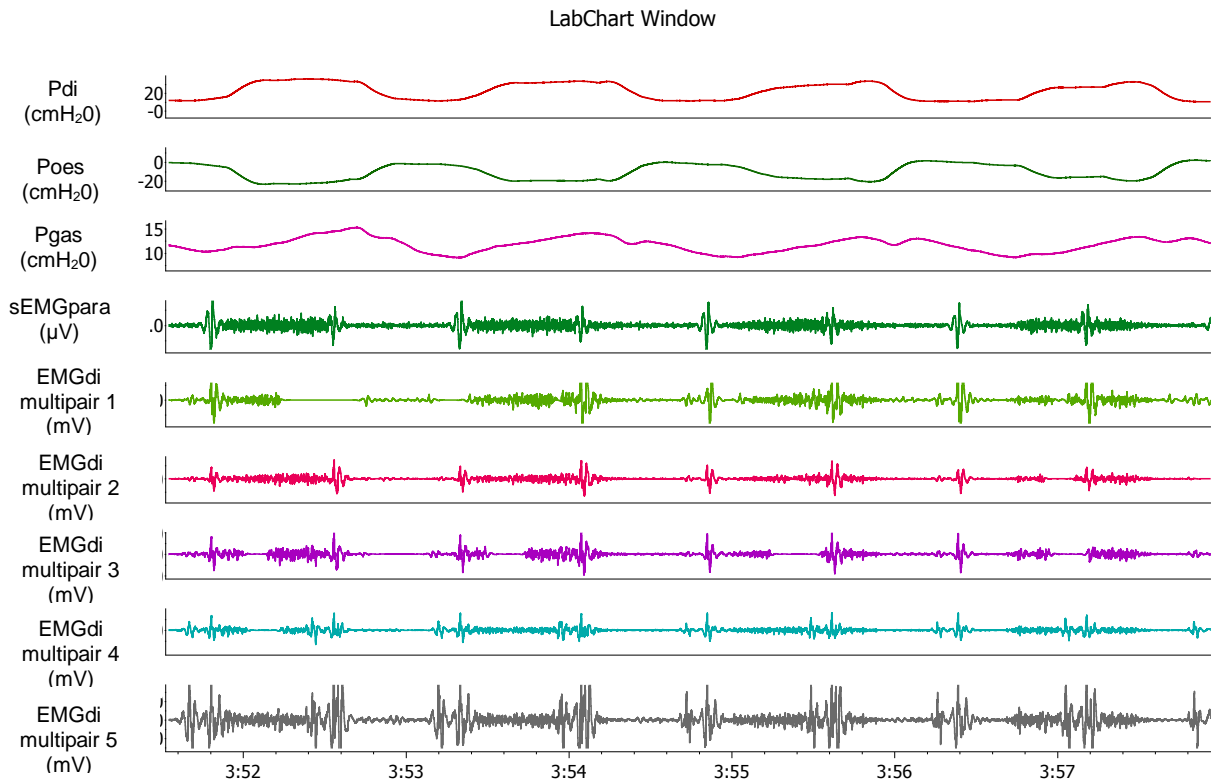
The multipair electrode catheter has two 9.5cm long balloons with an uninflated circumference of 1cm. The gastric balloon is attached 5cm from the tip of the catheter and is separated from the oesophageal balloon by 14 cm (Yinghui Medical Technology Co., Ltd, Guangzhou, China). Once

positioned the balloons were connected to a pressure transducer (GM Instruments Ltd, Kilwinning, UK) to simultaneously measure the oesophageal and gastric pressures (110). The connection was secured with a 3 way tap to ensure the balloons could be inflated post being swallowed by the subject. The position of the catheter balloons were assessed by reviewing the pressure tracing obtained from each balloon. Distal balloon placement in the stomach was confirmed by a positive pressure reading which is confirmed by gently compressing the abdomen leading to an increase in positive pressure reading on the manometer ( $P_{gas}$ ). The oesophageal balloon placement was ascertained by reviewing the pressure reading that corresponds to a negative deflection with inspiration and maybe confirmed by the presence of cardiac oscillations ( $P_{oes}$ ). The  $P_{oes}$  provides a marker of pleural pressure (111), the  $P_{gas}$  provides a marker of abdominal pressure (112) and from these the transdiaphragmatic pressure ( $P_{di}$ ), a measurement of diaphragmatic strength can be calculated ( $P_{di}=P_{gas}-P_{oes}$ )(113).

**Figure 12: Diagram example of the balloon catheter with mounted EMG electrodes.(114)**



**Figure 13: A representative trace acquired from simultaneous diaphragm and parasternal electromyography**



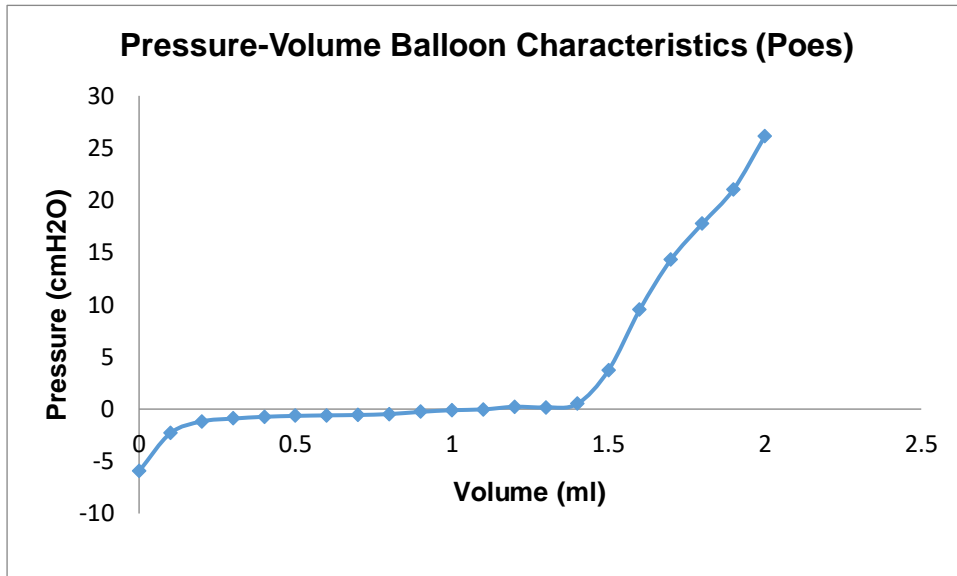
*Abbreviations:* Pdi-transdiaphragm pressure, Poes-oesophageal pressure, Pgas-gastric pressure, sEMGpara-surface second intercostal electromyogram, EMGdi- diaphragm electromyography, multipair- pairs of diaphragm electromyogram electrodes according to the configuration demonstrated in Figure 13.

### 2.7.4 Pressure-volume characteristics of the nasogastric catheter balloons

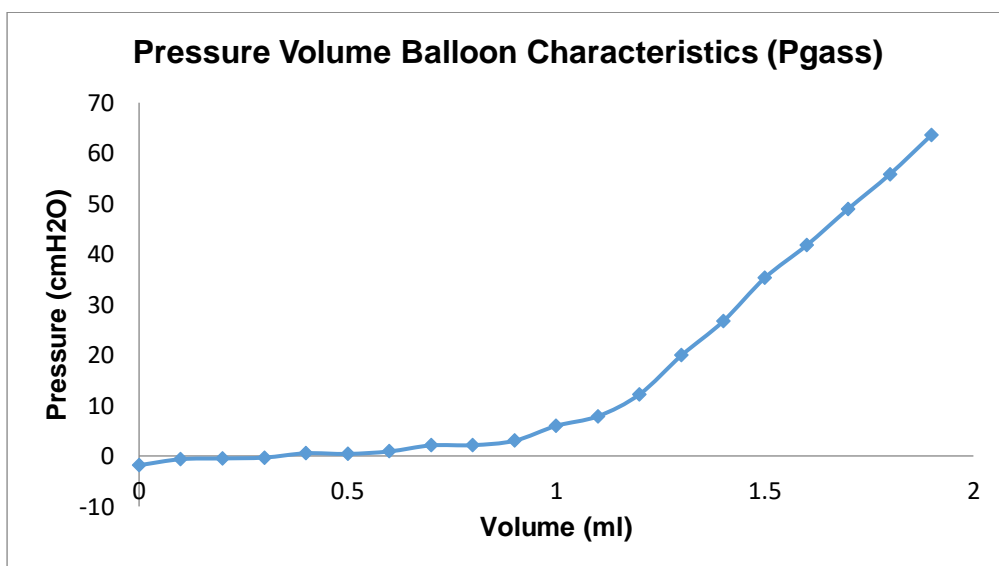
The accuracy of the catheter balloons in recording pressure measurements depend on their compliance and the volume of air they are filled with. The balloons were filled with 0.1ml aliquots of air in a stepwise fashion between 0.0ml and 3.0ml and the pressure that was transmitted was measured using a handheld pressure meter (Fisher Scientific UK Ltd, Loughborough, UK). Figures 15 & 16 identify an optimal range of balloon filling pressures between 0.5ml and 1.4ml for the oesophageal balloon and 0.2-0.8ml for the gastric balloon. Below 0.2ml for the gastric balloon and 0.5ml for the oesophageal balloon the pressure measurements become more negative due to the initial balloon properties that must be overcome to expand. Above 0.8ml for the gastric balloon and 1.4ml for the oesophageal balloon measurements become positive non-linear measurements due to contracting forces. The best volume to assess negative pressures like Poes was to fill the balloon with 0.5ml because of the gas expansion in the relative external negative pressure vacuum created. The

preferred volume for positive pressure measurements like  $P_{gas}$  was 0.8ml because of the compression by the external positive pressure.

**Figure 14: Pressure-Volume characteristics of the oesophageal balloon catheter. Optimal range between 0.5-1.4ml.**



**Figure 15: Pressure-Volume characteristics of the gastric balloon catheter. Optimal range between 0.2-0.9ml**



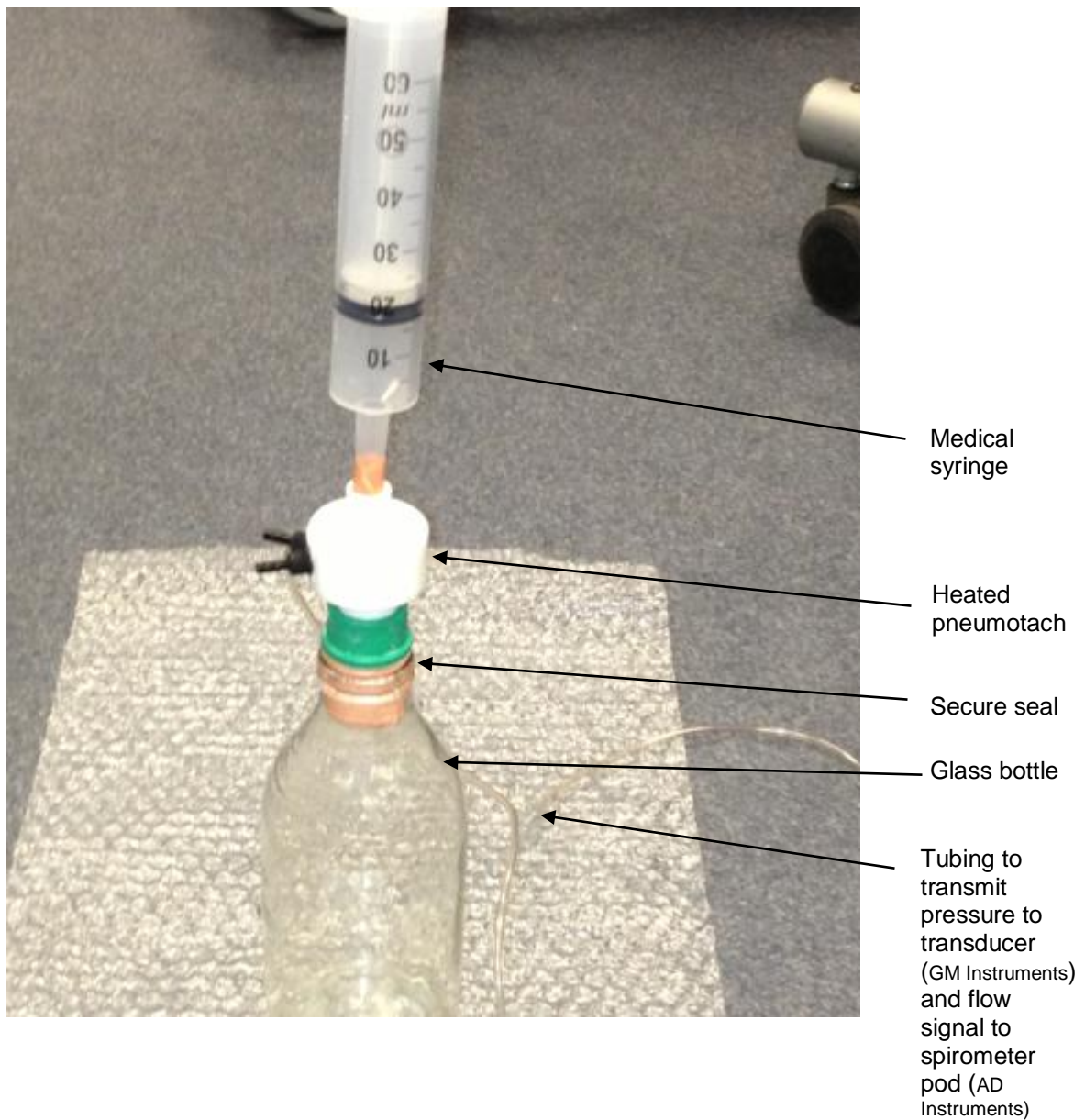
### **2.7.5 Pressure Transducer calibration**

Pressure transducers (GM Instruments Ltd, Kilwinning, UK) were used for obtaining SNIP, MIP, MEP measurements, identifying the phases of tidal breathing and the ventilator output in response to the subject's respiration. These were provided with a manufacturer's certificate of accurate measurement over a pressure range (+/- 200cmH<sub>2</sub>O). The pressure transducers readings were also checked prior to each study against a hand held pressure transducer (Fisher Scientific UK Ltd, Loughborough, UK) and calibrated with the Labchart (v7.3) (AD Instruments, Chalgrove, UK) software readings.

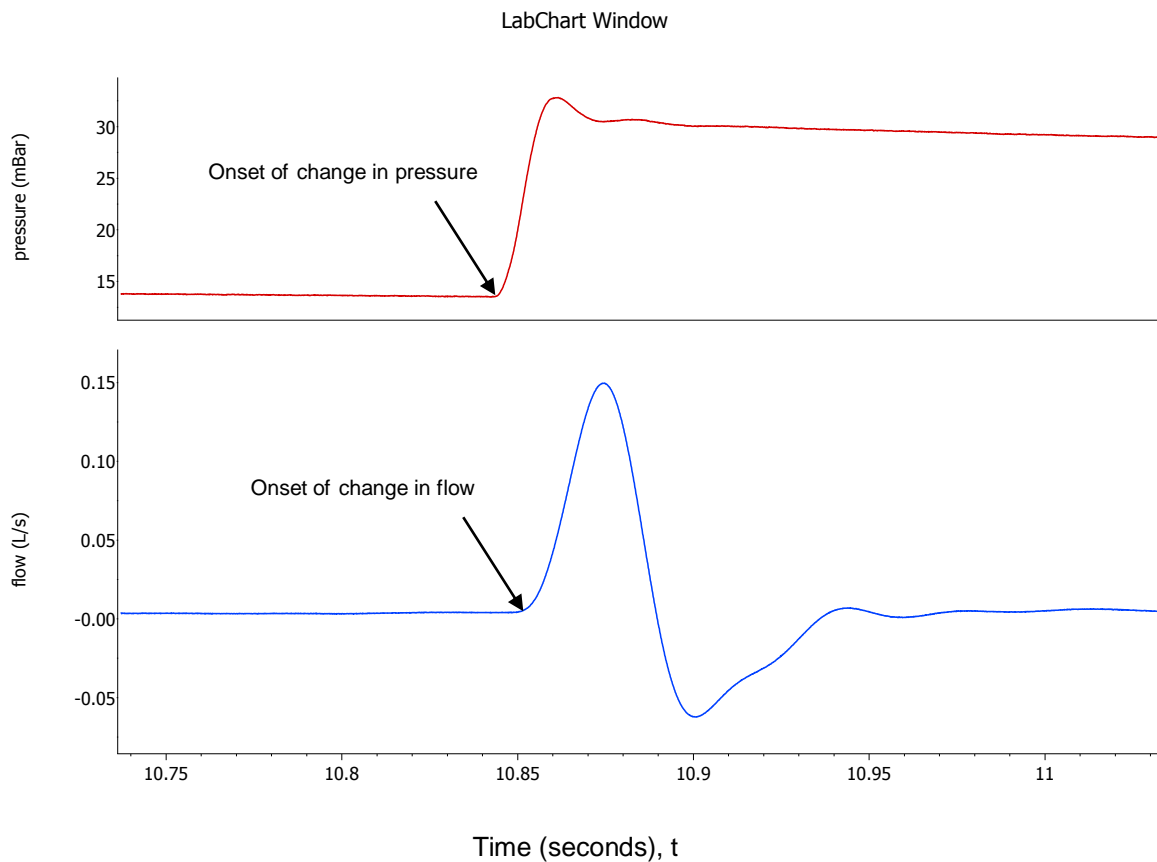
### **2.7.6 Testing for intrinsic delays between pressure and flow responses**

A 50ml eccentric cone medical syringe (Beckton, Dickinson and Co Ltd, Co.Louth, Ireland) was attached to a heated pneumotach (PNT Series 3830, Hans Rudolph, Shawnee, KA, USA) and a glass bottle and sealed to prevent air leak. (Figure 17). The plunger was advanced with a maximal force to evoke a change in pressure and flow across the pneumotach (PNT Series 3830, Hans Rudolph, Shawnee, KA, USA) attached to a spirometer (AD Instruments, Chalgrove, UK) and generate a pressure signal that could be recorded by the pressure transducer (GM Instruments Ltd, Kilwinning, UK) simultaneously. The onset of the force applied was the same and so any delay observed between the onset of the flow or pressure signal would represent a true delay in the acquisition recording system. The test was repeated 10 times at the maximal time difference recorded between the 2 readings was <0.006s. (Figures 17 &18).

Figure 16: Equipment used to test for intrinsic delays between pressure and flow responses



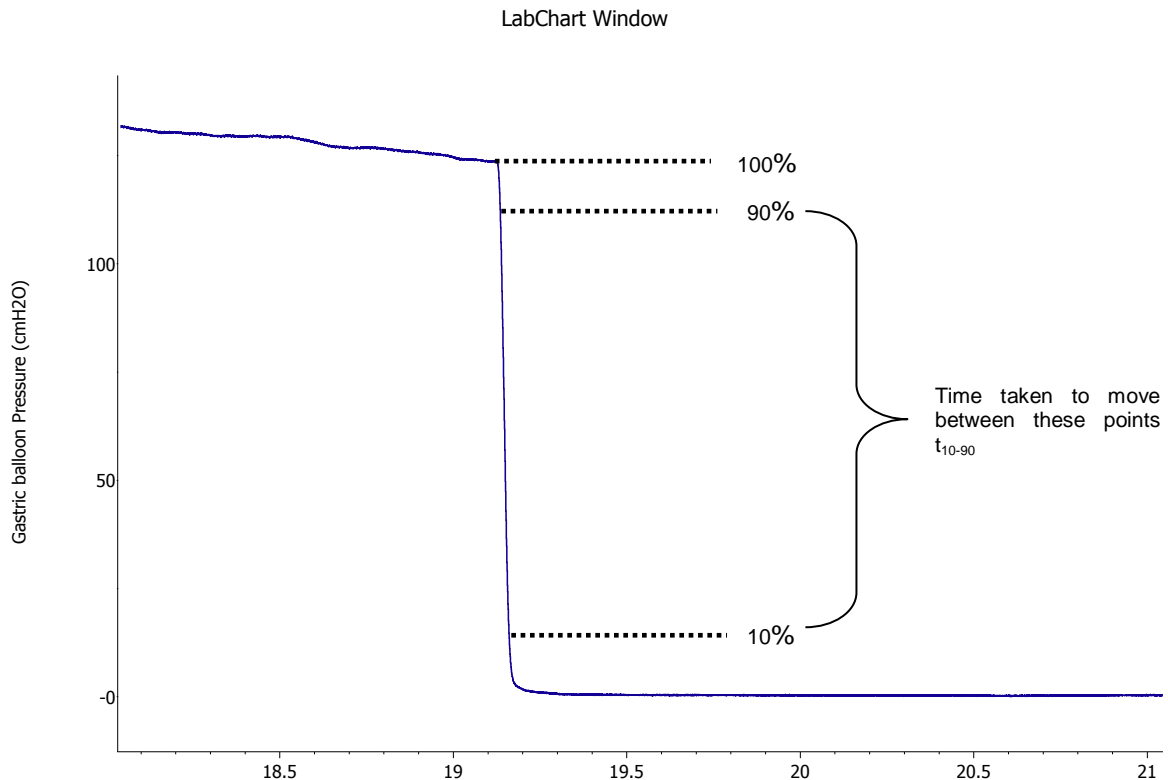
**Figure 17: Raw Labchart data file demonstrating the accuracy of our pressure and flow recordings (time delay between signals <0.006s)**



### 2.7.7 Frequency Response of the Recording System

To test the response of the nasogastric catheter balloon to sudden changes in pressure we carried out a 'pop-test'. The oesophageal balloon was filled with 0.5ml of air and the gastric balloon was filled with 0.8ml of air and each was independently placed inside a larger balloon with an external pressure applied. The external balloon was then popped with a needle and the time taken for the balloon to detect the atmospheric pressure of 0cmH<sub>2</sub>O was recorded. The response time ( $t_{10-90}$ ) of the slope of the pressure decay between 90% and 10% of the initial pressure was calculated. The  $t_{10-90}$  was 0.007s for the oesophageal balloon and 0.005s for the gastric balloon. The frequency response (Fr) was derived from the equation  $(Fr = 3 \times t_{10-90})^{-1}$ . The frequency response of the equipment including the balloon catheter, pressure transducer, amplifier, AD- converter and computer was 47.6Hz for 0.5ml oesophageal balloon and 66.6Hz for 0.8ml gastric balloon.(115)

**Figure 18: Frequency response recording from a ‘pop-test’ using the gastric balloon (Yinghui Medical Technology Co., Ltd, Guangzhou, China) filled with 0.8ml of air.**



## 2.8 Assessment of Sleep disordered Breathing

### 2.8.1 Overnight oximetry and capnography

A combined oximeter-capnometer device (Tosca500, Radiometer, Crawley, West Sussex, UK) was used to record oxygen saturations ( $SpO_2$ ) and transcutaneous carbon dioxide ( $TcCO_2$ ) during sleep. Capnometer probes were calibrated at the start and end of sleep monitoring and the data was outputted in real time to the software (Labchart v7.3, ADInstruments, Chalgrove, UK) as well as being uploaded to a personal computer using Download 2001 (Stowood Instruments, Beckley, Oxford, UK). This facilitated the calculation of 4% oxygen desaturation index, mean  $SpO_2$ , minimum  $SpO_2$ , mean  $TcCO_2$ , maximum  $TcCO_2$ , time spent with  $SpO_2 < 90\%$  and time spent with  $TcCO_2 > 7kPa$ .

### 2.8.2 Respiratory Inductance Plethysmography

Respiratory inductance plethysmography (RIP) bands (Embla, Broomfield, USA) attached to RespiTrace Plus Monitor (SensorMedics, Miami Beach, Florida) were used to assess chest wall and abdominal excursion. The RIP bands consist of two wire coils insulated and placed within two 2.5 cm

wide, lightweight elastic and adhesive bands. The RIP bands are placed around the rib cage at the level of the nipple line and around the abdomen at the level of the umbilicus. They are connected to an oscillator to obtain digital waveforms. During normal, orthodox, inspiration the cross-sectional area of the rib cage and abdomen increases. This alters the inductance of the coils and the frequency of their oscillation, with the increase in cross-sectional area proportional to the change in lung volumes.(116) This was used as a second marker of patient effort to identify inspiration that was incorporated into our definitions of asynchronous events to improve accuracy. The RIP bands were also used to confirm movement artefact affecting the sEMGpara signals.

### **2.8.3 Mask or nasal Pressure monitoring**

Pressure signals were measured by attaching small calibre tubing from nasal cannulae or the mask interface to a differential pressure transducer (GM instruments, Kilwinning, Scotland). The pressure transducer was checked and demonstrated linearity across our range of testing (-150cmH<sub>2</sub>O to 150cmH<sub>2</sub>O). The signals from the pressure transducer are amplified, converted from analogue to digital and displayed on commercial software (Labchart v 7.3, ADInstruments, Chalgrove, UK). Prior to each overnight tracing the calibration of the pressure transducer was checked against a handheld manometer (Fisher Scientific, Loughborough, UK) delivering a fixed pressure measurement to the circuit via a 20ml syringe.

### **2.8.4 Respiratory Polygraphy**

The combination of parasternal, sternocleidomastoid and abdominal surface EMG with respiratory inductance plethysmography and either nasal pressure monitoring (self-ventilation nights) or mask pressure monitoring (nights on non-invasive ventilation) formed our overnight respiratory polygraphy montage.

### **2.8.5 Overnight Polysomnography**

Polysomnography was performed using Alice 5 ® equipment (Respironics ®, Murrysville, PA, USA). Electrical activity of the brain (EEG) was recorded using surface electrodes (Gold) according to the ten-twenty system. Skin preparation was performed using Nuprep ® gel (Weaver & Co, Colorado, USA) and the gold cup electrodes were filled with Ten20 ® conductive paste (Weaver & Co, Colorado, USA). The electrodes were then fixed to the scalp with skin adhesive Tensive (Biopac

Systems Inc, Goleta, CA, USA) and secured with tape. We recorded EEG activity using the recommended configuration (F4M1, F3M2, C4M1, C3M2, O2M1,O1M2), according to the AASM Manual for Scoring Sleep, 2007; Figure 20.(117) F represents frontal electrical activity, C represents central electrical activity and O represents occipital activity. M1 and M2 refer to the reference electrodes over the left and right mastoid processes. Electro-oculography (EOG) was measured using Ambu® neuroline single-use surface electrodes (Ambu Inc, Ballerup, Denmark) to detect rapid eye movement (REM) sleep staging. The electrodes were placed 1 cm below the outer canthus of the eye on the left and 1 cm above the outer canthus of the eye on the right as per the recommended EOG derivations.(117) The same Ambu® neuroline electrodes were used to detect chin EMG movements with one electrode placed in the midline 1cm above the inferior edge of the mandible and another electrode placed 2cm below the inferior edge of the mandible and 2cm lateral to the midline.(117)

**Figure 19: An example of the electroencephalography montage configuration according to the AASM manual for scoring sleep (117)**

*Abbreviations:* M<sub>1</sub>-reference electrode over left mastoid process, M<sub>2</sub>- reference electrode over right mastoid process, F<sub>3</sub>-left frontal electrode, F<sub>4</sub>-right frontal electrode, C<sub>3</sub>-left central electrode, C<sub>4</sub>-right central electrode, O<sub>1</sub>-left occipital electrode, O<sub>2</sub>- right occipital electrode.

### **2.8.6 Scoring sleep stages**

Sleep and respiratory events were scored using standard scoring terminology for adults.(117, 118).

Sleep stages were identified by convention as Stage W (Wakefulness), Stage N1 (NREM1), Stage N2

(NREM2), Stage N3 (NREM3), Stage R (REM) according to the standard criteria.(117) Sleep stages were scored in 30 second sequential epochs from the start of the study with each epoch assigned a stage as appropriate from those listed above. If 2 or more stages were observed within the same epoch then this was scored as that which occupied the majority.(117)

Stage W, is observed if more than 50% of the epoch has alpha rhythm (8-13Hz activity) over the occipital regions or periods of eye blinks, reading eye movements associated with normal or increased chin muscle tone.(117)

Stage N1, is reported if alpha rhythm becomes attenuated and is replaced by low amplitude (4-7Hz activity) and mixed frequency activity for more than 50% of the epoch. There is frequently the presence of vertex sharp waves lasting less than 0.5 seconds over the central region and slow eye movements.(117)

Stage N2 is defined by K complexes, a well-delineated negative sharp wave immediately followed by a positive component lasting more than 0.5 seconds, along with the presence of sleep spindles (distinct waves with a frequency of 11-16Hz) lasting more than 0.5 seconds.(117)

Stage N3 is scored when more than 20% of an epoch contains slow wave activity (0.5-2Hz) with a peak amplitude of more than 75 $\mu$ V over the frontal cortex. Sleep spindles may persist but eye movements are rarely seen.(117)

Stage R is characterised by rapid eye movements which are irregular, sharply peaked eye movements with an initial deflection lasting less than 0.5 seconds. Sawtooth EEG waves may be observed, which are often triangular waves, occurring at a frequency of 2-6Hz and maximal in amplitude over the central regions. These features are often observed in combination with low chin EMG tone.(117)

### **2.8.7 Scoring arousals**

The scoring of arousals from sleep was defined as a rapid shift of EEG frequency lasting for at least 3 seconds during any stage of sleep (N1, N2, N3 or R) preceded by a minimum of 10 seconds of stable sleep.(117) The arousal index (AI) was defined as an average of the number of arousals occurring per hour of sleep throughout the analysis overnight. Normal AI is <10-24 with a wide variation related to aging where an increased arousal frequency is observed as we age.(119)

### **2.8.8 Sleep quality measures**

Total sleep time (TST) was identified as the total time sleep stages were identified from all the epochs examined overnight described in minutes. The total sleep efficiency (SE) was defined as the total sleep time as a percentage of the total sleep opportunity (i.e. between lights off and lights on). Normal SE is described as greater than 80%.<sup>(117)</sup> Markers of sleep disruption were identified as the amount of time spent awake in the night after the first onset of sleep (WASO) measured in minutes and the time it took to first fall asleep termed the sleep latency. Normal SL is described as <30 minutes.<sup>(117)</sup>

### **2.8.9 Scoring respiratory events**

Respiratory events on NIV were scored in accordance with the guidance published by the SomnoNIV group in Thorax in 2010.<sup>(34)</sup> Obstructive events were classified as period of cessation in flow with an initial reduction and then exaggerated abdominal RIP movements whilst the ventilator switches to the back-up rate. (Figure 21). A central apnoea was identified by a cessation in flow without respiratory effort detected from the RIP bands and a switch to the back-up rate. A mixed apnoea was identified as combination of both events. It is characterised by an absence of flow at the mask initially associated without inspiratory effort followed by resumption of inspiratory effort in the second portion of the event without airflow. A hypopnea was defined as a reduction in flow at the mask but not cessation associated with a reduction in RIP band amplitude leading to a desaturation >4% from per-event baseline.

**Figure 20: Example of respiratory events identified from overnight traces as defined by the SomnoNIV group. A) An example of an obstructive apnoea with preserved respiratory effort but reduction in flow. B) An example of central apnoea with an absence in respiratory effort and a reduction in flow interspersed with periods of hyperventilation.(34)**

## **2.9 Non-invasive detection of patient-ventilator asynchrony**

In order to identify PVA, the physician must have a marker of both the patient's inspiratory and expiratory effort to breathe and the ventilator delivered breath. As discussed previously the current accepted method of measuring a patient's breathing effort involves the use of a catheter with a multi-pair electrode placed in the oesophagus for measuring crural diaphragm electromyography (EMG<sub>di</sub>) and pressure measuring balloons placed in the stomach (P<sub>gas</sub>) and oesophagus (P<sub>es</sub>). EMG<sub>di</sub>

provides a real time breath-by-breath measurement of neural respiratory drive (NRD) and reflects the load on the respiratory muscles. EMGdi has been shown as a useful method of monitoring respiratory disease severity, the effect of mechanical ventilation on the respiratory muscle unloading, as well as acting as a direct trigger for mechanical ventilation in neurally adjust ventilator assist mode (NAVA).(23, 120)

However, these catheters are invasive and poorly tolerated in the awake, non-sedated patient which limits their clinical application to assess non-invasive ventilation, particularly in an elective setting. The catheters may be required for monitoring over days whilst ventilatory therapy is administered and would be impractical to maintain in a feeding, ambulatory patient. In addition, neuromuscular patients represent a significant proportion of patients requiring domiciliary ventilation for respiratory failure in our high dependency unit. These patients often have poor bulbar function at the initiation of domiciliary ventilation; the use of these oesophageal, gastric catheters requires good swallow function to pass the tube and would be unfeasible in such patients placing them at risk of aspiration of gastric contents.

The intercostal muscles are obligatory inspiratory muscles and act to stabilise the chest wall against the downward movement of the diaphragm during inspiration.(70) Previous work by Gandevia identified that there was a diminishing cranio-caudal distribution of inspiratory neural respiratory drive to the intercostal muscles which mirrors the mechanical inspiratory advantage of these muscles.(121) Parasternal muscles in the second intercostal space have maximal inspiratory mechanical advantage with associated phasic inspiratory activity, minimal postural tonic activity and demonstrate similar activity to the diaphragm.(121, 122) Previous work using surface electrodes to measure second intercostal parasternal muscle electromyogram (sEMGpara) has demonstrated a direct relationship with respiratory muscle load reflecting NRD.(123) sEMGpara has also been used as a clinically useful alternative monitoring tool in patients with acute COPD, asthma and cystic fibrosis that reflects disease severity and is sensitive to respond to acute changes in disease state.(124-127)

We therefore used sEMGpara as a non-invasive marker of patient inspiratory effort to identify patient ventilator asynchrony. We combined sEMGpara with RIP as a marker of the translation of patient inspiratory effort into chest wall excursion and to identify upper airway obstructive respiratory events overnight. Surface EMG measurements of sternocleidomastoid and abdominal muscles were also

obtained as a further visual marker of the recruitment of accessory inspiratory muscles and muscles of active expiration. Ventilator delivered breaths were identified using the mask pressure (P<sub>mask</sub>). Examples of this technique in identifying individual patient ventilator asynchrony are shown below. (Figures 22-28).

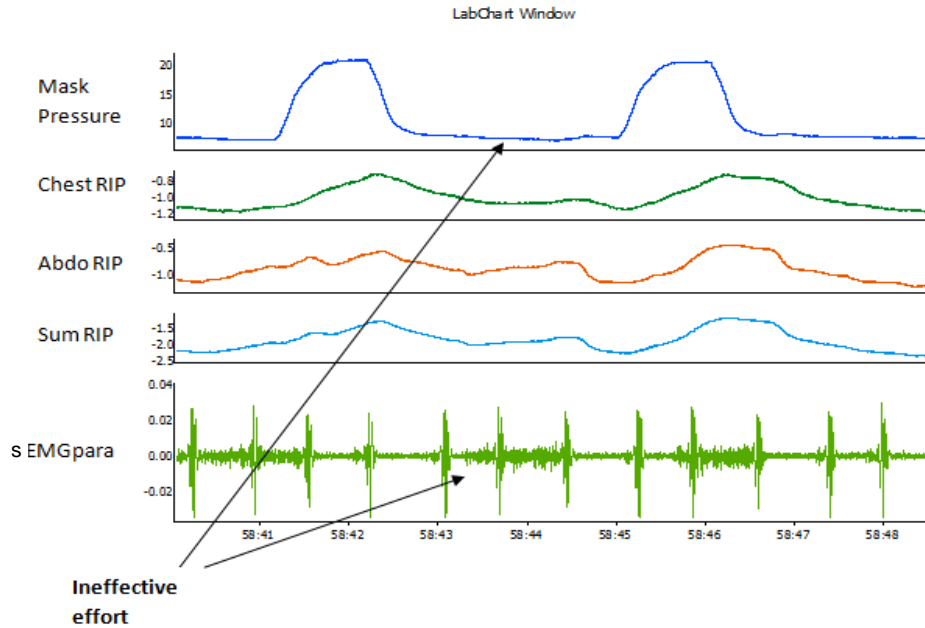
I firstly inspected the overnight studies to identify the asynchrony occurring in non-invasive ventilation using our non-invasive technique. I then set rules for these asynchronous events so that they could be easily characterised and reliably identified between different observers. The overnight polygraphy data were analysed manually examining each breath over 2 minutes for every 10 minutes of recording overnight excluding periods of movement artefact. Below are my definitions for each of the asynchrony in turn with an example, these have now been published. (79)

### **2.9.1 Trigger asynchrony- Ineffective efforts**

An ineffective effort is an asynchronous event where the patient exhibits inspiratory effort demanding a breath without a corresponding breath being delivered by the ventilator.

Visual data definition: sEMG<sub>para</sub> activity (neural respiratory drive) and associated thoraco-abdominal RIP band movement without a corresponding increase in P<sub>mask</sub>. (Figure 22).(79)

**Figure 21: A representative trace identifying an 'ineffective effort' asynchronous event**

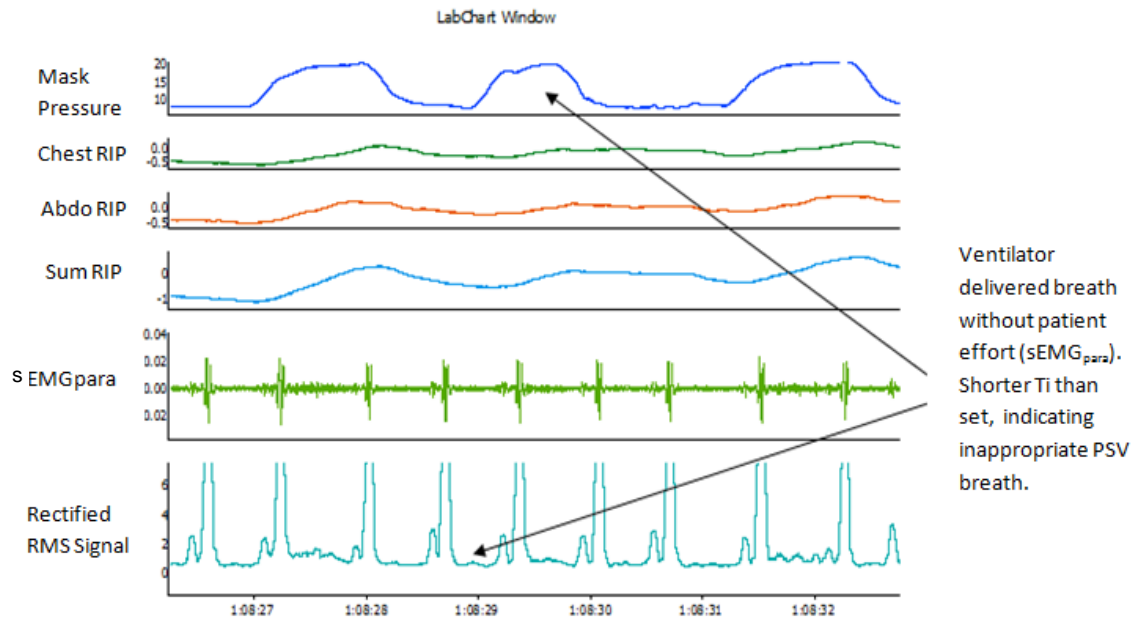


*Abbreviations:* Chest RIP- chest wall respiratory inductance plethysmography, Abdo RIP- abdominal wall respiratory inductance plethysmography, Sum RIP- Sum of both the chest wall and abdominal inductance plethysmography bands, sEMGpara- surface second intercostal parasternal electromyography signal.

### 2.9.2 Trigger asynchrony- Autotriggering

Autotriggering represents an inappropriate ventilator delivered breath that is not triggered by the patient. This mainly occurs as a pressure support delivered breath without corresponding EMGpara activity plus delayed abdominal and chest RIP activity post the onset of the ventilator delivered breath. (Figure 23). It can also occur as a pressure control delivered breath identified by a fixed inspiratory time without sEMGpara activity and delayed abdominal and chest RIP activity post the change in the pressure signal. For the breath to be auto-triggered as a pressure control breath it must be delivered at an inappropriate time when compared to the set back up rate. For example at a back-up rate of 6, a pressure control ventilator delivered breath would be expected every 10 seconds. If a breath was delivered at the preset inspiratory time, 4 seconds after the previous breath without any demand from the patient this would be an auto-triggered pressure control breath.(79)

**Figure 22: A representative trace demonstrating an ‘autotriggered’ asynchronous event**

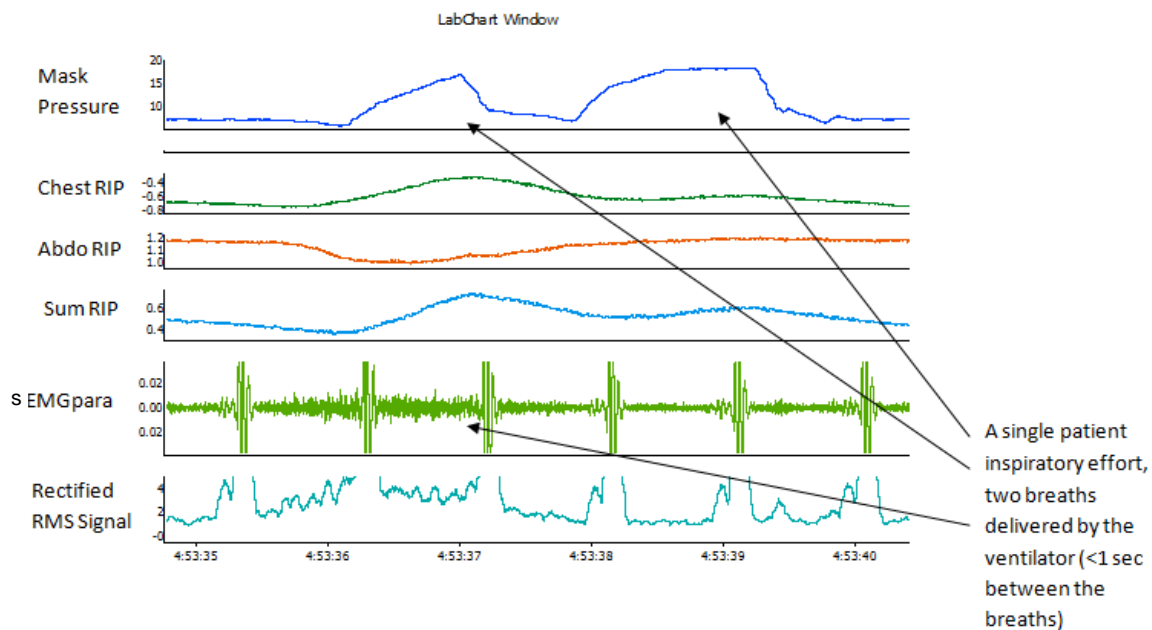


*Abbreviations:* Chest RIP- chest wall respiratory inductance plethysmography, Abdo RIP- abdominal wall respiratory inductance plethysmography, Sum RIP- Sum of both the chest wall and abdominal inductance plethysmography bands, sEMGpara- surface second intercostal parasternal electromyography signal, Rectified RMS Signal- rectified root mean square of the parasternal electromyography signal, Ti-inspiratory time, PSV-pressure support ventilation delivered breath.

### 2.9.3 Defining double triggering

Double triggering is an asynchronous event where a patient demands a single breath but 2 breaths are delivered by the ventilator. We defined double triggering as 2 breathing cycles of the ventilator delivered separated by a short expiratory time (defined as up to 1 second). The first cycle must be patient triggered, the second cycle is not. (Figure 24).(79)

**Figure 23: A representative trace of a 'double triggering' asynchronous event**

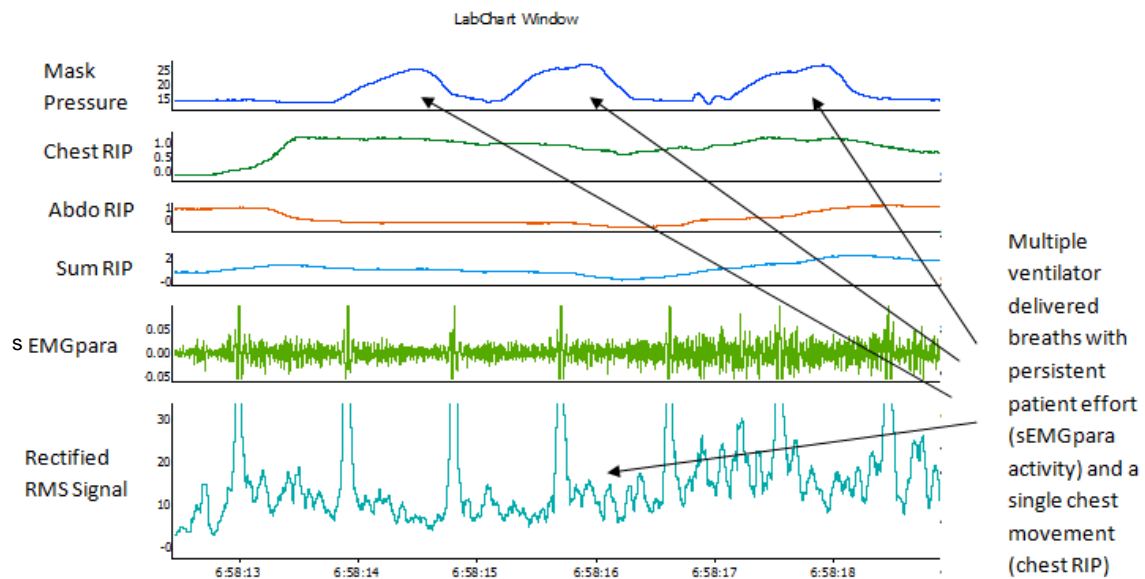


*Abbreviations:* Chest RIP- chest wall respiratory inductance plethysmography, Abdo RIP- abdominal wall respiratory inductance plethysmography, Sum RIP- Sum of both the chest wall and abdominal inductance plethysmography bands, sEMGpara- surface second intercostal parasternal electromyography signal, Rectified RMS Signal- rectified root mean square of the parasternal electromyography signal.

#### 2.9.4 Defining multiple triggering

Multiple triggering is an asynchronous event where a patient makes a single continuous demand for a breath that triggers multiple breaths from the ventilator. This requires sEMGpara activity representing neural respiratory drive to be continuously present throughout all the delivered breaths. A single movement of the respiratory inductance plethysmography bands is seen. (Figure 25).(79)

**Figure 24: A representative trace of a 'multiple triggering' asynchronous event**



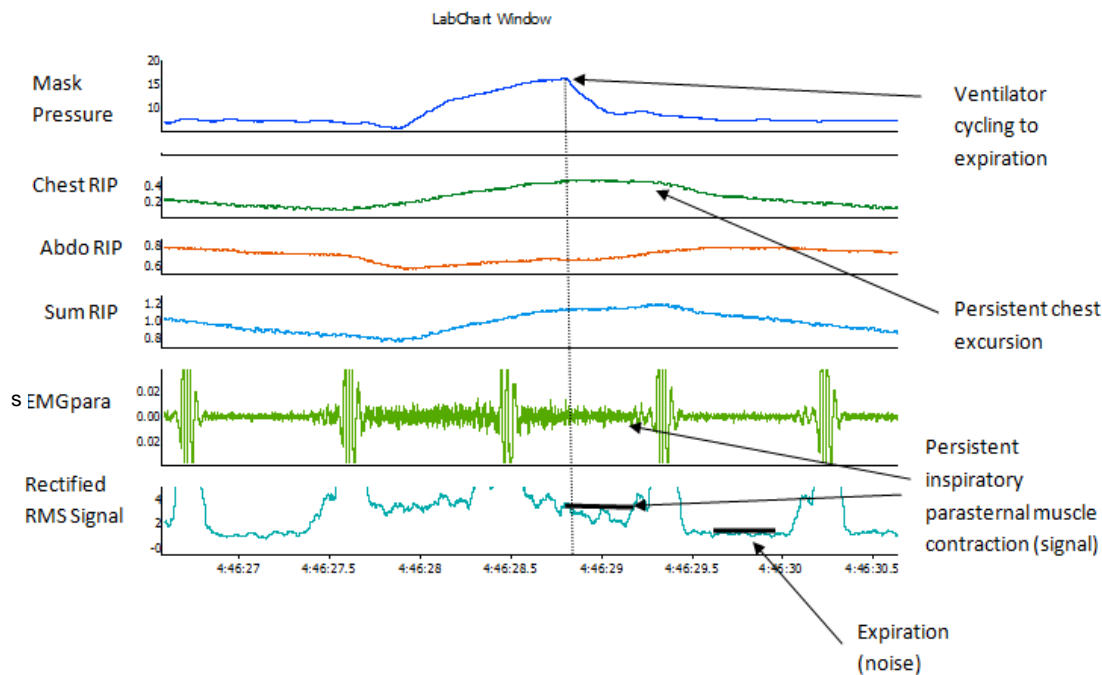
*Abbreviations:* Chest RIP- chest wall respiratory inductance plethysmography, Abdo RIP- abdominal wall respiratory inductance plethysmography, Sum RIP- Sum of both the chest wall and abdominal inductance plethysmography bands, sEMGpara- surface second intercostal parasternal electromyography signal, Rectified RMS Signal- rectified root mean square of the parasternal electromyography signal.

### 2.9.5 Defining premature expiratory cycling asynchrony

Premature expiratory cycling represents a patient ventilator asynchronous event, the patient's neural inspiratory time continues whilst the ventilator cycles into expiration. (Figure 26). To identify this from our traces we have defined it as occurring when the following rules are present:

1. The ventilator cycles to expiration seen by a reduction in the pressure signal towards the baseline whilst sEMGpara activity continues.
2. Thoraco-abdominal band movement continue outwards in the direction of inspiration whilst the ventilator cycles into expiration. (79)

**Figure 25: A representative trace of a 'premature expiratory cycling' asynchronous event**



*Abbreviations:* Chest RIP- chest wall respiratory inductance plethysmography, Abdo RIP- abdominal wall respiratory inductance plethysmography, Sum RIP- Sum of both the chest wall and abdominal inductance plethysmography bands, sEMGpara- second intercostal parasternal electromyography signal, Rectified RMS Signal- rectified root mean square of the parasternal electromyography signal.

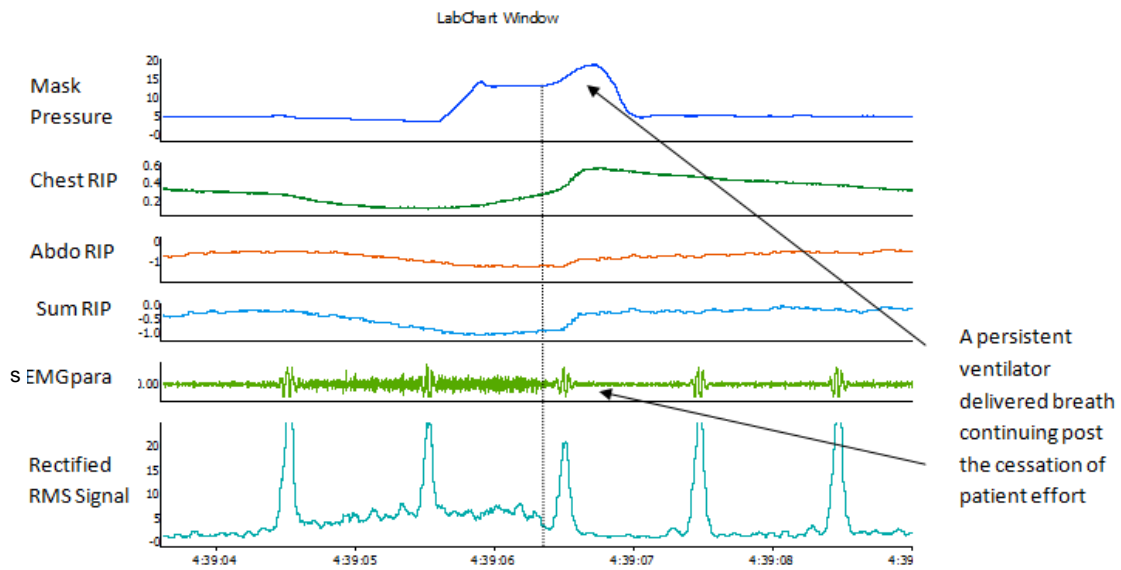
### 2.9.6 Defining extended expiratory cycling asynchrony

Extended expiratory cycling represents the patient's neural inspiratory time finishing but the ventilator remains in inspiration i.e. the patient tries to expire but the ventilator continues to give an inspiratory support breath. (Figure 27). We have defined this as being present with the following rules:

1. sEMGpara activity stops 20ms prior to the expiratory phase
2. A small increase in the pressure wave may be seen, representing the patient trying to forcibly expire i.e. 'fighting the ongoing inspiratory manoeuvre'.
3. Abdominal EMG signal may be visible indicating forced expiratory muscle recruitment.

1 must be present. 2 and 3 may be present to assist identification but are not mandatory. (79)

**Figure 26: A representative trace of a ‘delayed expiratory cycling’ asynchronous event**

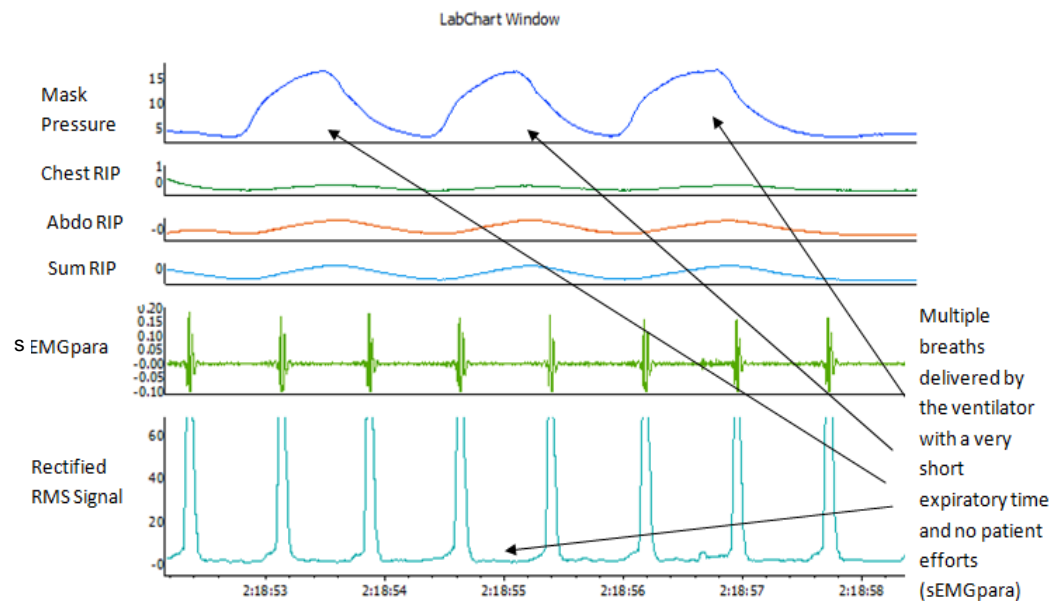


*Abbreviations:* Chest RIP- chest wall respiratory inductance plethysmography, Abdo RIP- abdominal wall respiratory inductance plethysmography, Sum RIP- Sum of both the chest wall and abdominal inductance plethysmography bands, sEMGpara- surface second intercostal parasternal electromyography signal, Rectified RMS Signal- rectified root mean square of the parasternal electromyography signal.

### 2.9.7 Defining autocycling

Autocycling is defined as multiple cycles of ventilator breaths being delivered in quick succession. More than 2 breaths must be delivered each separated by a short expiratory time of less than 1 second. These breaths are not triggered by the patient but occasionally sEMGpara activity is seen in association as the patient may attempt to co-ordinate with the ventilator. (Figure 28). (79)

**Figure 27: A representative trace of an ‘autocycling’ asynchronous event**



*Abbreviations:* Chest RIP- chest wall respiratory inductance plethysmography, Abdo RIP- abdominal wall respiratory inductance plethysmography, Sum RIP- Sum of both the chest wall and abdominal inductance plethysmography bands, sEMGpara- surface second intercostal parasternal electromyography signal, Rectified RMS Signal- rectified root mean square of the parasternal electromyography signal.

## 2.10 Inter-rater reliability in detection on patient ventilator asynchrony

Two assessors (MR and SM) were blinded and independently scored 10 randomly selected one hour sections of recorded data from 10 patients. Asynchronous events were manually assessed according to the a priori definitions. (Figures 22-28).

10 patients (4 COPD, 4 ORRF, 2 NMD-CWD) were included in this sub-study. A total of 4,603 breaths were analysed by two independent scorers with PVA reported in 812 (35%) and 891 (39%) breaths, respectively. The Inter class correlation coefficient (ICC) between the scorers was 0.84 (0.74-0.90). The predominant asynchrony reported was ineffective efforts, for which there was the closest inter-observer agreement with an ICC of 0.94 (0.79-0.99). The agreement for triggering and cycling PVA are shown in Table 6 and Table 7. The lowest agreement was observed in the autocycling asynchrony (0.22; -0.54-0.74), albeit this had a very low frequency and was observed in <1% of the total breaths analysed. (79)

**Table 6 Agreement of triggering asynchrony between 2 independent scorers**

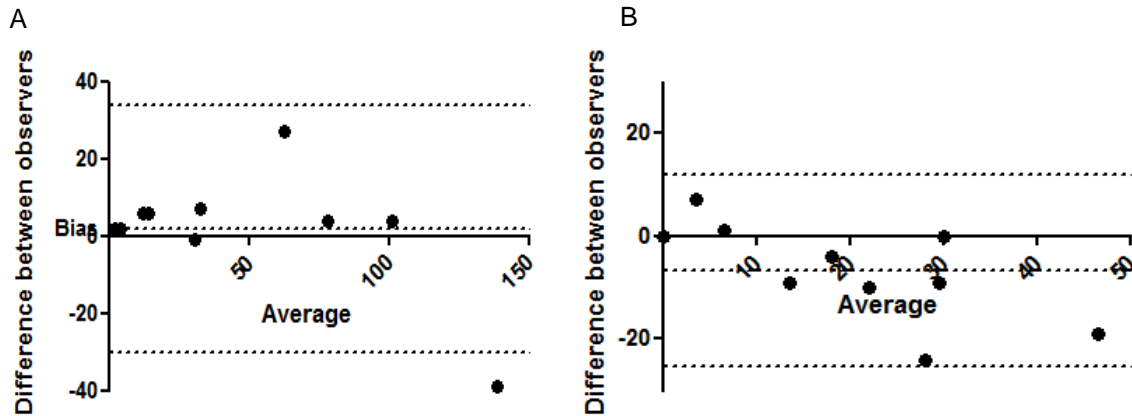
Type of Asynchrony	Scorer 1 n (% breaths)	Scorer 2 n (% breaths)	ICC (95% CI)	Bland- Altman Analysis Bias (95% Limits of Agreement)
Ineffective effort	484 (21%)	466 (21%)	0.94 (0.79-0.99)	1.8 (-30.1, 33.7)
Auto-triggering	164 (7%)	231 (10%)	0.77 (0.19-0.94)	-6.7 (-25.4, 12.0)
Double Triggering	22 (<1%)	11 (<1%)	0.67 (0.11-0.91)	1.1 (-1.9, 4.1)
Multiple Triggering	4 (<1%)	4 (<1%)	1.00	0.0 (0.0, 0.0)

**Table 7 Agreement of cycling asynchrony between 2 scorers**

Type of Asynchrony	Scorer 1 n (% breaths)	Scorer 2 n (% breaths)	ICC (95% CI)	Bland- Altman Analysis Bias (95% Limits of Agreement)
Premature Cycling	88 (4%)	124 (5%)	0.73 (0.26-0.92)	-3.6 (-18.7, 11.5)
Extended Cycling	45 (2%)	50 (2%)	0.76 (0.31-0.93)	-0.5 (-8.6, 7.6)
Auto-cycling	5 (<1%)	5 (<1%)	0.22 (-0.54-0.74)	0.0 (-2.3, 2.3)

A total of 4603 breaths were analysed with patient ventilator asynchrony reported in 812 and 891 breaths by scorer 1 and scorer 2, respectively. *Abbreviations:* ICC= intra-class correlation coefficient, CI=confidence interval.

**Figure 28: Bland-Altman comparison of (A) Ineffective efforts and (B) Auto-triggering asynchrony**



PVA can be reliably identified using the above technique. The predominant PVA's were ineffective efforts for which there was the greatest agreement. This analysis could be automated to provide a simple approach to assessing PVA.

### 2.10.1 Scoring PVA in association with sleep and wakefulness during the overnight study

I took a pragmatic approach to scoring events during our overnight analysis and comparing these with the polysomnography data. Both the respiratory polygraphy data and the overnight polysomnography were synchronised and analysed as 2 minutes every 10 minutes of data, excluding movement artefacts. The terms used to describe the events analysed were described as follows.

PVA is defined and reported throughout this thesis as the percentage of breaths out the total breaths analysed that demonstrated PVA, including type of asynchrony, unless stated otherwise.  $PVA_{wake}$  was defined as the total number of PVA observed per hour during periods of wake during the overnight analysis.  $PVA_{sleep}$  was defined as the total number of asynchronous events observed per hour during periods of sleep as determined by PSG.

The arousal index ( $AI_{psg}$ ) was defined as the number of EEG identified arousals from sleep lasting > 3 seconds that occurred per hour from the complete PSG analysis. The arousal index ( $AI_{total}$ ) was defined as the calculated arousal index per hour, this was targeted on the detailed 2 minute epochs that were examined for PVA throughout the overnight study. The patient-ventilator asynchrony arousal index ( $AI_{pva}$ ) was defined as the number of patient ventilator asynchronous events that

preceded an arousal within 3 seconds per hour of sleep overnight calculated from the 2 minute epoch assessments,

### **2.10.2 Acquisition and storage of Data**

All data acquisition took place in the Lane Fox Unit, St. Thomas' Hospital, London. The data were anonymised, stored and analysed in the Lane Fox Unit, in locked rooms when unoccupied on password protected laptops (HP Inc UK Limited, Bracknell, Berks, UK).

### **2.10.3 Statistical Analysis**

Anthropometric data, were normally distributed and are presented as mean and standard deviation (SD). Unpaired t-tests were used to compare baseline characteristics between both the patient groups and; patient and healthy subjects. A one way analysis of variance (ANOVA) with a Dunn's multiple comparisons correction test were performed to compare baseline characteristics between the disease groups and identify where significant differences occurred.

All other data were non-parametric and are presented as median value with the inter-quartile range. Comparisons between the sEMGpara signals in different postures were performed using an ANOVA. Whereas comparisons between healthy subjects and Duchenne Muscular Dystrophy (DMD) patients in Chapter 3 used Mann-Whitney U t-test analysis. Spearman correlation was applied to assess the relationship between changes in sEMGpara%max and EMGdi%max in different postures. The same correlations were used to assess the sEMGpara%max and measures of spirometry or body mass index in DMD patients.

Similar comparisons between the physician led set up and the physiological led set up in Chapter 4 were also performed using a Mann-Whitney U t-test. Comparisons between the disease groups were performed using a Kruskal-Wallis test with a Dunn's multiple comparison correction test. To assess changes in outcome measures over time in either the ventilator set up groups or the disease groups a repeated measures Friedman test was applied. Correlations between PVAs and outcomes measures were performed with a Spearman correlation.

In chapter 5, sleep quality measures were compared over time with the Wilcoxon-matched pairs test. Comparisons of PVA levels in the same patient between different sleep stages were performed with a repeated measures Friedman test. The frequency of PVAs occurring in different sleep levels and leading to arousals were compared using a Kruskal-Wallis test with a Dunn's multiple comparison correction test. Correlations between PVAs and sleep efficiency measures were again performed with a Spearman correlation.

Comparison of data between healthy subjects and COPD patients in Chapter 6 was performed using Mann-Whitney t-test. Spearman correlations were performed between trigger delay settings and participant outcome measures such as respiratory muscle loading or comfort scores.

To assess the inter-rater reliability of identifying PVA using our technique, described earlier in Methods section 1.10, intraclass correlation coefficient (ICC) was analysed. This was based on 2-way random effects model with absolute agreement to measure reliability. The agreement between each pair of observations was also assessed using Bland and Altman plots.

For all analyses, a p-value  $<0.05$  was considered statistically significant. Data analysis was performed using IBM SPSS Statistics v22 (IBM Corporation, Portsmouth, UK) and GraphPad Prism 6 software (GraphPad Software Inc, San Diego, CA, USA).

# **Chapter 3 The effect of posture on neural respiratory drive to parasternal intercostal and diaphragm muscles in healthy subjects and Duchenne Muscular Dystrophy patients**

## **3.1 Background**

Neural respiratory drive has previously been quantified by measuring diaphragm EMG (EMGdi) using a multi-pair oesophageal electrode reflecting the load and capacity balance of the respiratory system. EMGdi, measured continuously during sleep on a breath-by-breath basis, may be a useful method of monitoring respiratory disease severity and the effect of mechanical ventilation.(125, 128) In the upright position, the rib cage expands more than the abdomen whereas in the supine position, most normal healthy subjects are 'abdominal breathers'.(129) During resting tidal breathing normal healthy subjects have shown greater activation of the rib cage inspiratory muscles and of the diaphragm in an upright posture compared to a supine posture.(130) The increased electrical activity of the diaphragm in the upright position is considered a mechanism for counterbalancing the adverse effects produced by the upright posture on the length-tension state of the diaphragm and facilitates the generation of a constant transdiaphragmatic pressure.(129) sEMGpara is usually acquired seated in a 45 degree position but has been previously used to assess neural respiratory drive in both asthmatics and healthy controls overnight.(124, 125) If sEMGpara is to be used to continuously monitor the respiratory system it is important for the operator to be understand the effect of posture on the signal acquisition in health subjects which is the focus of the first part of the study. The second part of this study was to ensure that sEMGpara could be measured in patients with Duchenne muscular dystrophy, where the signal size may be affected both by posture as well as the underlying muscle wasting disease process preventing recruitment of the chest wall inspiratory muscles.

**3.1.1 Study hypothesis: There is a change in neural respiratory drive accompanying changes in body position from 45° upright.**

## 3.2 Material and Methods

Healthy subjects and Duchenne Muscular dystrophy patients were recruited for this study to validate sEMGpara acquisition in different postures.

### Baseline data

Following enrolment, healthy subjects performed spirometry to exclude significant underlying obstructive or restrictive lung disease. Height and weight measurements were also performed to calculate body mass index. Duchenne muscular dystrophy patients also performed spirometry to characterise the severity of their restrictive deficit. The weight in these patients was similarly recorded on weighing scales, height was estimated by measuring the arm span to calculate the body mass index.

### sEMGpara Measurement

Five different postures were examined; 45 degrees, 90 degrees upright, flat horizontal, lying on the right hand side and lying on the left hand side. The sequence of the positions was randomised between subjects. sEMGpara measurements were obtained during tidal breathing with the subject fully supported by the bed in each different posture to minimise signal artefact. sEMGpara was measured during two minutes of tidal breathing post 10 minutes of relaxed breathing in each posture. Resting sEMGpara was normalised to the maximal inspiratory manoeuvre performed in each position (sEMGpara%max) as described in the Material and Methods section 1.7.1.

### Data and Statistical Analysis

Baseline characteristics are expressed as mean ( $\pm$  standard deviation (SD)). sEMGpara tabulated data are expressed as median and interquartile range unless otherwise stated. sEMGpara data are expressed as median, interquartile range and total range in all figures. The sEMGpara data were not normally distributed as defined by the Kolmogorov-Smirnov test and so non-parametric tests were applied. Differences in sEMGpara%max between the standardised 45 degree position and different postures were analysed using a Kruskal-Wallis One-Way ANOVA test with a Dunns correction to compare all data points. Bland-Altman tests were used to compare sEMGpara and EMGdi results and a spearman correlation was used to compare the changes in both values with different postures. The

neural drive of Duchenne Muscular dystrophy patients and healthy controls were compared using Mann-Whitney t-tests. Spearman correlation was used to correlate measures of sEMGpara%max with spirometry values and body mass index results. A p-value <0.05 was considered as statistically significant.

### **3.3 Results**

#### **3.3.1 Subject demographics**

Seventeen healthy subjects were recruited (12 female). Mean (SD) age was 39 ( $\pm 13$ ) years with a mean body mass index (SD) of 23.0 ( $\pm 3.5$ )kg/m<sup>2</sup>. The mean FEV<sub>1</sub> predicted (SD) was 99 ( $\pm 13$ )% and FVC predicted (SD) was 106 ( $\pm 21$ )% consistent with normal spirometric values. Phasic inspiratory neural drive was reliably recorded in all postures for 11 healthy subjects (65%). Adequate inspiratory sEMGpara signal was demonstrated in the right and left lateral postures in 12(71%) subjects. The inspiratory sEMGpara signal was inadequate in the flat posture in 2(12%) subjects. There was no statistical difference in the baseline characteristics between those healthy subjects that had adequate sEMGpara recorded in all 5 postures and those who did not; to account for this (Table 8).

Five healthy subjects (3 females) consented to simultaneous EMGdi measurements of which four (3 females) subjects demonstrated an adequate sEMGpara signal in all 5 postures. Mean (SD) age was 40 ( $\pm 11$ ) years with a mean body mass index (SD) of 23.0 ( $\pm 3.4$ )kg/m<sup>2</sup>. The mean FEV1 predicted (SD) was 104 ( $\pm 9$ )% and FVC predicted (SD) was 117 ( $\pm 8$ )% consistent with normal spirometric values.

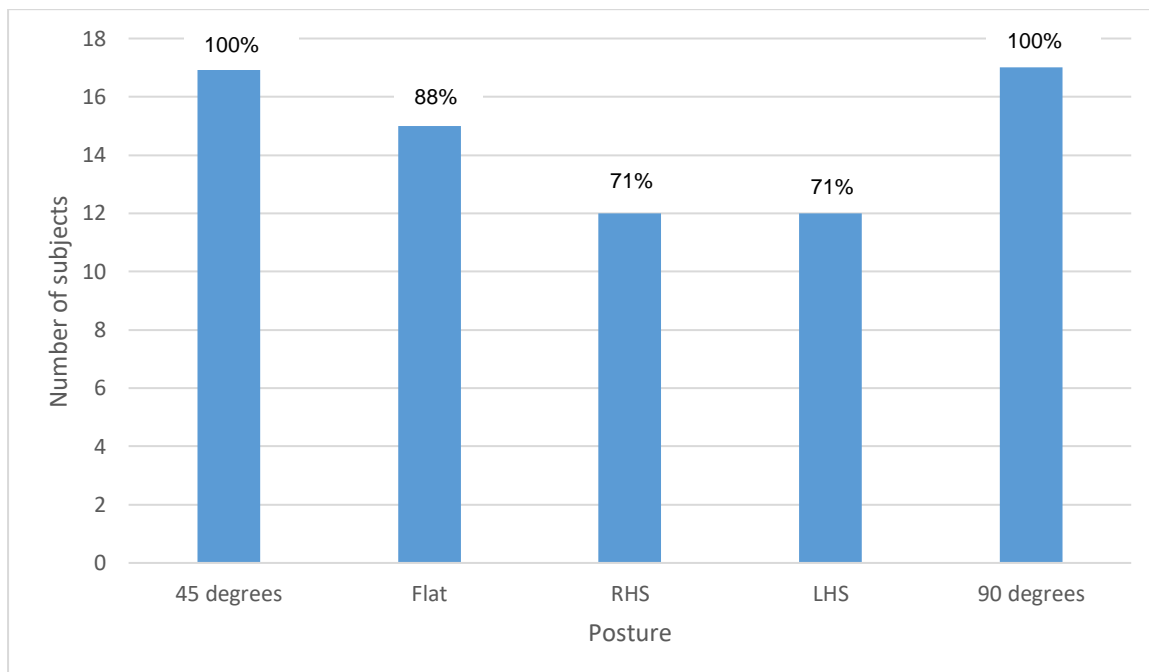
Four Duchenne muscular Dystrophy patients (all male) were also studied to confirm that an sEMGpara signal was obtainable in the 5 different postures. Mean (SD) age was 26 ( $\pm 2$ ) years with a mean body mass index (SD) of 20.0 ( $\pm 2.4$ )kg/m<sup>2</sup>. The mean FEV1 predicted (SD) was 16 ( $\pm 4$ )% and FVC predicted (SD) was 15 ( $\pm 3$ )% consistent with restrictive spirometric values. Duchenne patients as expected were younger with a lower BMI and restrictive spirometry values compared to healthy controls.

**Table 8: Healthy subjects demographics for the total enrolled and for those with adequate signal in all 5 postures**

Subject Characteristics	Total group (n=17)	Adequate signal acquisition (n=11)	p-value
Age (yrs)	39 ( $\pm$ 13)	40 ( $\pm$ 14)	0.9
BMI (kg/m <sup>2</sup> )	23 ( $\pm$ 4)	24 ( $\pm$ 4)	0.6
FEV1 (%pdt)	99 ( $\pm$ 13)	103 ( $\pm$ 14)	0.5
FVC (%pdt)	106 ( $\pm$ 21)	112 ( $\pm$ 24)	0.5
FEV1/FVC (%)	80 ( $\pm$ 7)	79 ( $\pm$ 7)	0.6

*Abbreviations:* yrs-years, BMI- body mass index, FEV1-forced expiratory volume in 1 second, FVC-forced vital capacity

**Figure 29: The proportion of patients in whom an adequate phasic inspiratory sEMGpara signal was detected in each posture**



*Abbreviations:* RHS- right hand side, LHS-left hand side

### 3.3.2 sEMGpara measurements in healthy subjects

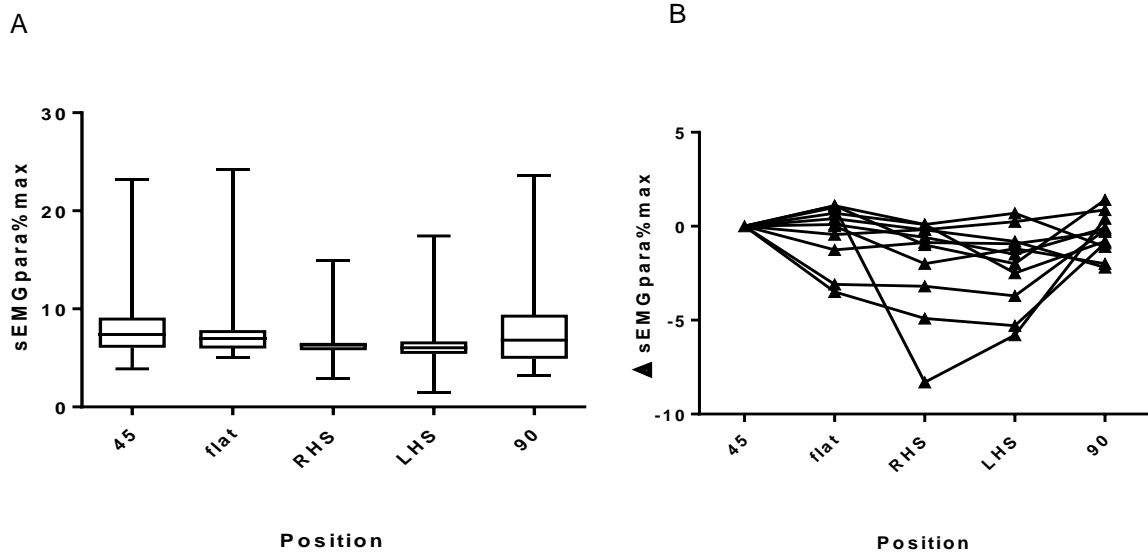
Excluding the sEMGpara signals where clear phasic inspiratory activity was not seen in all postures 11 subjects' data were amenable to analysis. sEMGpara%max was statistically significantly lower in the right and left lateral positions, the median sEMGpara%max difference was -0.9% (-3.2 to -0.2) and -1.5% (-3.7 to -0.8) respectively. No statistically significant difference was seen between the sEMGpara%max signals in the 90 degree upright position and lying flat compared to the standardised 45 degree position.

**Table 9: sEMGpara%max signals obtained in the 5 different postures including the change from the standardised 45 degree posture**

Subject	45 degrees,%	Flat,% (change from 45 degrees)	RHS,% (change from 45 degrees)	LHS,% (change from 45 degrees)	90 degrees,% (change from 45 degrees)
1	6.6	7.0 (0.4)	6.4 (-0.2)	5.8 (-0.8)	4.4 (-2.2)
2	3.9	5.0 (1.1)	2.9 (-1.0)	1.9 (-2.0)	5.3 (1.4)
3	4.0	5.1 (1.1)	4.1 (0.1)	1.5 (-2.5)	3.2 (-0.8)
4	6.9	7.0 (0.1)	6.3 (-0.6)	5.4 (-1.5)	6.8 (-0.1)
5	23.2	24.2 (1.0)	14.9 (-8.3)	17.4 (-5.8)	23.6 (0.4)
6	7.8	7.8 (0.0)	5.8 (-2.0)	6.6 (-1.2)	5.8 (-2.0)
7	11.3	7.8 (-3.5)	6.4 (-4.9)	6.0 (-5.3)	10.4 (-0.9)
8	6.0	6.7 (0.7)	6.1 (0.1)	6.7 (0.7)	4.9 (-1.1)
9	9.1	6.0 (-3.1)	5.9 (-3.2)	5.4 (-3.7)	8.9 (-0.2)
10	7.4	6.1 (-1.3)	6.5 (-0.9)	6.5 (-0.9)	7.1 (-0.3)
11	9.5	8.1 (-0.4)	8.4 (-0.2)	8.8 (0.2)	9.4 (0.9)
Median (IQR)	7.4 (6.0-9.1)	7.0 (6.0-7.8)	6.3 (5.8-6.5)	6.0 (5.4-6.7)	6.8 (4.9-9.4)

*Abbreviations:* 45- sitting at a 45 degree posture, flat-lying flat on the back RHS- lying on the right hand side, LHS- lying on the left hand side, 90- sitting at a 90 degree posture.

**Figure 30: Change in sEMGpara%max with 5 different postures A) Actual sEMGpara%max measurements B) change in sEMGpara%max from 45 degree position (gold standard)**



*Abbreviations:* 45- sitting at a 45 degree posture, flat-lying flat on the back RHS- lying on the right hand side, LHS- lying on the left hand side, 90- sitting at a 90 degree posture, sEMGpara%max-normalised surface parasternal electromyogram reading to a maximal inspiratory manoeuvre.

It was observed that the sEMGpara%max signal reliability was frequently related to the signal amplitude, with smaller signals more prone to difficulties in detecting a physiological signal above a noise signal in the different postures. The sEMGpara%max signal amplitude between subjects that were interpretable across all the 5 postures and those that were non-interpretable were compared. A significant reduction in signal amplitude was noted in the non-interpretable sEMGpara%max group ( $p=0.002$ ).

**Table 10: Comparison between baseline sEMGpara%max signals obtained at 45 degrees in healthy subjects that had reproducible and non-reproducible signals in all 5 postures studied.**

Subjects	Reproducible sEMGpara%max (%)	Non-reproducible sEMGpara%max (%)
1	6.6	1.8
2	3.9	4.3
3	4.0	2.7
4	6.9	4.1
5	23.2	3.9
6	7.8	3.4
7	11.3	
8	6.0	
9	9.1	
10	7.4	
11	8.5	
Median (IQR)	7.4 (6.0-9.1)	3.7 (2.5-4.2)

*Abbreviations:* sEMGpara%max- surface second intercostal parasternal signal normalised to a maximal inspiratory manoeuvre.

### 3.3.3 EMGdi signal measurement in healthy subjects

Concurrent EMGdi was measured in 5 healthy subjects (3 females). A phasic inspiratory signal was obtained in all individuals in the 5 postures examined. To compare the subjects EMGdi was recorded as a percentage of a maximal inspiratory manoeuvre (EMGdi%max) either a SNIP or MIP whichever provided the greater EMGdi recruitment. Comparing the EMGdi%max signal obtained in the 5 different postures using a Friedman repeated measures test, no significant difference was observed

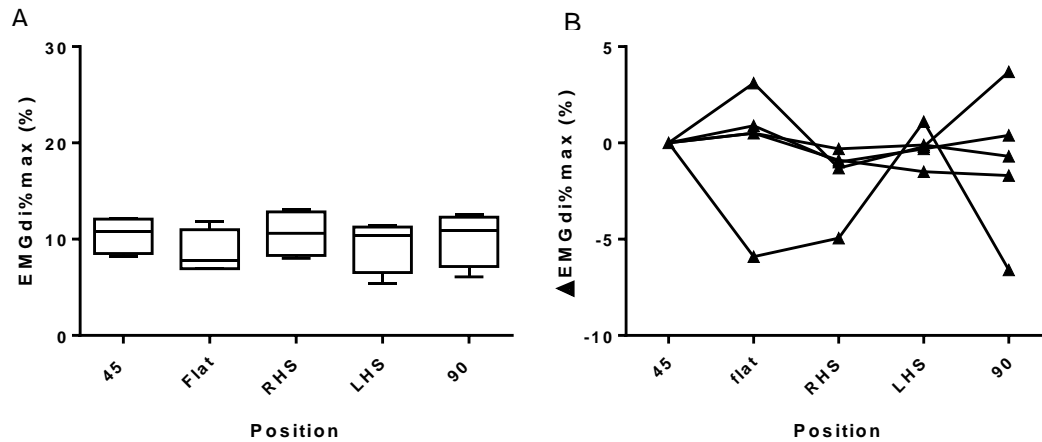
between the different postures ( $p=0.17$ ). The lowest median EMGdi%max value was recorded in the supine posture however there were very variable responses to the different postures between two individuals in this study (Figure 32).(129)

**Table 11: EMGdi%max signals obtained in the 5 different postures in healthy subjects including the change from the standardised 45 degree posture**

Subject	45 degrees, %	Flat,% (change from 45 degrees)	RHS, % (change from 45 degrees)	LHS, % (change from 45 degrees)	90 degrees, % (change from 45 degrees)
1	8.2	6.9 (-1.3)	8.0 (-0.2)	11.9 (3.7)	11.3 (3.1)
2	9.5	8.5 (-1.0)	9.2 (-0.3)	9.9 (0.4)	10.4 (0.9)
3	12.0	7.1 (-4.9)	13.1 (1.1)	5.4 (-6.6)	6.1 (-5.9)
4	9.3	8.4 (-0.9)	7.8 (-1.5)	7.6 (-1.7)	9.8 (0.5)
5	12.1	11.8 (-0.3)	12.0 (-0.1)	11.4 (-0.7)	12.6 (0.5)
Median (IQR)	9.5 (8.8-12.1)	8.4 (7.0-10.2)	9.2 (7.9-12.6)	9.9 (6.5-11.7)	10.4 (8.0-12.0)

*Abbreviations:* 45- sitting at a 45 degree posture, flat-lying flat on the back RHS- lying on the right hand side, LHS- lying on the left hand side, 90- sitting at a 90 degree posture,

**Figure 31: Change in EMGdi%max in healthy subjects with 5 different postures A) Actual EMGdi%max measurements B) change in EMGdi%max from 45 degree position -gold standard**

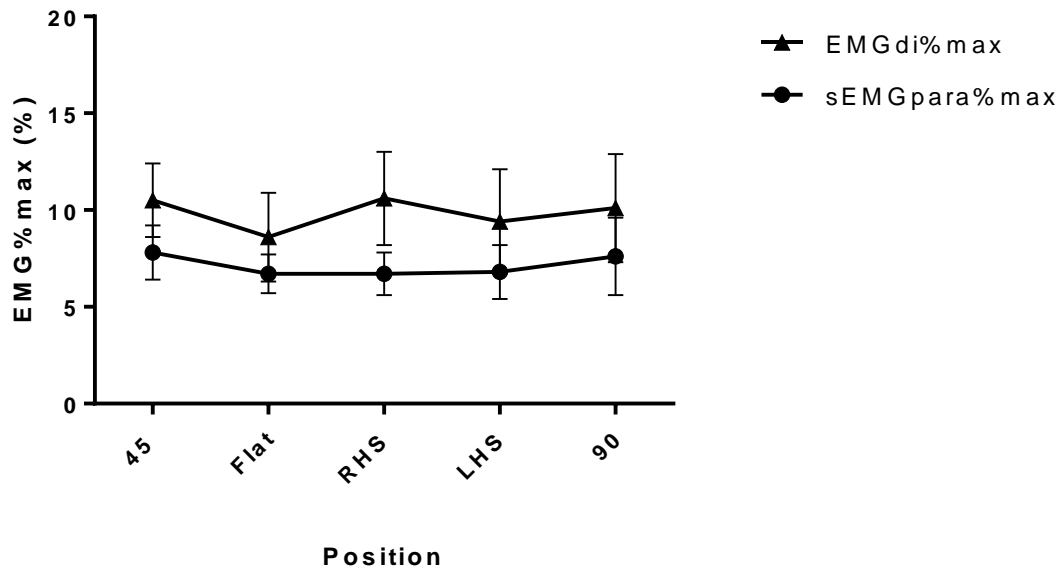


Graph A) data are represented by Box-whisker plots demonstrating median, IQR and minimum-maximum values. *Abbreviations:* 45- sitting at a 45 degree posture, flat-lying flat on the back RHS- lying on the right hand side, LHS- lying on the left hand side, 90- sitting at a 90 degree posture, sEMGpara%max- normalised parasternal electromyogram reading to a maximal inspiratory manoeuvre.

### 3.3.4 Comparison between sEMGpara%max and EMGdi%max in healthy subjects

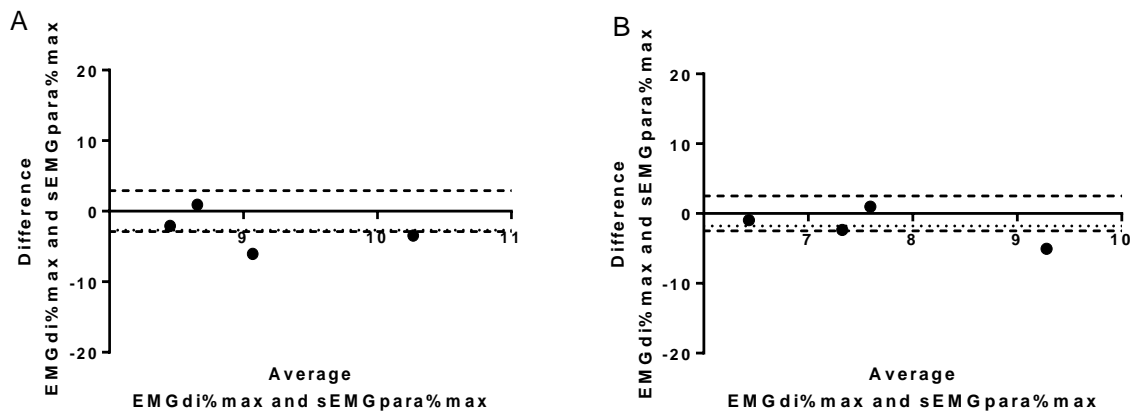
4 healthy subjects had reproducible EMGdi%max and sEMGpara%max recorded simultaneously. In all postures examined there was no statistically significant difference between the EMGdi%max and the sEMGpara%max obtained in these healthy subjects. Although as described previously, EMGdi%max was consistently a higher than sEMGpara%max (Figure 33).(131) The values obtained for both sEMGpara%max and EMGdi%max were similar to those previously published for healthy subjects. (127, 131, 132).

**Figure 32: Comparison between EMGdi%max and sEMGpara%max obtained in 4 healthy individuals during 5 different postures (45 degrees semi-recumbent, lying flat, lying on the right hand side, lying of the left hand side and sitting at 90 degrees).**



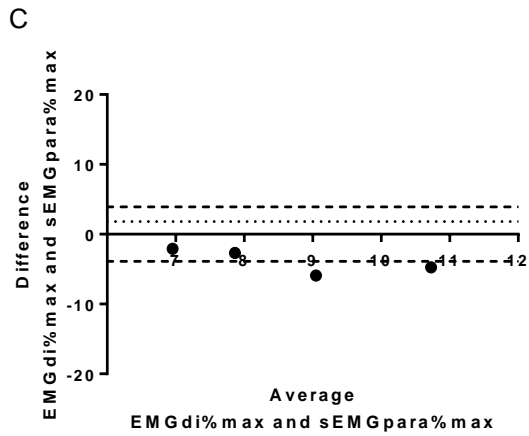
*Abbreviations:* 45- sitting at a 45 degree posture, flat-lying flat on the back RHS- lying on the right hand side, LHS- lying on the left hand side, 90- sitting at a 90 degree posture, sEMGpara%max-normalised parasternal electromyogram reading to a maximal inspiratory manoeuvre, EMGdi%max-normalised diaphragm electromyogram reading to a maximal inspiratory manoeuvre.

**Figure 33: Bland-Altman analysis of agreement between sEMGpara%max and EMGdi%max signals in all 5 postures in 4 healthy subjects (A-45 degrees semi-recumbent, B-flat, C-lateral right hand side, D-lateral left hand side, E-90 degrees sitting).**

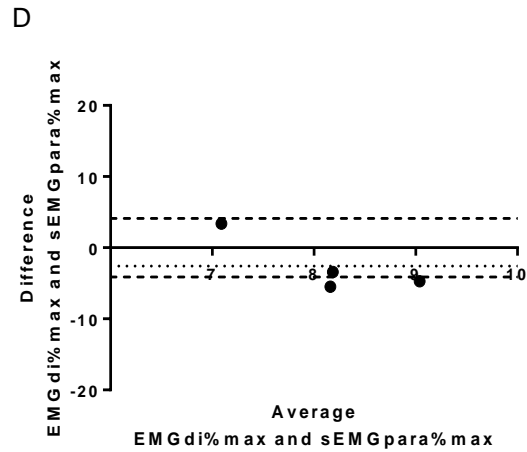


Graph A: bias-2.7%,SD of bias 2.9%,95% limits of agreement -8.4 to 3.0%

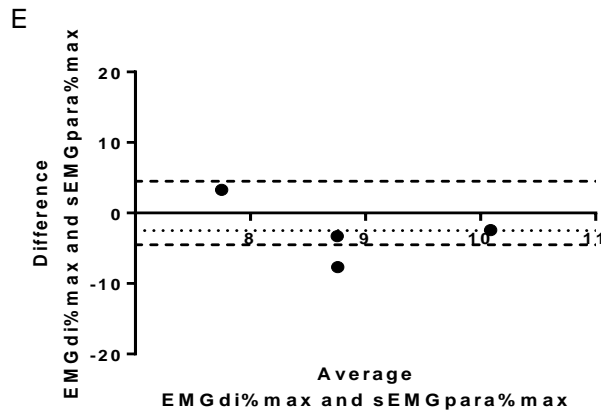
Graph B: bias-1.8%,SD of bias 2.5%,95% limits of agreement -6.8 to 3.1%



Graph C: bias-3.9%,SD of bias 1.8%,95% limits of agreement -7.3 to -0.4%



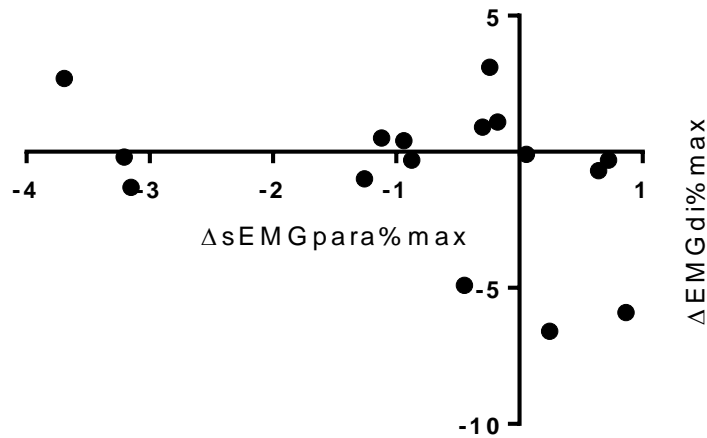
Graph D: bias-2.6%,SD of bias 4.1%,95% limits of agreement -10.5 to 5.4%



Graph E: bias-2.5%,SD of bias 4.5%,95% limits of agreement -11.4 to 6.3%

These data suggest that the value obtained from the sEMGpara%max is lower than that from EMGdi%max in all postures. No direct relationship was observed between the change in sEMGpara%max and EMGdi%max across the 5 postures, ( $r_s=-0.3$ ,  $p=0.28$ ). (Figure 35).

**Figure 34: Relationship observed between the change in sEMGpara%max and EMGdi%max from a standard (45 degree posture) across the 4 other postures.**



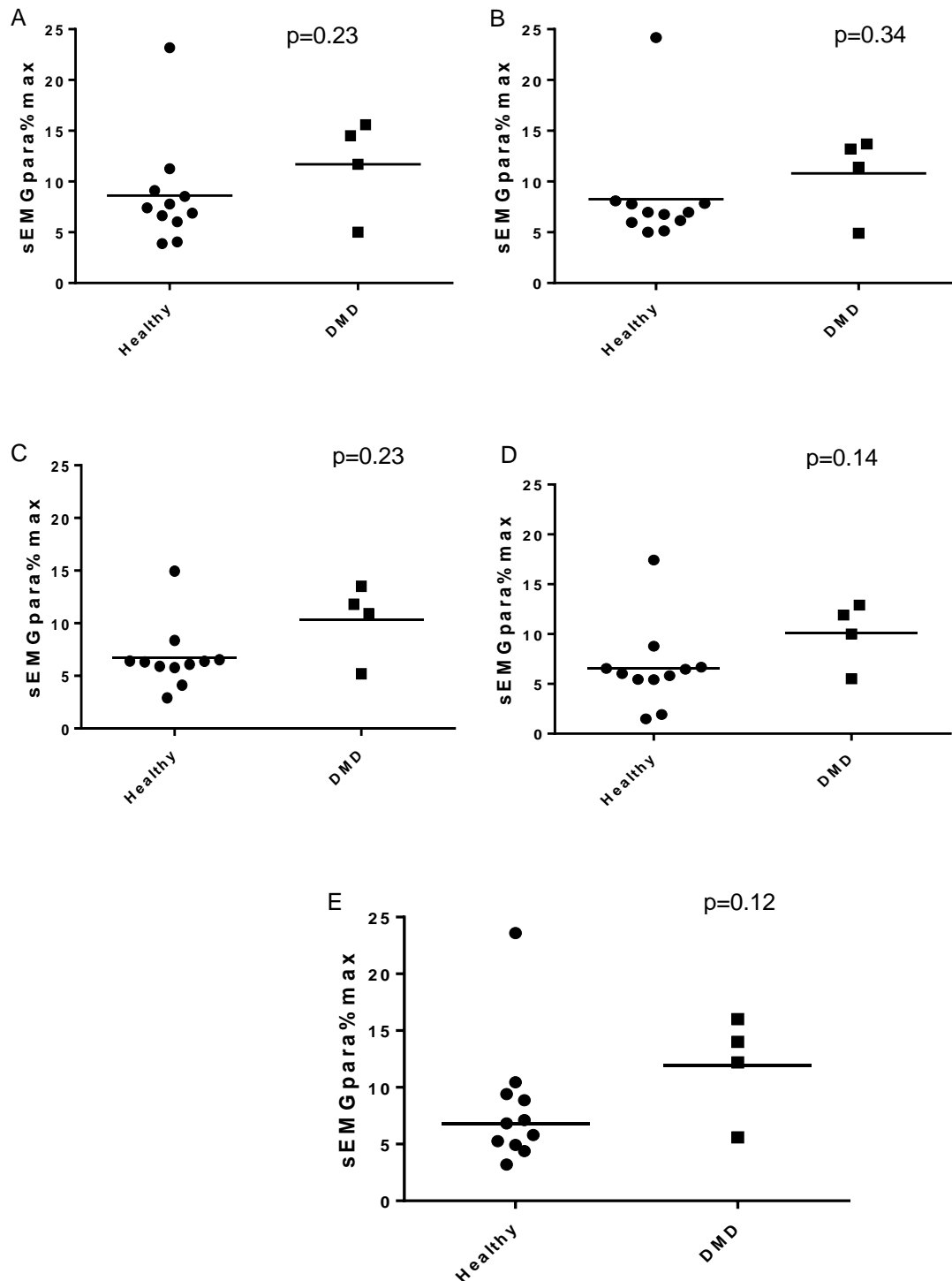
*Abbreviations:* sEMGpara%max- normalised surface parasternal electromyogram reading to a maximal inspiratory manoeuvre, EMGdi%max- normalised diaphragm electromyogram reading to a maximal inspiratory manoeuvre.

### 3.3.5 sEMGpara signals in Duchenne Muscular Dystrophy patients

Clear phasic inspiratory activity of sEMGpara signals was observed in all 4 patients analysed with Duchenne Muscular Dystrophy (DMD) in each of the 5 postures. The mean sEMGpara%max obtained was higher in DMD patients than healthy controls in all five postures but this did not reach statistical significance (Figure 36). No significant difference was seen in the sEMGpara%max obtained in any of the 5 postures in DMD patients ( $p=0.11$ ); Figure 37).

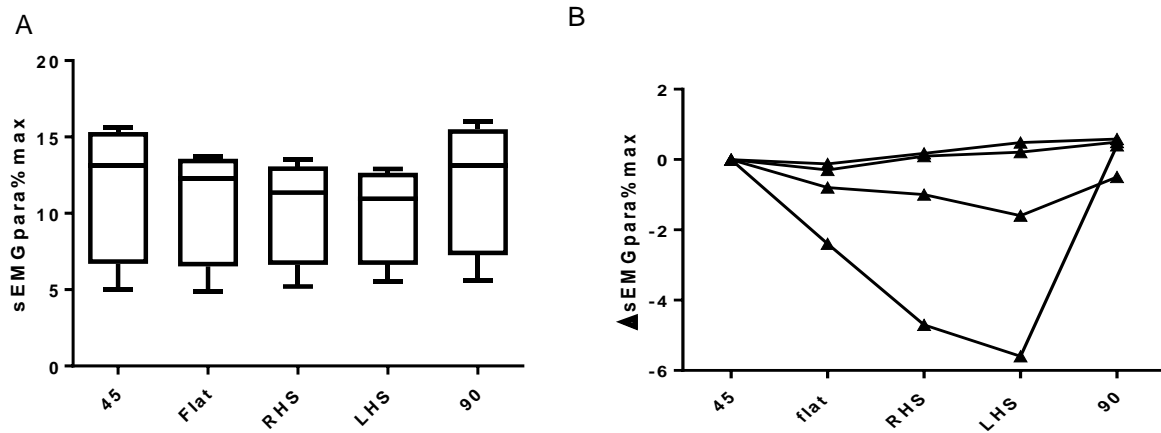
sEMGpara%max was not significantly correlated with age, BMI, FEV1% predicted or FVC% predicted (Figure 38) in these 4 DMD patients.

Figure 35: Neural respiratory drive measured by sEMGpara%max in A) 45 degrees (semi-recumbent) posture, B) Flat posture, C) Right hand side posture, D) Left hand side posture, E) 90 degree posture during tidal breathing in 11 healthy subjects and 4 Duchenne Muscular Dystrophy patients.



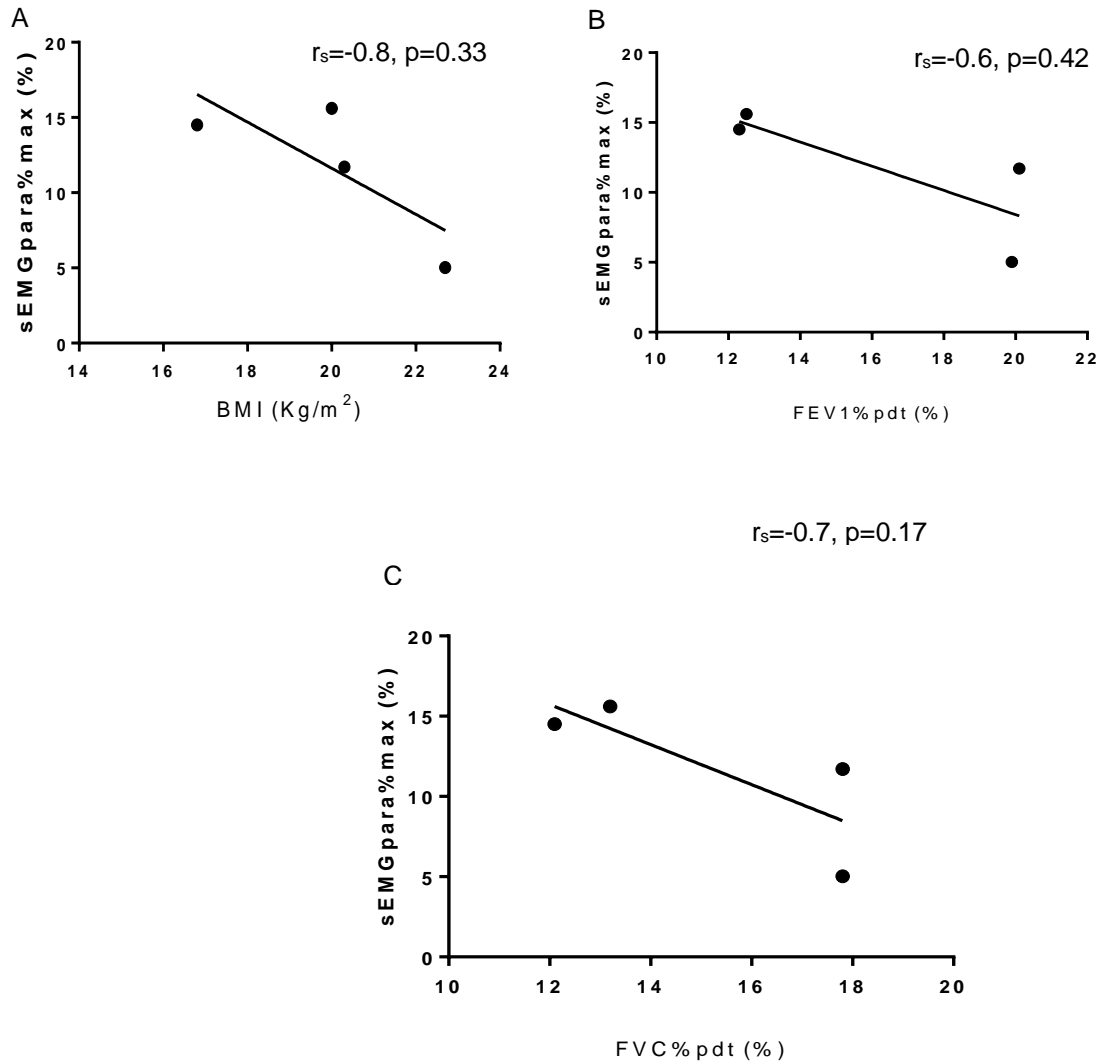
The horizontal bar delineates the median value for each group. *Abbreviations:* Healthy- healthy subjects, DMD- Duchenne muscular dystrophy patients, sEMGpara%max- normalised parasternal electromyogram reading to a maximal inspiratory manoeuvre.

**Figure 36: Changes in sEMGpara%max signals measured in Duchenne Muscular Dystrophy patients in 5 different postures**



A- Box and whisker plot representing the median sEMGpara%max and maximum and minimum values obtained in each of the 5 postures. B- Demonstrates the change in sEMGpara%max from the gold standard posture of 45 degrees in each of the 4 DMD subjects. *Abbreviations:* 45- sitting at a 45 degree posture, flat-lying flat on the back RHS- lying on the right hand side, LHS- lying on the left hand side, 90- sitting at a 90 degree posture, sEMGpara%max- normalised parasternal electromyogram reading to a maximal inspiratory manoeuvre.

**Figure 37: Relationships between sEMGpara%max and A) Body mass index (BMI), B) Forced expiratory volume in 1 sec percentage predicted (FEV1%pred), C) Forced Vital Capacity percentage predicted (FVC).**



*Abbreviations:* sEMGpara%max- normalised parasternal electromyogram reading to a maximal inspiratory manoeuvre, BMI-body mass index, FEV1-forced expiratory volume in 1 second, FVC-forced vital capacity.

## 3.4 Discussion

The sEMGpara%max signal was obtained in over 70% of healthy subjects recruited in all 5 postures. However, in a small proportion of healthy subjects with low levels of resting drive the signal was not analysable. sEMGpara%max did not significantly change between 45, 90 and lying flat in these subjects but there was a reduction observed in the signal obtained in the lateral postures.

Our study was concordant with previous values obtained in healthy subjects for EMGdi%max and sEMGpara%max and also demonstrated as previously observed that values for EMGdi%max were consistently greater than sEMGpara%max.(66, 127, 131, 132) EMGdi%max did not change significantly between the 5 different postures.

This is the first study to describe the levels of NRD in Duchenne Muscular Dystrophy patients quantified by sEMGpara%max demonstrating that it was both obtainable and reliably observed in all 5 postures. No significant difference in NRD was observed in these patients between the different postures although variation between individual responses was noted.

### 3.4.1 Critique of the method

The goal of this physiological study was to provide pilot data to demonstrate the feasibility and clinical utility of using sEMGpara as a continuous monitoring tool where different postures maybe adopted such as during sleep. The small number of participants that were monitored in the awake state may not represent the findings in a patient population that would be monitored clinically overnight.

The issues of surface EMG recording and contamination from other chest wall muscles are described.(30) Every attention was given to ensure good skin preparation and electrode placement was optimised but we found artefact to affect mainly the lateral postures. This is likely to be related to changes in the chest wall configuration, impedance of the skin and displacement of the electrode further away from the underlying parasternal muscle. Despite this, 88% of subjects had a reliable phasic inspiratory signal identified in all but lateral postures. Needle electrode technique could be used to isolate parasternal muscle activity but this is an invasive technique and would not be suitable for overnight monitoring.(121)

Examining the lack of statistical significant difference between the healthy subjects and the Duchenne muscular dystrophy patients it is observed that there is a clear outlier who consistently recruits more

than 15% of the maximum during tidal breathing in the different postures. When examining this individual further they are young at 27 years with a low BMI 19.4 although not the lowest in the cohort. Spirometry is within the normal range FEV<sub>1</sub> (90% predicted) and FVC (94% predicted). The raw EMG signal is similar to the other healthy subjects at 7.8 $\mu$ V, however, the maximal EMG signal is lower than the other healthy subjects at 34 $\mu$ V. Therefore the percentage of maximum muscle recruited during tidal breathing is higher. This highlights the difficulties with the EMG technique and the importance of familiarising subjects with the normalising techniques that have previously been discussed in the literature.(127) Despite making every effort to ensure that the SNIP was repeated at least 5 times, until three reproducible efforts with less than 10% variance were obtained as per the ATS/ERS guidelines (24), maximal inspiratory manoeuvres are non-the-less voluntary and so dependent upon the effort made by the subject.

We chose not to use the raw signal only as DMD patients are substantially weaker than healthy subjects as indicated by the intrinsic muscle wasting that occurs with this condition. The maximal raw EMG signal was significantly reduced in all DMD patients compared to healthy controls which is a true reflection of their underlying disease process (SNIP rawEMG at 45 degrees; healthy subjects 82 (60-114) $\mu$ V vs DMD patients 32 (15-40) $\mu$ V;  $p < 0.01$ ). The significance of their weakness is best expressed by the amount of muscle recruitment required for tidal breathing as a percentage of the maximum they can achieve, indicating the low reserve capacity available.

### **3.4.2 Significance of findings**

Importantly, neural respiratory drive (NRD), as measured by sEMGpara%max, does not significantly change on lying flat or sitting 90 degrees upright in healthy subjects. Neural respiratory drive falls when adopting the left hand side and right hand side postures. Caution should be taken to ensure that the sEMGpara%max signal is of adequate quality. If future automated monitoring were to be used a visual criterion with an appropriate signal to noise level would need to be set for an individual patient. sEMGpara%max can be considered as an overnight monitoring tool but attention must be paid to body position and combining sEMGpara%max and a body position accelerometer sensor would assist interpretation of the signal. Indeed, an automated system could exclude those

measurements that are acquired when the patient is lying on their side and aim to include all measurements in positions between 90 degrees and horizontally lying flat.

In this physiological study, we did not find a statistical difference between the changes in sEMGpara%max between the sitting and lying postures examined in either healthy or Duchenne muscular dystrophy patients. Furthermore, no difference was observed in the EMGdi%max of healthy subjects in any of the 5 postures, although I acknowledge that there was variability in the individual responses observed. Previous work has suggested in healthy subjects that the activation of the rib cage and diaphragm muscles is greater in the upright than in the supine position during tidal breathing.(130) However, under conditions of ventilatory stress evoked by CO<sub>2</sub> rebreathing the supine posture required higher activation of these muscles (129). Different proportions of ventilatory stress may have been experienced by healthy subjects due to subtle differences in their BMI and pulmonary mechanics. Work by Steier *et al.* has previously demonstrated that obese subjects have elevated neural respiratory drive which increases in a supine posture (66). Although the majority of our healthy controls had a BMI in a normal range, 5 participants would be categorised as overweight with a BMI between 25 kg/m<sup>2</sup> and 30kg/m<sup>2</sup>. Surface EMG may also be affected by underlying subcutaneous fat which may increase the distance between the electrode and the underlying parasternal intercostal muscle and this may change further with the body position adopted. Although every effort was made to ensure that skin preparation was optimal and the electrodes were seated correctly, this may explain some of the drop in the sEMGpara%max in the lateral posture in healthy subjects.

Our findings are concordant with previous studies indicating that NRD as measured by EMGdi%max in healthy subjects was between 8.4(±4.0)% and 10.0 (±7)%.(66, 131, 132) Similarly sEMGpara%max values observed in our study were comparable with previously work, sEMGpara%max values in healthy subjects were reported as 5.8 (±3)% and lower than the EMGdi%max values simultaneously recorded.(127) Unlike previous studies we did not demonstrate a strong correlation between the changes in EMGdi%max and sEMGpara%max in the 5 postures. However, the current study, unlike previous studies, investigated the effect of differing posture alone on neural respiratory drive rather than previous studies that have investigated both posture and external respiratory muscle loading. Although variability was observed, the majority of changes seen in the EMGdi%max measurements were less than 1% with only a single healthy subject

demonstrating more than a 5% change. Similarly, with sEMGpara%max only a single subject demonstrated more than a 2% change in NRD between the different postures. These data represent the breath-by-breath variability between some individuals.

This is the first study to demonstrate that NRD, as measured by sEMGpara%max is obtainable in patients with Duchenne muscular dystrophy. Furthermore, NRD was observed in all postures studied and did not significantly change on lying flat or in the lateral postures in this group of patients. From observation of the raw traces the clarity of the signal was mainly due to the absence of tonic postural interference rather than an increase in the raw EMG signal. There was however a marked reduction in neural drive in the supine and lateral postures in a single DMD patient. On further review this patient had severe disease characterised by an FVC of only 13% predicted, with the highest tidal sEMGpara%max in a 45 degree posture of 16%. The reduction in neural respiratory drive may be explained by respiratory muscle wasting and loss of muscle mass in this individual leading to reduced respiratory muscle recruitment suggesting some variability in patient responses to posture depending on the capacity of the respiratory muscle pump. However, as mentioned earlier, Druz *et al.* have described greater activation of the respiratory muscles in the upright posture in healthy subjects and so this may represent normal variation, whereas, the other patients do not drop their neural respiratory drive due to decreasing efficiency of the respiratory muscles.(130). Indirect correlations were observed, albeit with only 4 patients and so lacked statistical significance, between neural respiratory drive and lung function and body composition. In the Duchenne Muscular Dystrophy patients, a lower BMI and lower FVC was associated a higher level of neural respiratory drive. Further work investigating neural respiratory drive in in a larger sample of Duchenne muscle dystrophy patients with variable disease severity is ongoing.

### **3.5 Conclusion**

sEMGpara%max provides a useful, non-invasive alternative measurement of NRD in both healthy subjects and Duchenne muscular dystrophy patients. The sEMGpara%max signal is most easily measured in healthy subjects in postures of 45 degrees, 90 degrees and lying flat and importantly neural respiratory drive did not change significantly in these positions. sEMGpara%max is less easily

measured in healthy subjects in the lateral posturing. However, the lateral posture sEMGpara%max measurement is possible if the subject has a higher level of sEMGpara%max (>4%) when measured during tidal breathing seated at 45 degrees. Alternatively, EMGdi%max can be employed as this is more reproducible albeit a more invasive monitoring technique. Finally, NRD can be reliably measured using sEMGpara%max in all postures in patients with Duchenne muscular dystrophy. sEMGpara%max may therefore be used as useful non-invasive monitoring tool to assess the changes in NRD in these patients during sleep overnight.

# **Chapter 4 Pilot randomised controlled trial of physiological surface second intercostal parasternal electromyography (sEMGpara) set up of home mechanical ventilation compared to standard physician led set up**

## **4.1 Introduction**

Home mechanical Ventilation (HMV) has been shown to improve respiratory muscle unloading, gas exchange, health related quality of life and confer a survival benefit in certain patient groups with chronic ventilatory failure.(39, 40, 51, 67, 133) Increasing patient numbers and increasing physician experience with non-invasive ventilation has led to widespread HMV use as a treatment.(134)

Poor patient ventilator synchronisation may adversely impact on the benefits obtained from HMV in terms of respiratory muscle unloading, gas exchange, sleep quality, patient comfort and adherence to HMV.(8, 75, 76, 89, 135) Furthermore, Thille *et al.* have demonstrated an association with the frequency of patient ventilator asynchrony (PVA) and ventilator settings such as pressure support levels, trigger sensitivity and inspiratory time.(77)

When initiating HMV for patients in chronic hypercapnic ventilatory failure, ventilator settings have traditionally either been protocolised or titrated to correct arterial blood gases in combination with reports of patient tolerability. Previous studies have suggested that titrating ventilator settings to a detailed physiological assessment of the patient could improve upon standard HMV set ups by enhancing patient ventilator interaction.(75, 136) The ventilator manipulations performed in these studies were titrated to reduce measurements of transdiaphragmatic pressure and intrinsic end inspiratory positive airway pressure.(75, 136) An alternative marker of measuring patients' inspiratory effort has been to assess the neural drive to the diaphragm using crural diaphragm electromyogram (EMGdi).(30) Ventilatory pressures have been titrated to maximally unload the diaphragm reducing the EMGdi signal and synchronise the ventilator to the patients' neural inspiratory time with a modality of ventilation called neurally adjust ventilator assist (NAVA).(120, 137-140)

These methods of physiological assessment require the insertion of a nasogastric catheter. The invasive nature of this procedure is challenging in awake, non-sedated patients and therefore its use has been limited outside an intensive care environment. A study assessing its applicability in patients receiving non-invasive ventilation in an acute setting demonstrated that it was often poorly tolerated and signal acquisition was difficult to achieve.(141)

The parasternal intercostal muscles are obligate inspiratory muscles that act to stabilise the chest wall from the descent of the diaphragm and contract in concert during inspiration.(121, 122, 142) The peak rectified surface electromyogram signal from the second intercostal space parasternal muscles (sEMGpara) has been found to be similar to the diaphragm and hence sEMGpara measurements have been used as a reliable non-invasive alternative to EMGdi in assessing neural respiratory drive.(143, 144) sEMGpara has been correlated with markers of breathlessness and shown to be sensitive to change, both in a research setting following threshold loading, hypercapnic ventilator responses and clinically as a predictor of changing disease severity.(124, 127, 131, 145) Furthermore, the sEMGpara signal has previously been used overnight as a reliable breath by breath marker of neural respiratory drive in asthmatics and healthy subjects.(125) These factors suggest sEMGpara may act as a suitable measure of respiratory muscle unloading and patient ventilator synchronisation during the application of nocturnal HMV. This is the first study to examine the role of sEMGpara in the titration of ventilator settings in mechanical ventilation.

#### **4.1.1 Study Hypothesis**

We hypothesised that using sEMGpara as a novel non-invasive physiological marker to titrate individualised ventilatory pressures, identify and correct patient ventilator asynchrony will improve patient adherence to HMV at 3 months compared to a standard protocolised physician led set up of HMV.

We also aimed to examine the effect of the sEMGpara titration of HMV on secondary outcomes such as gas exchange, respiratory muscle unloading, health-related quality of life measures, patient perception of HMV and the length of hospital stay for initiation of HMV as secondary outcome measures.

## **4.2 Methods**

### **4.2.1 Patients**

All patients provided written consent prior to enrolment. The study was approved by the Harrow National Research Ethics Service, London and the research was conducted in accordance with the Helsinki declaration. The study was registered prospectively on a public database (ClinicalTrials.gov - NCT01371149).

Patients were recruited from referrals to the Lane Fox Respiratory Unit, St. Thomas' Hospital requiring initiation of non-invasive ventilation.

Patients with chronic ventilatory failure (awake daytime PaCO<sub>2</sub> > 6kPa) secondary to chronic obstructive pulmonary disease (COPD), obesity related respiratory failure (ORRF) or neuromuscular and chest wall disease (NMD-CWD) were enrolled. Patients with an overlap of COPD and ORRF, including obstructive sleep apnoea, were categorised based on the predominant disease pathology as assessed by obstructive or restrictive pulmonary mechanics (e.g. FEV<sub>1</sub>/FVC < 0.7 obstructive; FEV<sub>1</sub>/FVC > 0.7 restrictive).

### **4.2.2 Detailed Patient Eligibility Criteria**

#### *Inclusion Criteria*

- 1) Patients with confirmed neuromuscular disorders, chest wall disease, chronic obstructive pulmonary disease or obesity hypoventilation syndrome.
- 2) Patients with evidence of nocturnal hypoventilation with an arterial carbon dioxide partial pressure of >6.0 kPa on waking in the morning.
- 3) Patients with evidence of hypercapnic respiratory failure with an arterial carbon dioxide partial pressure of >6.0 kPa during the day.
- 4) Age over 16 years old.
- 5) No prior domiciliary ventilation.

### *Exclusion Criteria*

- 1) Patients with other life threatening co-morbidities e.g. cancer or severe cardiac failure.
- 2) Patients with an unconfirmed diagnosis of neuromuscular disease, obesity hypoventilation syndrome or chronic obstructive pulmonary disease.
- 3) Patients who have had an acute illness within the last 4 weeks prior to starting assessment for ventilation.
- 4) Patients who have an abnormal bleeding tendency (INR >1.4 or platelets <100).
- 5) Patients with a psychological, social or geographical situation that would impair compliance with the project.

### **4.2.3 Study Design**

The study was a prospective pilot randomised controlled trial. Patients were randomly allocated via minimisation to either standard clinical care using overnight oximetry and capnography to titrate NIV settings or physiological sEMGpara led set up to optimise NIV settings through identification and correction of patient ventilator asynchrony. Minimisation criteria were based on spirometry values FEV<sub>1</sub>/FVC more or less than 0.7, BMI more or less than 25 kg/m<sup>2</sup> and an age above or below 50 years. (See trial schematic in appendix 3).

### **4.2.4 Primary Outcome**

The primary outcome was adherence to non-invasive ventilation at 3 months. Secondary exploratory outcomes included PVA, NRD, gas exchange, health related quality of life, patient perceived comfort and length of hospital set up.

### **4.2.5 Home mechanical ventilation set up**

HMV was set up in pressure support mode and provided by a portable home ventilator, the NIPPY3+ ventilator (B&D Electromedical, Stratford-upon-Avon, UK). Ventilation was delivered to all patients

using an oral-nasal mask (Mirage Quattro, ResMed, San Diego, CA, USA) on the first night of HMV. Subsequently, 1 patient with NMD with compatible pressures was issued a nasal mask (nasal swift FX, ResMed, San Diego, CA, USA) at 6 weeks, 3 patients were issued with a total face mask (Philips Respironics, Murrysville, PA, USA) at 6 weeks (1 NMD patient, 1 COPD patient and 1 ORRF patient) for management of pressure sores. The back-up rate was set at 2 breaths below the resting respiratory rate for both groups.

#### *Physiological sEMGpara set up*

Ventilatory pressure support was titrated during the daytime prior to the first night of HMV according to the sEMGpara levels with the aim of reducing the sEMGpara by more than 50% or until pressure tolerability was reached by the patient.

Once an optimal pressure support was achieved the patient was left on ventilation for 30 minutes whilst PVA was assessed. Ventilator trigger settings were manipulated to minimise patient ventilator asynchrony using a pragmatic standardised approach to addressing common causes of PVAs (See appendix 2).

Safety parameters were applied to further manipulate the ventilator settings overnight if the transcutaneous carbon dioxide (TcCO<sub>2</sub>) rose 2 kPa from the baseline values or the patients oxygen levels measured by pulse oximetry (SpO<sub>2</sub>) fell below 80% for more than 10 minutes (TOSCA 500, Radiometer, Crawley, West Sussex, UK).

#### *Physician led set up*

Ventilatory pressure support was titrated overnight to optimise nocturnal SpO<sub>2</sub> and TcCO<sub>2</sub>. Protocolised titration was performed by nursing staff according to the patients underlying disease group as is standard practice in our unit. No overnight assessment of patient ventilator synchronisation occurs and alterations of ventilator trigger settings are not routinely performed. (See appendix 1)(79).

Nursing staff performed hourly observations on all patients' overnight recording ventilator settings, sleep status, SpO<sub>2</sub> and TcCO<sub>2</sub> measurements which was presented to the physician along with the overnight download from the TOSCA 500 (Radiometer, Crawley, West Sussex, UK) the following morning. Physicians were not aware of PVAs overnight that were analysed offline post discharge.

#### **4.2.6 Measurements**

##### *Daytime measurements*

Patients underwent baseline height and weight measurements, arterial blood gases, baseline spirometry (Microplus handheld spirometer, Cardinal Health, OH, USA), non-invasive respiratory muscle strength tests (Micromedical Ltd, Kent, UK) and sEMGpara measurements during 2 minutes of tidal breathing and maximal inspiratory manoeuvres (MIP and SNIP). Duchenne muscular dystrophy patients, Becker muscular dystrophy and spinal muscular atrophy patients who were unable to stand had their height approximated by measuring their arm span with a tape measure.

Health-related quality of life questionnaires were completed (severe respiratory insufficiency (SRI), St. George's respiratory questionnaire (SGRQ), Research and Development- 36 questionnaire (RAND-36), Epworth sleepiness score (ESS), fatigue severity scale (FSS), visual analogue scales for energy levels, sleep comfort, ventilator comfort, patient-ventilator co-ordination, pressure tolerability and a bespoke questionnaire examining the patients assessment of patient-ventilator asynchrony levels (PVIQ).

These assessments were repeated at six weeks and again with a repeat overnight assessment on ventilation at 3 months. (See trial schematic appendix 3).

##### *Nocturnal measurements*

*Night 1:* sEMGpara was measured whilst patients self-ventilated without supplemental oxygen. Each breath during a 2 minute epoch, measured every 10 minutes, over seven hours (or as long as the patient slept) was analysed. This technique was used as previously described by Steier *et al.* to assess sEMGpara nocturnally in asthmatic patients.(125) Signals with movement artefact were

excluded and the closest 2 minute epoch that was artefact free was assessed. Respiratory inductance plethysmography bands were applied to measure concurrent chest wall and abdominal excursion and nasal pressure measurements were obtained confirming inspiratory flow. SpO<sub>2</sub> and TcCO<sub>2</sub> measurements (TOSCA 500, Radiometer, Crawley, West Sussex, UK) were used to assess the adequacy of nocturnal ventilation.

*Night 2:* sEMGpara was measured in a similar manner on ventilation over the same time period. PVA was analysed over the same 2 minute epochs, every 10 minutes over seven hours (or as long as the patient tolerated HMV). To standardise the data the asynchrony are expressed as the percentage of breaths analysed allowing for variable HMV use overnight. PVA were reported in accordance with standardised definitions described in the Methods section of the thesis. (Section 2.9/Pages 71-78). Respiratory inductance plethysmography bands were applied to measure concurrent chest wall and abdominal excursion and mask pressure measurements (Pmo) were obtained to evaluate patient ventilator synchronisation. SpO<sub>2</sub> and TcCO<sub>2</sub> measurements (TOSCA 500, Radiometer, Crawley, West Sussex, UK) were again used to assess the adequacy of nocturnal ventilation.

At 3 months post HMV therapy, sEMGpara and PVA were measured again and analysed as during night 2 during NIV set up.

#### **4.2.7 Analysis and statistics**

sEMGpara, respiratory inductance plethysmography and pressure data were recorded on LabChart v7.3 software (AD Instruments Ltd, Oxford, UK) and saved on a password protected DELL desktop computer (Dell Corporation Limited, Bracknell, UK). Analysis of anonymised data was then performed offline on a password protected HP laptop (Hewlett-Packard Ltd, Bracknell, UK).

Anthropometric data, were normally distributed and are presented as mean and standard deviation. All other data were non-parametric and are presented as median value with the inter-quartile range. Statistical comparisons were performed as described in Materials and Methods Section 1.10.3.

For all analyses, a p-value <0.05 was considered statistically significant.

### *Power Calculation*

A power calculation was not used. Neural respiratory drive measures using sEMGpara had not previously been used in patient groups with chronic respiratory failure with no effect size data available to assess patient ventilator asynchrony levels in these patients. We were therefore unclear as to what levels of reduction in either of these parameters would be clinically meaningful. We therefore conducted a pilot randomised controlled study to determine any differences; with the aim of recruiting 40 patients. This would allow us to power any future trial.

## **4.3 Results**

### **4.3.1 Recruitment**

40 patients (25 male) were enrolled in the trial. This included 16 patients with COPD, 13 patients with ORRF and 11 patients with NMD-CWD. Overall 119 patients were screened for eligibility, with a majority excluded because although referred for home mechanical ventilation these patients did not demonstrate daytime or nocturnal hypercapnia. Twenty one patients were randomised to the physiological HMV set up and these comprised of 9 COPD patients, 6 ORRF patients and 6 NMD-CWD patients. Nineteen patients were randomised to the physician led set up including 7 COPD patients, 7 ORRF patients and 5 MND-CWD patients. Six patients were lost to follow up from the trial; one was withdrawn immediately post the intervention due to a sudden life threatening exacerbation of COPD, 3 did not attend follow-up or no longer wished to attend, 1 patient died prior to the 6 week follow up and 1 declined to continue with HMV therapy. In addition, 1 patient was unable to attend for a 3 month overnight study but otherwise remained compliant with the trial protocol and attended for a day visit. (See Trial Consort Diagram Appendix 4). .

### 4.3.2 Detailed baseline patient anthropometrics

**Table 12: Initial patient baseline characteristics: categorised by physiological and physician led HMV set up**

<b>Characteristics</b>	<b>Total cohort (n=40)</b>	<b>Physiological led HMV set up (n=21)</b>	<b>Physician led HMV set up (n=19)</b>	<b>Statistical difference between treatment groups (p-value)</b>
<b>Age (yrs)</b>	58 (± 17)	55 (± 17)	60 (± 18)	p=0.3
<b>BMI (kgm<sup>-2</sup>)</b>	33.4 (± 9.6)	33.7 (± 11.0)	33.0 (± 8.0)	p=0.8
<b>FEV<sub>1</sub> (%pdt)</b>	38.4 (± 18.5)	38.2 (± 19.6)	38.6 (± 17.7)	p=0.9
<b>FVC (%pdt)</b>	48.7 (± 21.5)	51.0 (± 24.4)	46.0 (± 18.1)	p=0.5
<b>FEV<sub>1</sub>/ FVC (%)</b>	67.3 (± 21.7)	65.4 (± 22.7)	69.4 (± 21.0)	p=0.6
<b>SNIP (cmH<sub>2</sub>O)</b>	45.6 (± 22.5)	46.3 (± 23.9)	44.7 (± 21.5)	p=0.8
<b>MIP (cmH<sub>2</sub>O)</b>	41.3 (± 23.6)	45.0 (± 25.7)	37.2 (± 21.0)	p=0.3
<b>MEP (cmH<sub>2</sub>O)</b>	66.4 (± 39.8)	74.5 (± 44.6)	58.0 (± 33.3)	p=0.2
<b>pH</b>	7.38 (± 0.02)	7.38 (± 0.03)	7.38 (± 0.01)	p=0.9
<b>PaO<sub>2</sub> (kPa)</b>	8.17	8.08	8.27	p=0.7

	(± 1.76)	(± 2.14)	(± 1.28)	
<b>PaCO<sub>2</sub> (kPa)</b>	7.36	7.50	7.22	p=0.5
	(± 1.19)	(± 1.34)	(± 1.00)	
<b>cHCO<sub>3</sub> (mmol/l)</b>	31.8	32.3	31.3	p=0.5
	(± 4.2)	(± 4.8)	(± 3.6)	
<b>Tidal</b>	15.5	12.9	16.9	p=0.8
<b>sEMGpara%max</b>	(9.9-25.5)	(10.6-26.3)	(8.0-25.3)	
<b>(%)</b>				

*Abbreviations: yrs= years, BMI= body mass index, FEV<sub>1</sub>= forced expiratory volume in 1 second, FVC= forced vital capacity, SNIP= sniff nasal inspiratory pressure, MIP= maximal inspiratory pressure, MEP= maximal expiratory pressure, PaO<sub>2</sub> =arterial oxygenation, PaCO<sub>2</sub> = arterial carbon dioxide level, cHCO<sub>3</sub> =corrected bicarbonate level, tidal sEMGpara%max= surface second intercostal parasternal electromyogram during 2 minutes of tidal breathing normalised to the maximum inspiratory electromyogram, HMV= home mechanical ventilation.*

There were no between group differences in baseline characteristics observed between physiological and physician led HMV set up. In addition, there were no within group changes from baseline in lung function, respiratory muscle function or resting neural respiratory drive following 3 months of HMV in either group.

**Table 13: Patient baseline characteristics: categorised by disease group**

<b>Characteristics</b>	<b>COPD patient group (n=16)</b>	<b>ORRF patient group (n=13)</b>	<b>NMD-CWD patient group (n=11)</b>	<b>Statistical difference between disease groups (p-value)</b>
<b>Age (yrs)</b>	63	63	43	p=0.02
	(± 11)	(±16 )	(± 19)	
<b>BMI (kgm<sup>-2</sup>)</b>	31.4	40.1	26.6	p<0.01

	(± 8.8)	(± 7.5)	(± 8.4)	
<b>FEV<sub>1</sub> (L/s)</b>	0.84	1.48	0.79	p=0.001
	(± 0.40)	(± 0.65)	(± 0.28)	
<b>FVC (L)</b>	1.85	1.87	0.92	p<0.001
	(± 0.53)	(± 0.83)	(± 0.36)	
<b>FEV<sub>1</sub> /FVC (%)</b>	43.8	79.4	86.9	p<0.0001
	(± 10.5)	(± 8.3)	(± 9.2)	
<b>SNIP (cmH<sub>2</sub>O)</b>	54.3	53.0	24.2	p<0.001
	(± 18.8)	(± 18.7)	(± 18.5)	
<b>MIP (cmH<sub>2</sub>O)</b>	51.7	44.5	22.4	p<0.01
	(± 21.7)	(± 22.8)	(± 16.1)	
<b>MEP (cmH<sub>2</sub>O)</b>	79.9	80.9	33.6	p<0.01
	(± 36.3)	(± 36.8)	(± 26.0)	
<b>pH</b>	7.38	7.38	7.38	p=0.7
	(± 0.03)	(± 0.03)	(± 0.02)	
<b>PaO<sub>2</sub> (kPa)</b>	7.11	8.53	9.18	p<0.01
	(± 1.17)	(± 1.51)	(± 2.13)	
<b>PaCO<sub>2</sub> (kPa)</b>	7.53	7.35	7.19	p=0.8
	(± 1.00)	(± 1.22)	(± 1.49)	
<b>cHCO<sub>3</sub> (mmol/l)</b>	32.8	31.0	31.4	p=0.5
	(± 3.5)	(± 4.2)	(± 5.1)	
<b>sEMGpara%max</b>	10.7	16.0	27.3	p<0.01
<b>(%)</b>	(7.8-16.0)	(10.6-19.5)	(16.5-39.1)	

*Abbreviations: yrs= years, BMI= body mass index, FEV<sub>1</sub>= forced expiratory volume in 1 second, FVC= forced vital capacity, SNIP= sniff nasal inspiratory pressure, MIP= maximal inspiratory pressure, MEP= maximal expiratory pressure, PaO<sub>2</sub> =arterial oxygenation, PaCO<sub>2</sub> = arterial carbon dioxide level, cHCO<sub>3</sub> =corrected bicarbonate level, tidal sEMGpara%max= surface second intercostal parasternal electromyogram during 2 minutes of tidal breathing normalised to the maximum inspiratory electromyogram, COPD= chronic obstructive pulmonary disease, ORRF= obesity related respiratory failure, NMD-CWD= neuromuscular and chest wall disease.*

NMD-CWD patients were significantly younger with lower FVC, inspiratory and expiratory muscle strength measures than the other disease groups. The neural respiratory drive was also significantly higher during tidal breathing in the NMD-CWD disease group. As expected, the COPD patients had significantly lower FEV<sub>1</sub>/FVC ratio as reflective of their obstructive airways disease but these were also the most hypoxic patient group. The obese patient group as predicted had the largest BMI.

No significant changes were observed in the tidal neural respiratory drive in any disease group considering all patients that completed the trial between the baseline level, 6 weeks and 3 months post HMV therapy (COPD patients (p=0.5), ORRF patients (p= 0.5), NMD-CWD patients (p=0.6)).

#### 4.3.3 Ventilator settings between the physiological HMV set up and physician led HMV set up

**Table 14: HMV ventilator settings post set up at hospital discharge: categorised by physiological and physician led HMV set up**

Ventilator parameters	Physiological HMV (n=21)	led set up	Physician led HMV set up (n=19)	Statistical difference between treatment groups (p-value)
<b>IPAP (cmH<sub>2</sub>O)</b>	24 (22-26)		24 (20-28)	p=0.9
<b>EPAP (cmH<sub>2</sub>O)</b>	8 (4-10)		8 (3-10)	p=0.5
<b>Ti (s)</b>	1.2 (1.0-1.2)		1.2 (1.0-1.2)	p=1.0
<b>BUR (breath/min)</b>	14 (12-14)		14 (14-16)	p=0.1
<b>Trig<sub>insp</sub></b>	3 (2-4)		4 (4-4)	p=0.02
<b>Trig<sub>exp</sub></b>	4 (3-5)		4 (4-4)	p=0.2

<b>Patient triggered breaths (%)</b>	39.1 (16.7-65.4)	45.8 (28.1-62.3)	p=0.5
<b>Non-triggered ventilator delivered breaths (%)</b>	43.7 (23.8-71.0)	33.1 (22.0-58.9)	p=0.3

Abbreviations: IPAP= inspiratory positive airways pressure, EPAP= expiratory positive airways pressure, Ti= inspiratory time, BUR= back up rate, Trig<sub>insp</sub>= inspiratory trigger, Trig<sub>exp</sub>= expiratory trigger, cmH<sub>2</sub>O= centimetres of water, s = seconds, HMV= home mechanical ventilation.

The only statistically significant difference between the ventilator settings in the physician led HMV set up and the physiological led set up was a lower inspiratory trigger in the physiological led set up. Despite this, no statistically significant difference in the percentage of patient triggered breaths was observed.

**Table 15: HMV ventilator settings post set up at hospital discharge: categorised by disease group**

<b>Ventilator parameters</b>	<b>COPD patients</b>	<b>ORRF patients</b>	<b>NMD-CWD patients</b>	<b>Statistical difference between disease groups (p-value)</b>
<b>IPAP (cmH<sub>2</sub>O)</b>	19.0 (18.0-25.8)	20.0 (18.0-24.5)	20.0 (16.0-24.0)	p=0.7
<b>EPAP (cmH<sub>2</sub>O)</b>	7.0 (4.0-8.0)	8.0 (6.0-9.0)	3.0 (3.0-6.0)	p=0.04
<b>Ti (s)</b>	1.1 (1.0-1.2)	1.2 (1.2-1.3)	1.2 (1.2-1.2)	p<0.01
<b>BUR (breath/min)</b>	14.0 (10.5-15.5)	14.0 (14.0-14.0)	14.0 (14.0-16.0)	p=0.3

<b>Trig<sub>insp</sub></b>	4.0 (3.0-4.0)	4.0 (3.0-4.0)	4.0 (2.0-4.0)	p=0.9
<b>Trig<sub>exp</sub></b>	4.0 (4.0-4.8)	4.0 (4.0-4.8)	4.0 (4.0-4.0)	p=0.9
<b>Patient triggered breaths (%)</b>	47.6 (32.4- 74.8)	48.9 (29.3-62.6)	28.3 (12.7-47.7)	p=0.04
<b>Non-triggered ventilator delivered breaths (%)</b>	28.2 (13.3-52.5)	33.1 (22.6-52.6)	67.9 (41.4-81.7)	p<0.01

Abbreviations: IPAP= inspiratory positive airways pressure, EPAP= expiratory positive airways pressure, Ti= inspiratory time, BUR= back up rate, Trig<sub>insp</sub>= inspiratory trigger, Trig<sub>exp</sub>= expiratory trigger, cmH<sub>2</sub>O= centimetres of water, s = seconds, COPD = chronic obstructive pulmonary disease, ORRF= obesity related respiratory failure, NMD-CWD= neuromuscular and chest wall disease.

As expected, the levels of EPAP were significantly lower in the NMD-CWD group. The inspiratory time was significantly lower in the COPD patient group as is common practice to facilitate lung emptying. Patients with neuromuscular disease were significantly more likely to receive a higher percentage of non-triggered breaths and a lower percentage of triggered breaths at initiation of ventilation.

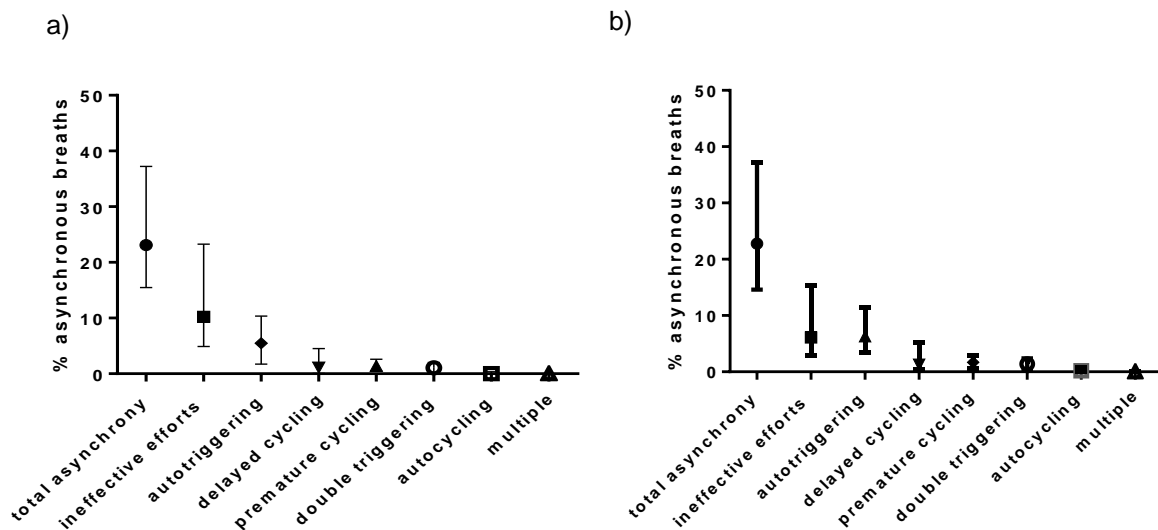
#### 4.3.4 Prevalence of patient-ventilator asynchrony

No significant difference was observed in the frequency of PVA between the physician led set up and the physiological led set up of HMV at initiation or 3 months (28.4 (17.4-37.6)% vs 25.6 (14.0-30.4)%; p=0.6 and 22.4 (13.3-37.1)% vs 23.3 (15.2-41.5)% p=0.7, respectively).

Overall, PVA affected 25.6 (16.4-35.7)% breaths at initiation of HMV, with ineffective efforts as the predominant type of PVA accounting for 10.9 (4.6-23.7)% of breaths. Of clinical importance, there

was no improvement observed in PVA 3 months post HMV therapy with 22.8 (14.6-37.1)% affected ( $p=0.6$ ). (Figure 40).

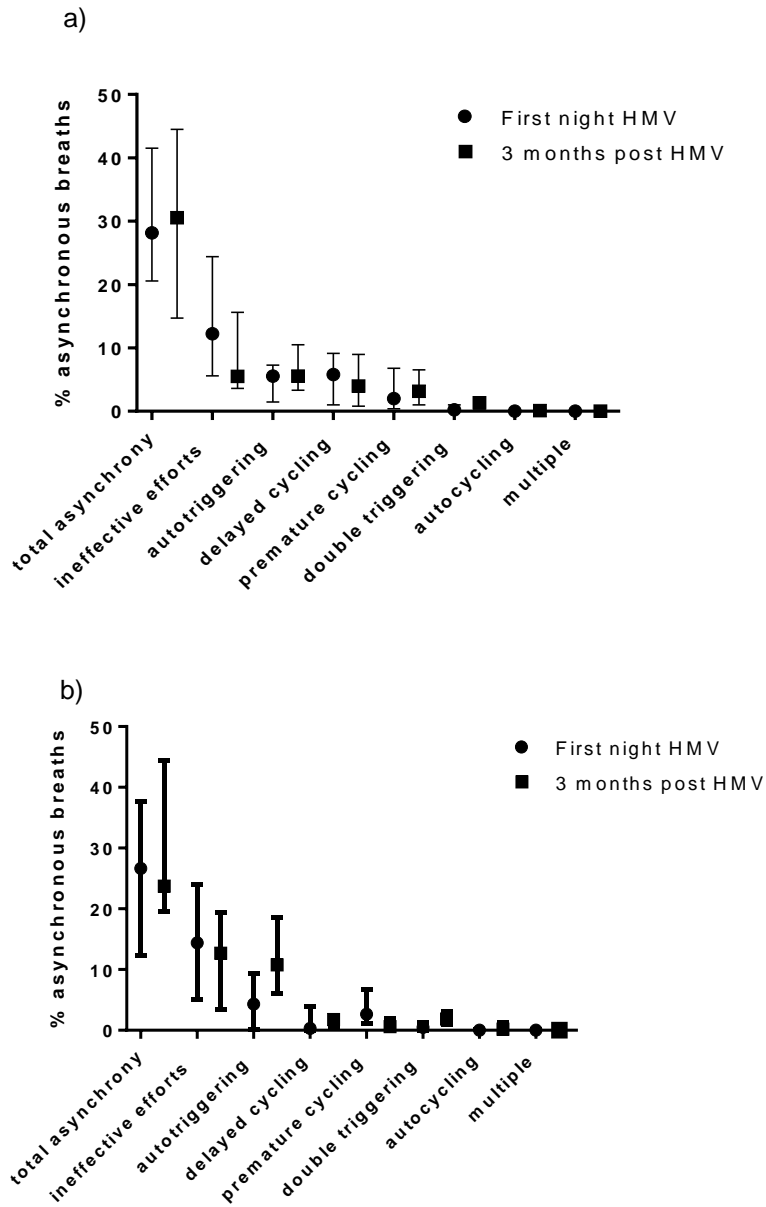
**Figure 38: Prevalence of patient ventilator asynchrony during a) the initiation of HMV and b) following 3 months HMV therapy**

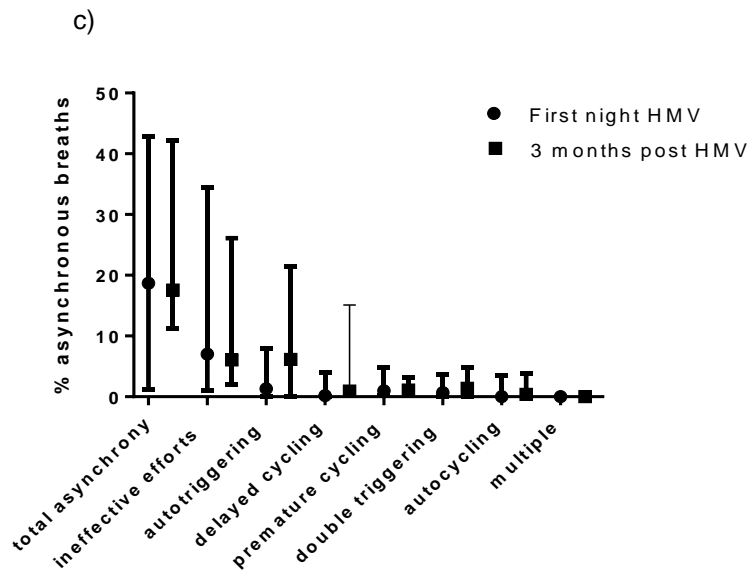


No significant difference was observed in the total amounts of asynchrony between the patient disease groups on the first night of HMV and 3 months post HMV therapy (First night: COPD 28.2 (20.6-41.5)%, ORRF 26.7 (12.3-37.6)%, NMD-CWD 18.7 (11.4-21.5)%;  $p=0.06$ , 3 months: COPD 30.6 (14.7- 44.5)%, ORRF 23.7 (19.6-44.5)%, NMD-CWD 17.6 (11.3-27.9)%;  $p=0.3$ ).

COPD patients had higher proportions of delayed cycling than NMD-CWD patients on the first night of HMV ( $p=0.02$ ) and higher levels of premature cycling than ORRF patients 3 months post HMV therapy ( $p=0.01$ ).

**Figure 39: Prevalence of patient ventilator asynchrony at initiation of HMV and 3 months post HMV therapy in a) COPD patients, b) ORRF patients and c) NMD-CWD patients**





#### 4.3.5 Primary outcome: Adherence to HMV therapy at 3 months

There was no significant difference observed in the mean daily adherence to non-invasive ventilation between the physiological led HMV set up group and the physician led HMV set up group at 3 months. (Table 16).

**Table 16: Comparison between adherence to HMV in the physiological sEMGpara led set up of HMV and the physician led set up of HMV**

Assessment period	Physiological led HMV set up (n=19- 6 weeks, n=17 -3 months)	Physician led HMV set up (n=16 -6 weeks, n=17- 3 months)	Statistical difference between treatment groups (p-value)
<b>6 week</b>	3hr40 (1hr43-6h38)	5hr26 (1hr48-7hr31)	p=0.48
<b>3 month</b>	4hr27 (2hr15-7hr02)	6hr34 (1hr57-7hr24)	p=0.39
<b>Daily adherence over 3 months</b>	4hr01 (3hr03-7hr00)	5h50 (1h42-7hr31)	p=0.86

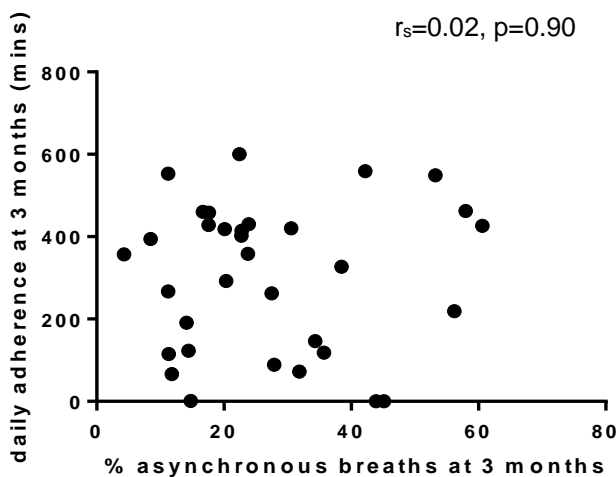
Data are expressed as median and inter-quartile ranges. *Abbreviations:* HMV-home mechanical ventilation

Overall, the daily adherence to HMV therapy was satisfactory at 5hrs 58 minutes (2hrs 02 minutes-7hrs 09 minutes) at 3 months. There was a significant improvement in adherence at 3 months compared to the 6 week adherence of 5hrs 00 minutes (2hrs 02 minutes-7hrs 03 minutes) in the whole cohort ( $p=0.02$ ).

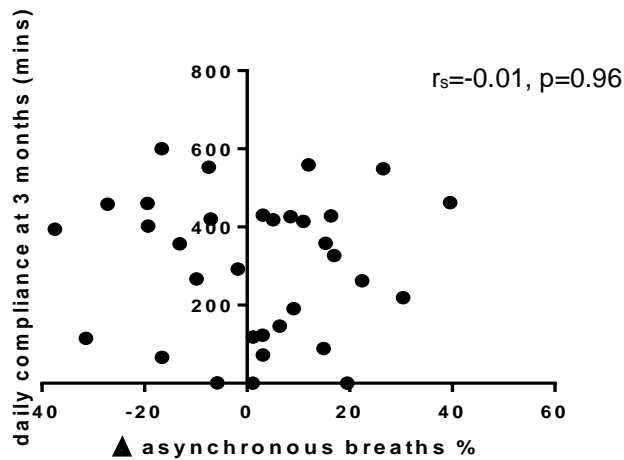
No significant difference was observed in the adherence to HMV at 3 months between the different disease groups ( $p=0.4$ ). COPD patients had the lowest mean daily adherence to HMV at 4hrs 52minutes (1hrs 09minutes -6hrs 59minutes) and ORRF patients the highest mean daily adherence with 6hrs 31minutes (3hrs 46 minutes-8hrs 02 minutes).

There was no relationship observed between the amount of asynchrony at 3 months and patient mean daily adherence to HMV at 3 months. (Figure 42). Furthermore, there was no relationship observed between the change in asynchrony levels over the 3 months of HMV therapy and the mean daily adherence at the 3 months assessment. (Figure 43).

**Figure 40: Relationship between patient ventilator asynchronous breaths at 3 months and average daily adherence to HMV at 3 months (n=32)**



**Figure 41: Relationship between the change in patient ventilator asynchronous breaths and the average daily adherence to HMV at 3 months (n=32)**



#### **4.3.6 Secondary outcome: Gas exchange at 3 months**

There was no significant difference between the improvements in gas exchange in the physiological set up and the physician led set up of HMV following 3 months of HMV therapy. (Table 17).

Considering the total cohort that completed the trial, daytime gas exchange significantly improved following 3 months of HMV therapy as measured by arterial blood gases. Oxygenation increased from 8.3kPa (6.5-9.2) at baseline to 8.4kPa (7.5-9.6);  $p < 0.01$ . Hypercapnia significantly reduced from 7.1kPa (6.4-8.1) to 6.5 (6.0-7.1);  $p < 0.0001$ .

Nocturnal gas exchange also significantly improved over the whole group completing the trial following 3 months of HMV therapy. Mean overnight oxygen saturations ( $SpO_2$ ) improved from 90% (82-94) to 94% (92-97%);  $p < 0.0001$ . Mean overnight transcutaneous carbon dioxide ( $TcCO_2$ ) improved from 7.4kPa (6.9-8.3) to 6.4kPa (5.9-7.3);  $p < 0.0001$ .

**Table 17: Change in gas exchange between the physiological sEMGpara led set up and the physician led set up of HMV during 3 months of therapy.**

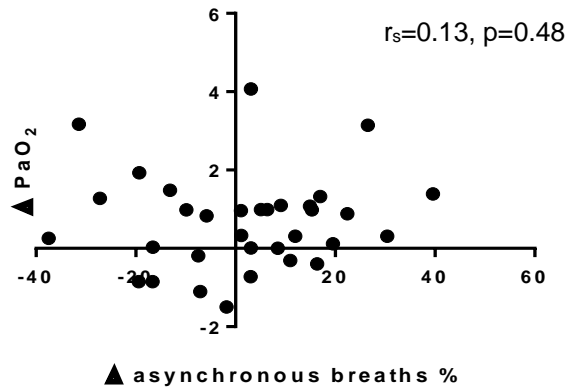
<b>Gas exchange parameters</b>	<b>Physiological led HMV set up (n=17- ABG data, n=16 -nocturnal data)</b>	<b>Physician led HMV set up (n=17)</b>	<b>Statistical difference between treatment groups (p-value)</b>
<b>Δ PaO<sub>2</sub> (kPa)</b>	0.92 (-0.14 - 1.23)	0.33 (-0.20- 1.20)	p=0.72
<b>Δ PaCO<sub>2</sub> (kPa)</b>	-0.65 (-1.24 - -0.20)	-0.34 (-0.92- -0.08)	p=0.45
<b>Δ Nocturnal mean SpO<sub>2</sub> (%)</b>	2.8 (-0.4-11.7)	4.7 (0.9-10.0)	p=0.73
<b>Δ Nocturnal mean TcCO<sub>2</sub> (kPa)</b>	-0.9 (-1.4- -0.5)	-1.08 (-2.13- -0.53)	p=0.64

*Abbreviations:* ABG-arterial blood gas, ΔPaO<sub>2</sub>-change in arterial oxygen levels following 3 months of home mechanical ventilation therapy, ΔPaCO<sub>2</sub>- change in arterial carbon dioxide levels following 3 months of home mechanical ventilation therapy, Δ nocturnal mean SpO<sub>2</sub>-change in the mean overnight oxygen saturation levels following 3 months of home mechanical ventilation therapy. Δ nocturnal mean TcCO<sub>2</sub>-change in the mean overnight transcutaneous carbon dioxide levels following 3 months of home mechanical ventilation therapy, kPa- kilopascals.

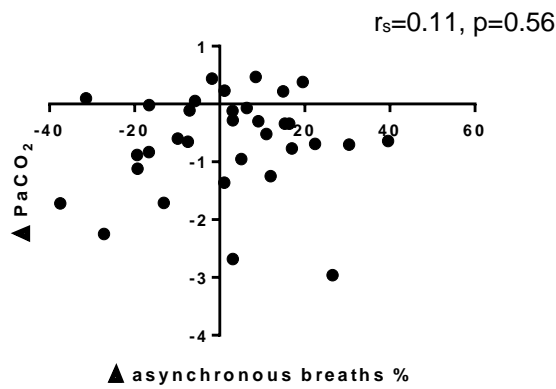
There was no significant difference in the improvements observed in gas exchange between the different disease groups.

There was no relationship observed between the changes in gas exchange and the change in levels of PVA following 3 months of HMV therapy. (Figures 44 and 45). No relationship was observed between the proportion of the night spent with SpO<sub>2</sub> less than 90% or TcCO<sub>2</sub> levels above 7kPa and the amount of PVA at initiation or 3 months post therapy. (Figures 46 and 47).

**Figure 42: Relationship between the changes in daytime arterial oxygenation and the changes in patient ventilator asynchrony with 3 months of HMV**

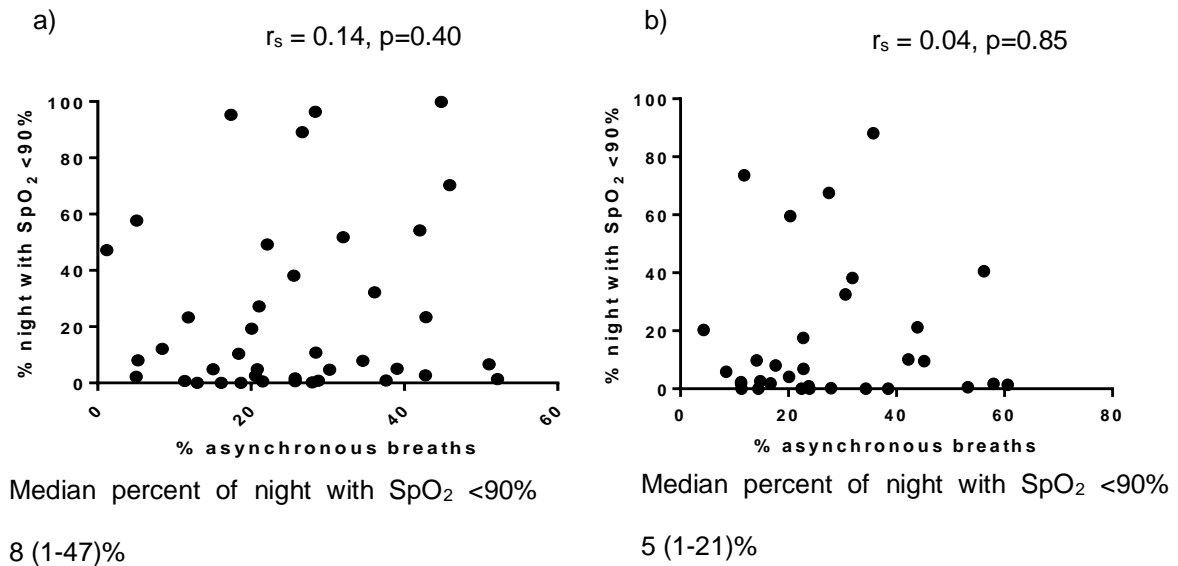


**Figure 43: Relationship between the changes in daytime arterial carbon dioxide and the changes in patient ventilator asynchrony with 3 months of HMV**



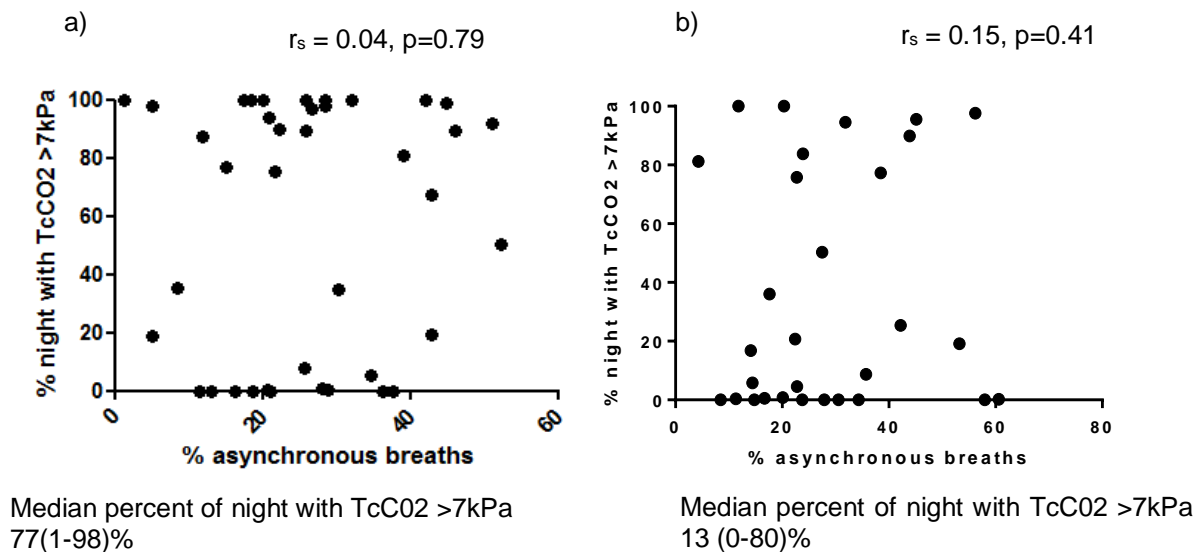
*Abbreviations:*  $\Delta PaO_2$ -change in arterial oxygen levels following 3 months of home mechanical ventilation,  $\Delta PaCO_2$ - change in arterial carbon dioxide levels following 3 months of home mechanical ventilation

**Figure 44: The relationship between patient ventilator asynchrony and nocturnal oxygen saturations at a) initiation and b) 3 months post HMV therapy**



*Abbreviations:* SpO<sub>2</sub>-oxygen saturations.

**Figure 45: The relationship between patient ventilator asynchrony and nocturnal transcutaneous carbon dioxide levels at a) initiation and b) 3 months post HMV therapy**



*Abbreviations:* TcCO<sub>2</sub>-transcutaneous carbon dioxide levels, kPa-kilopascals

No statistically significant relationship was observed between ineffective efforts and the percentage of time overnight spent with oxygen saturations below 90% at 3 months of HMV therapy ( $r_s=0.18, p=0.33$ ). A weak relationship was observed at initiation of HMV ( $r_s=0.33, p=0.04$ ). No association

was observed between gas exchange and any other type of PVA. These findings are in keeping with those previously published by our group in a similar cohort of patients. (79)

#### **4.3.7 Secondary outcome: Changes in respiratory muscle loading measured by sEMGpara%max at 3 months**

Patients in the physician led set up group had higher levels of neural respiratory drive than the physiological led set up group during tidal breathing awake in the daytime;  $p=0.02$ . Neural respiratory drive was significantly reduced in both groups following NIV therapy and this was sustained at 3 months of treatment. (Figure 48).

**Table 18: Changes in neural respiratory drive between the physiological led HMV set up group and the physician led HMV set up group at baseline self-ventilating and baseline HMV set up**

<b>Observation period</b>	<b>Physiological led HMV set up (n=21 Initial tidal, self-ventilating, first night HMV, n=16 3 months post HMV and change over 3 months HMV)</b>	<b>Physician led HMV set up (n=19 Initial tidal, self-ventilating, first night HMV, n=17 3 months post HMV and change over 3 months HMV)</b>	<b>(p-value)</b>
<b>Daytime tidal sEMGpara%max (%)</b>	9.2 (5.0-14.1)	12.9 (10.6-26.3)	p=0.02
<b>Nocturnal self-ventilation mean sEMGpara%max (%)</b>	16.6 (9.7-23.1)	12.9 (10.6-18.6)	p=0.8
<b>First night of HMV therapy mean sEMGpara%max (%)</b>	7.6 (4.0-13.1)	10.1 (6.9-16.1)	p=0.3
<b>3 months post HMV therapy mean sEMGpara%max (%)</b>	8.0 (5.1-11.1)	7.8 (3.1-17.1)	p=0.8

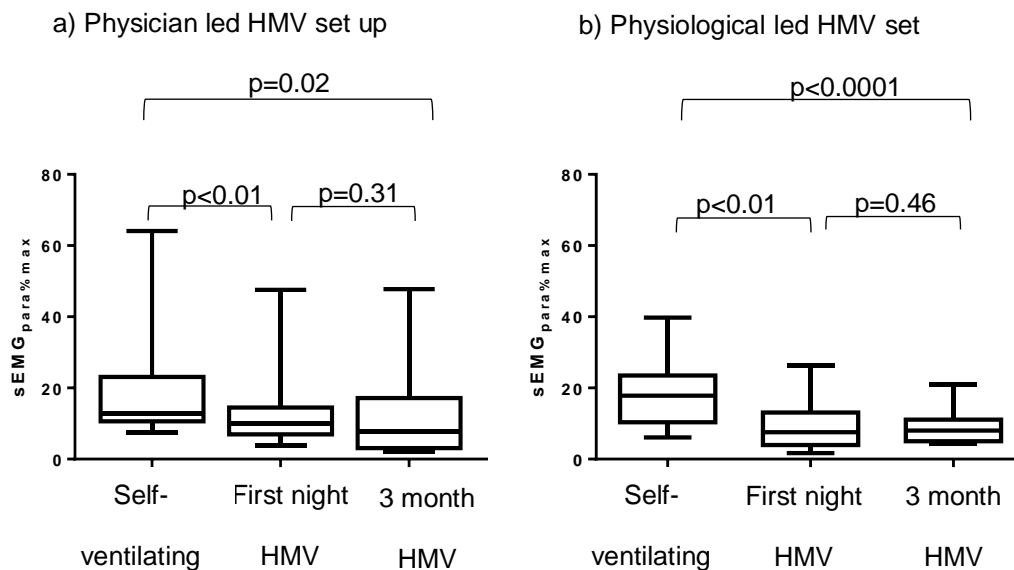
<b>Change in</b>	-8.6	-5.6	p=0.7
<b>sEMGpara%max</b>	(-16.1 to -2.9)	(-12.0 to -2.5)	
<b>between self- ventilation and 3 months HMV therapy (%)</b>			

*Abbreviations:* HMV-home mechanical ventilation, sEMGpara%max-surface second intercostal parasternal electromyogram normalised to a maximal inspiratory manoeuvre,

The first night of HMV demonstrated greater respiratory muscle unloading in the physiological led set up compared to the physician led set up that approached significance (median reduction in sEMGpara%max of -4.7 (-8.8 to -0.7)% in the physiological led set up vs. -1.7 (-3.2 to -0.1)% in the physician led set up; p=0.06). However, at 3 months, there were no between group difference in respiratory unloading (median reduction in sEMGpara%max of -5.6 (-12.0 to -2.5)% in the physiological led set up compared to -8.6 (-16.1 to -2.9)% in the physician led set up; p=0.7).

Importantly, both HMV set up methods over 3 months achieved significant unloading of the respiratory muscles and reduction in neural respiratory drive overnight between self-ventilating and 3 months of HMV therapy (physiological led set up of HMV; p<0.0001, physician led set up of HMV; p=0.02). (Figure 48).

**Figure 46: Changes in neural respiratory drive as measured by sEMGpara%max between the physician led and the physiological led set up of HMV over the 3 months of HMV**



*Abbreviations:* sEMGpara%max-surface parasternal electromyogram normalised to a maximal inspiratory manoeuvre.

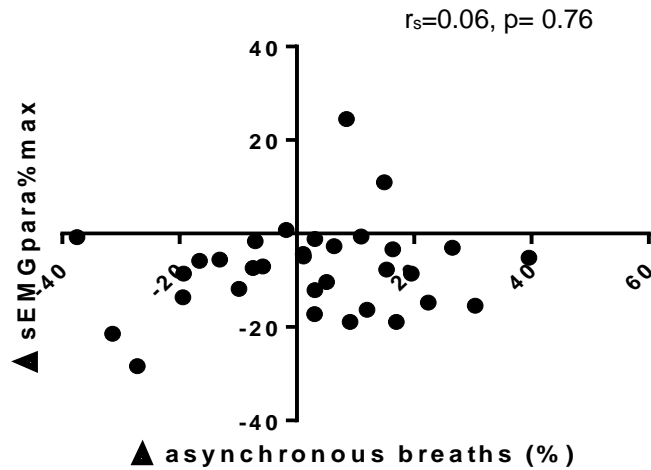
Although there was no between group difference at baseline and 3 months of HMV treatment, the total cohort demonstrated nocturnal respiratory muscle loading and a reduction in neural respiratory drive following 3 months of HMV. Mean nocturnal neural respiratory drive reduced from 13.2% (10.3-22.1) during self-ventilation to 7.8% (4.8-13.8) 3 months post HMV (p-value <0.0001).

This observation held when data was analysed by disease group. The COPD and ORRF group achieved significant respiratory muscle unloading on the first night of HMV therapy (p=0.01 and p<0.001, respectively). The NMD-CWD group achieved significant muscle unloading by 3 months only (p<0.01).

There was no association observed between respiratory muscle unloading and patient ventilator asynchrony during the first night of HMV therapy ( $r_s=0.14$ , p=0.4) or 3 months post HMV therapy ( $r_s=0.24$ , p=0.2). No significant relationship was observed between the changes in respiratory muscle loading and the changes in patient ventilator asynchrony levels following 3 months of HMV therapy. (Figure 49).

There was no association between the incidence of ineffective efforts and neural respiratory drive at initiation of HMV or at 3 months post treatment ( $r_s=0.17$ ,  $p=0.3$  and  $r_s=0.16$ ,  $p=0.4$ ).

**Figure 47: Relationship between the change in respiratory muscle unloading and patient ventilator asynchrony following 3 months of HMV**



*Abbreviations:*  $\Delta sEMGpara\%max$ -change in surface parasternal electromyogram normalised to a maximal inspiratory manoeuvre over 3 months of home mechanical ventilation therapy,  $\Delta asynchronous\ breaths$ - change in asynchronous breaths over 3 months of home mechanical ventilation therapy

#### 4.3.8 Secondary outcome: Health related quality of life measures

There were no differences in health related quality of life outcomes observed between the physiological set up of HMV group and the physician led set up of HMV group following 3 months of HMV. (Table 19).

**Table 19: Change in health related quality of life following 3 months of HMV therapy: comparison of physiological HMV set up and physician led HMV set up**

<b>Health related quality of life score (total)</b>	<b>Physiological HMV set up (n=17)</b>	<b>Physician led HMV set up (n=17)</b>	<b>p-value</b>
<b>SRI (/100)</b>	8.7 (4.8-24.4)	11.3 (-2.9-18.2)	p=0.6
<b>SGRQ (/100)</b>	-3.7 (-8.9-5.7)	-4.6 (-15.3-6.2)	p=0.7
<b>RAND-36</b>	175 (-8-410)	85 (-13-258)	p=0.5
<b>HAD (/24)</b>	-1.0 (-6.5-2.5)	-1.0 (-5.0- -0.5)	p=0.7
<b>ESS (/24)</b>	-2.0 (-8.0-1.5)	-4.0 (-12.0- -0.5)	p=0.8
<b>FSS (/70)</b>	-2.0 (-16.0-6.5)	-7.0 (-12.0-2.0)	p=0.8

*Abbreviations:* SRI=severe respiratory insufficiency questionnaire, SGRQ= St. George's respiratory questionnaire, RAND-36= research and development short form 36 questionnaire, HAD= hospital anxiety and depression scale, ESS= Epworth sleepiness scale, FSS= fatigue severity scale, HMV= home mechanical ventilation.

There was no difference between physiological HMV set up and physician led HMV set up in patient perception of HMV scores or the patient assessment of patient ventilator asynchrony levels post 3 months of HMV therapy. (Table 20).

**Table 20: Change visual analogue scales and patient perception of patient ventilator asynchrony questionnaire following 3 months of HMV therapy: comparison of physiological HMV set up and physician led HMV set up**

<b>Patient perception scores</b>	<b>Physiological set up (n=17)</b>	<b>Physician led HMV set up (n=17)</b>	<b>Statistical significance (p-value)</b>
<b>Energy level VAS (/100)</b>	4.0 (-5.5-22.0)	9.0 (0.0-36.5)	p=0.4
<b>Sleep comfort VAS (/100)</b>	6.0 (1.5-36.0)	26.0 (6.0-33.5)	p=0.5
<b>Ventilator comfort VAS (/100)</b>	-1.0 (-13.5-9.5)	-1.0 (-22.0-14.0)	p=0.9
<b>Co-ordination with HMV VAS(/100)</b>	-6.0 (-22.0-6.5)	10.0 (-27.0-23.5)	p=0.2
<b>Pressure tolerability VAS (/100)</b>	-3.0 (-12.5-4.0)	-10.0 (-24.5-8.5)	p=0.9
<b>Patient assessment of PVA questionnaire (/)</b>	0.0 (-9.0-4.5)	0.0 (-6.0-4.5)	p=0.6

*Abbreviations:* VAS= visual analogue scale, PVA= patient ventilator asynchrony, HMV= home mechanical ventilation, HRQL = health related quality of life.

#### **4.3.8.1 Tolerability of HMV set up**

All patients were naïve to HMV. At initiation, the patient perception of co-ordination with the ventilator was greater in the physiological HMV set up group compared to the physician led HMV set up group (81.5 (72.8-91.5) vs 63.0 (56.0-78.0);  $p < 0.01$ ). All other assessments of ventilator comfort, tolerability of pressures and awareness of PVA levels were not significantly different. There were no differences observed between patient disease groups considering initial perception of HMV set following the first night of therapy except in the perception of pressure tolerability. COPD patients reported the overnight pressures more tolerable than the NMD patients 90.0 (85.0-99.0) and 77.0 (65.0-90.0), respectively ( $p = 0.04$ ).

#### 4.3.8.2 Changes in health related quality of life measures in the total cohort completing the trial

Overall, a significant improvement was observed in health related quality of life scores using the SRI, the RAND-36, the ESS and the HAD following 3 months of HMV therapy. Using these health related quality of life measures, an improvement in HRQL was apparent from 6 weeks post HMV therapy with no further significant increase at 3 months. No significant improvements were observed using the SGRQ or the FSS, although the latter approached significance at 3 months ( $p=0.06$ ). (Table 21).

**Table 21: Total cohort changes in health related questionnaire measures with 3 months of HMV**

Health related quality of life score (total)	Initiation of HMV (n=40)	6 week follow up (n=35)	3 month follow up (n=34)	Change in HRQL between initiation and 3 months (n=34)	Statistical significance between initiation and 3 months (n=34)
<b>SRI (/100)</b>	54.9 (44.2-62.8)	65.2 * (42.3-78.2)	64.8 * (54.3-74.2)	10.2 (0.1-18.9)	$p<0.001^*$
<b>SGRQ (/100)</b>	59.4 (34.9-72.9)	52.9 (39.5-70.9)	52.4 (36.0-65.6)	-4.3 (-12.2-5.3)	$p=0.17$
<b>RAND-36 sum (/3600)</b>	1193 (1005-1724)	1490* (1055-1955)	1473* (1064-2006)	145 (-11.3-361.3)	$p=0.003^*$
<b>HAD (/24)</b>	12.0 (7.3-18.0)	10.0* (7.0-19.0)	9.0* (4.0-14.3)	-1.0 (-6.0-2.0)	$p=0.01^*$
<b>ESS (/24)</b>	10.5 (6.3-15.0)	7.0* (3.0-12.0)	7.0* (3.0-11.5)	-3.0 (-6.0-1.0)	$p=0.007^*$
<b>FSS (/63)</b>	51.0 (34.5-59.0)	43.0 (26.0-52.0)	42.5 (30.0-50.8)	-5.5 (-13.0-6.0)	$p=0.06$

*\*indicates a significant statistical change from baseline HRQL measures, p-value for 3 month changes only is shown.*

*Abbreviations:* SRI=severe respiratory insufficiency questionnaire, SGRQ= St. George's respiratory questionnaire, RAND-36= research and development short form 36 questionnaire, HAD= hospital anxiety and depression scale, ESS= Epworth sleepiness scale, FSS= fatigue severity scale.

Statistically significant improvements in patients' perception of energy levels and sleep comfort were observed following 3 months of HMV in the total cohort of patients receiving HMV therapy. (See Table 22). No significant improvements were observed in patients' perception of ventilator comfort, co-ordination of their breathing with the ventilator or asynchrony levels following 3 months of HMV. Furthermore, patients noticed a reduction in the tolerability of ventilator pressures over the 3 months which approached significance (p=0.06).

**Table 22: Visual analogue scales and patient perception of patient ventilator asynchrony questionnaire**

<b>Patient perception scores</b>	<b>Initiation of HMV (n=40)</b>	<b>6 week follow up (n=35)</b>	<b>3 month follow up (n=34)</b>	<b>Change in HRQL between initiation and 3 months (n=34)</b>	<b>Statistical significance between initiation and 3 months (n=34)</b>
<b>Energy level VAS (/100)</b>	32.0 (23.3-53.8)	45.0 (27.0-59.0)	52.5* (33.0-69.3)	7.5 (-2.0-31.0)	p=0.007*
<b>Sleep comfort VAS (/100)</b>	44.5 (23.5-64.0)	62.0* (51.0-77.0)	69.0* (50.0-79.3)	11.5 (2.0-34.5)	p<0.001*
<b>Ventilator comfort VAS (/100)</b>	64.5 (42.0-88.0)	74.0 (42.0-82.0)	73.0 (45.5-84.3)	-1.0 (-16.0-12.5)	p=0.90
<b>Co-ordination with HMV VAS (/100)</b>	76.5 (58.0-86.0)	77.0 (56.0-84.0)	71.5 (52.5-88.0)	-3.0 (-22.0-13.0)	p=0.56
<b>Pressure tolerability VAS (/100)</b>	86.5 (83.0-96.8)	77.0 (56.0-84.0)	81.5 (63.3-88.3)	-3.0 (-15.5-6.3)	p=0.06
<b>Patient assessment of PVA questionnaire (/)</b>	40.0 (37.3-43.8)	40.0 (35.0-43.0)	40.5 (33.3-45.0)	0.0 (-6.3-4.3)	p=0.57

\*indicates a significant statistical change from baseline HRQL measures, p-value for 3 month changes only is shown.

Abbreviations: VAS= visual analogue scale, PVA= patient ventilator asynchrony, HMV= home mechanical ventilation, HRQL = health related quality of life.

#### 4.3.8.3 Health related quality of life measures comparing the different disease groups receiving HMV therapy

No significant differences were observed in the HRQL outcome measures using the generic HRQL questionnaires between the different disease groups following 3 months of HMV. (Table 23).

**Table 23: Changes in HRQL measures comparing the different disease groups post 3 months of HMV**

Health related quality of life score (total)	COPD patient group (n=13)	ORRF patient group (n=10)	NMD-CWD patient group (n=11)	p-value
<b>SRI (/100)</b>	11.9 (5.0-20.5)	8.9 (-3.5-18.1)	10.2 (-1.9-16.4)	p=0.6
<b>SGRQ (/100)</b>	-3.7 (-12.6-1.7)	-8.8 (-18.2- -1.9)	2.6 (-6.3-9.7)	p=0.1
<b>RAND-36 sum (/3600)</b>	40 (-15-408)	145 (39-305)	275 (30-385)	p=0.9
<b>HAD (/24)</b>	-4.0 (-9.0-2.0)	-1.0 (-4.5-2.0)	-2.0 (-3.0-0.0)	p=0.6
<b>ESS (/24)</b>	-2.5 (-5.5-1.8)	-5.0 (-9.3- -1.0)	0.0 (-4.0-2.0)	p=0.2
<b>FSS (/63)</b>	-11.0 (-15.0- -3.0)	-4.0 (-10.0-6.0)	5.0 (-12.0-10.0)	p=0.2

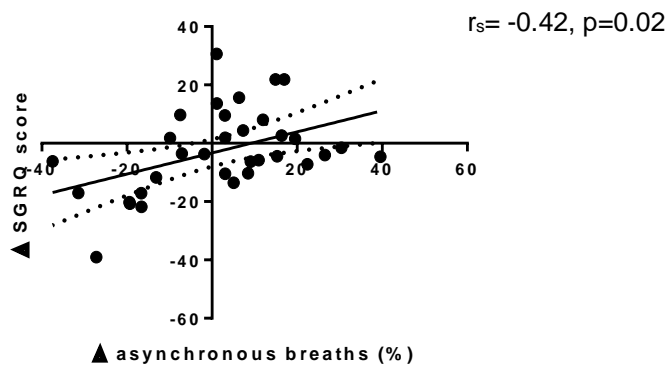
Abbreviations: SRI=severe respiratory insufficiency questionnaire, SGRQ= St. George's respiratory questionnaire, RAND-36= research and development short form 36 questionnaire, HAD= hospital anxiety and depression scale, ESS= Epworth sleepiness scale, FSS= fatigue severity scale, COPD= chronic obstructive pulmonary disease, ORRF= obesity related respiratory failure, NMD-CWD= neuromuscular or chest wall disease.

There was no difference between patient disease groups in perception of HMV measured through VAS scores and the patient ventilator asynchrony questionnaire (PVIQ).

#### 4.3.8.4 Relationship between patient ventilator asynchrony levels and health related quality of life measures with HMV therapy

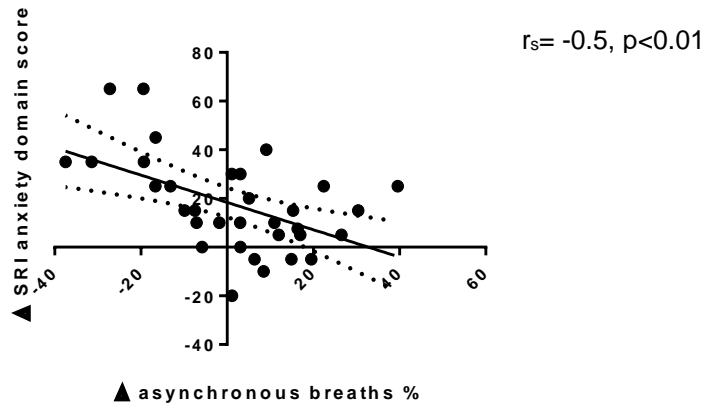
There was no correlation between PVA and HRQL questionnaires scores observed at initiation of HMV or 3 months post HMV therapy. No significant correlations were observed with the changes in HRQL measures using total SRI scores, RAND-36, HAD, ESS, FSS and changes in patient ventilator asynchrony levels. A weak correlation was observed with the changes in SGRQ scores and the amount of patient ventilator asynchrony ( $r_s = -0.42$ ,  $p = 0.02$ ). (Figure 50). A correlation was also observed in changes of anxiety domain of the SRI questionnaire and the amount of patient ventilator asynchrony ( $r_s = -0.50$ ,  $p < 0.01$ ). (Figure 51). This association did not remain using the changes in the anxiety domain of the HAD and the changes in PVA ( $r_s = 0.31$ ,  $p = 0.08$ ).

**Figure 48: The relationship between changes in the SGRQ scores and changes in patient ventilator asynchrony levels following 3 months of HMV therapy**



*Abbreviations:*  $\Delta$ SGRQ score- change in St. George's respiratory questionnaire score following 3 months of home mechanical ventilation therapy,  $\Delta$  asynchronous breaths- change in asynchronous breaths with 3 months of home mechanical ventilation therapy.

**Figure 49: The relationship between changes in the anxiety domain of the SRI questionnaire and changes in patient ventilator asynchrony levels following 3 months of HMV therapy**



*Abbreviations:*  $\Delta$  SRI anxiety domain score- change in the severe respiratory insufficiency questionnaire (anxiety domain) with 3 months of home mechanical ventilation,  $\Delta$  asynchronous breaths- change in asynchronous breaths with 3 months of home mechanical ventilation therapy.

The proportion of PVA at both initiation and 3 months post treatment did not correlate with patient reported synchronisation to the ventilator using a VAS scale ( $r_s = -0.01, p = 0.9$  and  $r_s = 0.03, p = 0.9$ ). 64% of patients were unable to correctly identify the dominant asynchrony occurring overnight when questioned the following morning.

#### **4.3.9 Nocturnal ventilator titration to set up HMV**

The number of ventilator parameter manipulations required by nursing staff and physicians prior to initial discharge was significantly greater in the physician led HMV set up group than the physiological led set up,  $p < 0.001$ . (Table 24). The majority of alterations to the ventilator required in the physiological group at baseline (60.6%) were to increase the EPAP levels to control of upper airway obstruction. The majority of manipulations required in the physician led group were to titrate pressure support and increase the levels of IPAP (70%).

**Table 24: Comparison of the number of ventilator alterations: comparison of the physician led HMV set up and the physiological led set up of HMV over the 3 months of HMV therapy**

Observation period	Physiological set up (n=17)	Physician led HMV set up (n=17)	p-value
<b>First night of HMV</b>	1.0 (0.0-3.5)	6.0 (3.0-12.0)	p<0.001
<b>Post first night to 3 months of HMV</b>	0.0 (0.0-3.0)	2.0 (0.0-4.5)	p=0.15
<b>Total ventilator manipulations over 3 months HMV</b>	0.0 (0.0-3.3)	4.0 (0.5-9.5)	p<0.001

*Abbreviations:* HMV-home mechanical ventilation.

#### 4.3.10 HMV set up length of hospital stay

Hospital length of stay was reduced by one day in the physiological set up HMV group compared to the physician led set up of HMV (Table 25).

**Table 25: Comparison of the length of hospital stay for initiation of HMV between the physician led HMV set up and the physiological set up of HMV**

	Physiological HMV set up (n=17)	Physician led HMV set up (n=17)	p-value
<b>Length of stay for HMV initiation (days)</b>	2 (2-2)	3 (2-3)	p=0.04

*Abbreviations:* HMV- home mechanical ventilation.

## **4.4 Discussion**

### **4.4.1 Main findings**

#### **Clinical**

This is the first pilot randomised trial to investigate the clinical effectiveness of physiological HMV set up, targeting neural respiratory drive, compared with standard physician led HMV set up. Although there was no between group difference in the primary outcome of daily ventilator adherence, there was shorter length of hospital admission for HMV set up as well as less requirement for ventilator setting alterations in the physiological set up group. In addition, all the patients tolerated physiological targeted set up of HMV. As there was no difference in ventilator adherence between the groups, it is not surprising that there were no differences observed in gas exchange and respiratory muscle unloading at 3 months between the intervention and control group.

#### **Physiological**

The data from this trial have shown a high prevalence patient-ventilator asynchrony during the initiation of HMV. Indeed, these data have demonstrated that almost a quarter of all breaths are asynchronous during set up of HMV. More importantly, these data have shown that there was no attenuation in the amount of PVA following 3 months of HMV therapy. Similarly to Carlucci *et al*, we have demonstrated that the proportion of PVA during HMV was not associated with a particular underlying specific disease group.(146) Furthermore, there was no association observed between the proportion of PVA during HMV and ventilator adherence, gas exchange, respiratory muscle unloading or patient perception of patient ventilator co-ordination.

#### 4.4.2 Critique of the Method

Due to practical constraints of a single clinical researcher (MR) conducting this RCT and performing the analysis, the scoring of the PVA could not be performed blinded to the intervention. Although every effort was made to ensure accurate reporting of the PVA consistent with the pre-defined definitions, there may be unintentional bias. However, when testing the reliability of the scoring method, adequate inter-observer agreement was achieved on traces reported in this study with a second scorer (SM) who was blinded to the intervention (Methods 2.10).

Measuring sEMGpara overnight is prone to signal disturbance during periods of patient movement introducing artefact. Severe episodes of PVA may result in patient arousal from sleep which often manifest in movement of the patient.(70) It is therefore possible that the proportions of PVA in this study are under-represented as these periods of severe asynchrony and patient movement were excluded from the analysis.

Although every effort was made to balance the groups in terms of disease group, age and body composition using standard minimisation techniques at randomisation, differences in neural respiratory drive were observed in the patients during self-ventilating trials both during the daytime and overnight. Indeed, these differences may represent different phenotypical characteristics between patients from within a similar disease group in terms of the respiratory load and capacity balance of the respiratory system. Those patients with higher neural drive overnight may have more severe sleep disordered breathing, whereas those with lower neural drive may have spent more of the night awake. As polysomnography was not used for all patients, we are not able to comment on this fully.

Despite the intention of improving PVA using a novel physiological biomarker of inspiratory effort (sEMGpara) to maximally unload the respiratory muscles, we were unable to demonstrate a reduction in PVA in the interventional arm. Currently, there is no definitive method known to enhance asynchrony and correction methods are likely to vary between disease groups and with the changing upper airway resistance observed between wake and sleep. We have adopted a pragmatic clinical approach to addressing PVA (See appendix 2 for sEMGpara set up protocol), which has major limitations in that the current manually titrated modification of the ventilator settings lacks a much needed dynamic approach, albeit there are more advanced automated ventilator technologies being

developed that could be expected control for PVA. As ventilatory support impacts on pulmonary mechanics and the pattern of breathing, PVA is a dynamic phenomenon that will change over time and hence there is a requirement to provide a technology that can both monitor PVA and well as modify the ventilator settings to reduce asynchrony. This is further likely to be affected by different sleep stages. Rapid eye movement sleep has been shown to be associated with reduced neural respiratory drive, which would be expected to reduce asynchrony as the mandatory pressure controlled ventilation becomes more prominent (147). The main target of using sEMGpara was to maximise respiratory muscle unloading and optimise ventilator set up as evidenced by a reduction in sEMGpara%max. However, reducing neural respiratory drive with increased levels of pressure support may have adverse impacts on the amount of asynchrony, in particular, ineffective efforts. (77, 148) Despite this, the proportion of ineffective efforts during the first night of HMV was actually lower in the physiological led set up group compared with the physician led group (7.0 (3.6-22.3)% vs. 14.1 (8.1-24.1)%).

PVA may also be related to the operating characteristics of the home mechanical ventilator (NIPPY 3+, B&D Electromedical, Stratford-upon-Avon, UK) used in this study. Despite optimising the ventilator triggering sensitivity during HMV set up, as shown by the greater trigger sensitivity in the physiological set up group, the proportion of PVA and type of PVA was similar in each group. The NIPPY 3+ has an inspiratory and expiratory flow trigger with a sensitivity scale of 0-10, with 10 being the most difficult. This scale is non-linear and information is not provided to the operator as to how each trigger setting alters the flow triggering threshold. The NIPPY 3+ also delivers positive pressure by a turbine and so despite the most sensitive trigger setting there is maybe an intrinsic delay between the detection of inspiratory flow and the blower output to deliver ventilator support impacting on delayed inspiratory triggering and ineffective efforts. Flow cycle triggering into expiration can also adversely impact on the interaction between the patient and the ventilator. Particularly in obstructive airways disease when flow rates may reach a lower peak value and decrease slowly following inspiration.(13) An extended inspiratory time in COPD may result in breath stacking, hyperinflation and further increase difficulties in triggering the ventilator.(13) Furthermore, flow expiratory triggers have been associated with more PVA than a time cycled mode of switching to expiration.(13) This study may therefore have been limited by the operating characteristics of the ventilator. As only one

type of home mechanical ventilator was used to provide assisted ventilation in this study. The proportion of PVA identified in this study may not apply to other ventilators.

In this study, as with many clinical studies, we were not able to measure and quantify the level of mask leak that would have contributed to PVA, in particular cycling PVA. The NIPPY3+ (B&D Electromedical, Stratford-upon-Avon, UK) similar to other home mechanical ventilators does not provide accurate leak measurement as recently shown by Contal *et al.*(149) Despite our best efforts to minimise leak with time spent carefully fitting the mask interface, it is wholly possible that mask leak would have increased the proportion of PVA observed despite optimal setting of the ventilator.

Lastly, the physiological optimisation of the ventilator settings was undertaken in the awake state but HMV is used during sleep. The titration of the ventilator settings may therefore have underestimated the pressures required to optimise purely sleep associated phenomenon such as upper airways obstruction. Where further titration was required in the physiological set up group this was to enhance EPAP settings to alleviate this. From our experience, a better estimate of the EPAP required based on baseline investigations during sleep could be employed for future studies using this technique.

### **Methods of assessment**

The effectiveness of the ventilator setting was assessed by the physician in charge of the patient's care having reviewed the patient's clinical history, examination and investigations, including the nocturnal oximetry and capnography measurements. The current gold standard assessment of ventilator titration includes extended polysomnography to assess sleep quality and confirm sleep staging. However, this is not routine practice in the UK. As the primary goal of HMV is to manage chronic respiratory failure, previous studies have shown that overnight monitoring of SpO<sub>2</sub> and TcCO<sub>2</sub> are a clinical useful method to titrate HMV.(150, 151)

Throughout the overnight studies, the measurement of flow, and therefore mask leak, was not possible for two main reasons. Firstly, as the pneumotachograph is heated and thus it cannot be left unattended and continuous observation overnight by the research team at the bedside was of

concern as this would impact on sleep quality. Secondly, the Hans-Rudolph pneumotachograph we have previously used in our studies, needs to be supported overnight as the weight pulls on the mask interface resulting in unintentional leak. It was impossible to support the pneumotachograph at the mask and allow the patient to move freely in the bed overnight plus have adequate sleep quality. Spontaneous breathing was measured by nasal cannula and ventilator delivered pressure was measured at the mask. The measurement of inspiratory pressure change at the nasal cannula has been validated against face mask pneumotachography.(152)

### **Patient ventilator asynchrony**

In this trial, we were not able to significantly reduce PVA overnight using a novel physiological approach that was targeted to maximise respiratory muscle unloading and optimise the ventilator settings. As discussed above, this supports the concept that PVA is a dynamic process that requires continuous monitoring and adjustment of the ventilator settings to adapt to changes in pulmonary mechanics and sleep stage. A previous observational study that employed physiological set up of the ventilator during wakefulness did not reduce PVA during sleep, although some improvement in ineffective efforts overnight was achieved by a physiological titration of EPAP.(75)

Many of the previous studies have investigated the prevalence of PVA in an acute setting in patients receiving invasive ventilation. Few studies, prior to the current study, have focussed on those in chronic respiratory failure requiring HMV. Furthermore, there are even fewer studies that have considered all types of PVA (cycling and triggering) as part of extended overnight monitoring. (77, 89, 93) Thille *et al.* reported that 24% of invasively ventilated patients exhibited severe levels of asynchrony (>10% of all ventilator breaths delivered) when commencing assisted ventilation.(77) Vignaux *et al.* demonstrated that 43% of patients on non-invasive ventilation for acute respiratory failure had severe PVA.(89) In contrast, Carreaux *et al.* reported that few patients had severe PVA on HMV whereas Carlucci *et al.* observed 30% patient on HMV had severe PVA.(80) In this trial, we observed that severe PVA affected 88% of the patients at initiation of HMV and 94% of patients following 3 months of HMV, using the standard 10% asynchrony index cut off. The higher prevalence in the current study may be related to the longer observation period as all of these previous studies

investigated patient-ventilator interaction over a maximum of 30 minutes and it is unclear if this included any periods of sleep.

The current cut off level of severe asynchrony was based on work by Vitacca *et al.* that investigated ineffective efforts only over a minute under different levels of pressure support in patients weaning from invasive ventilation. This therefore has limited usefulness in the HMV group receiving a fixed level of pressure support overnight. Furthermore, ineffective efforts were measured by the assessment of the ventilator waveform, which has since been shown to under report PVA particularly when PVA has a high prevalence.(153) This questions both the reliability and applicability of the 10% asynchrony index in the HMV group.

### **Type of patient ventilator asynchrony**

Similarly to previous studies, we have confirmed ineffective efforts are the most common type of PVA in patients receiving HMV affecting approximately 10% of breaths at initiation and 6% of breaths at 3 months. Auto-triggering was the next most frequent type of PVA affecting 3% of breaths during HMV set up and but with a significant increase to 6% of breaths at 3 months. Auto-triggering has been related to mask leak and so this increase may relate to increase in mask leak due to wear and tear of the mask seal over time.(154) All other asynchronous events affected <2% of breaths at both HMV initiation and 3 months of HMV use.

In this trial, we have standardised PVA definitions to facilitate reproducible assessments. There has been ambiguity in the literature regarding the current PVA nomenclature. We have based the current definitions on those used defined by Vignaux *et al.*(89) We have further clarified the difference between auto-triggering, which represents a single non-triggered breath, and auto-cycling, which reports more than 3 non-triggered breaths in a row separated by less than 1 second. This has previously been described as the delivery of non-triggered breaths over and above the back-up rate associated with high trigger sensitivity.(155) We have also observed an infrequent type of PVA with HMV that was previously not defined but represents a single sustained patient inspiratory effort that triggers 3 or more ventilator delivered breaths before the patient exhales. We have termed this as multiple triggering. Multiple triggering was observed in 23% of patients at initiation of HMV and 30% of patients at 3 months, but affected < 0.1% of breaths overall at each assessment. It therefore remains unclear as to whether its impact on patient ventilator interaction is of clinical significance.

### **HMV Adherence**

Adherence to HMV at 3 months in the physiological led HMV set up was similar to the physician led HMV set up with both groups achieving a mean daily adherence of more than 4 hours. NIV use has been shown to correlate with reduction in daytime PaCO<sub>2</sub> with a nocturnal adherence of 4 hours required to control daytime hypercapnia in obese, NMD-CWD and possibly COPD patients.(39, 56, 156) HMV use of greater than 4 hours also led to an increase in physical activity and weight loss in obese patients and a reduction the Epworth sleep score in NMD-CWD patients at 3 months.

There was no relationship observed between the PVA and hours of adherence to HMV in the current trial. Although other studies have reported that severe asynchrony was associated with a poorer tolerance of non-invasive ventilation, these studies were performed in the acute setting, over a 30 minute period and no long term measurements of adherence have been reported.(89, 146) Adherence to ventilation may be very variable and impacted by commonly described disadvantages of HMV, such as claustrophobia, anxiety, requirement for patient motivation, inconvenience, gastric distension, noise or interface discomfort.(157-160) Although every attention was given to optimise the interface for all patients in this trial, 41.2% of patients reported persistent interface discomfort on direct questioning at 3 months. Patients in this study also reported increased levels of anxiety, as measured by the anxiety component of both the HAD and the SRI questionnaires, at initiation. Anxiety levels are important factor determining quality of life in patients on HMV and have been related to increased severity of pulmonary disease in COPD patients.(102) Ultimately, it is likely that patient adherence to HMV is multi-factorial and a combination of all of these factors play a role in the individual patient.

### **Gas exchange**

This pilot randomised controlled trial demonstrated that physiological HMV set up had similar physiological efficacy, in terms of gas exchange at 3 months, to the physician led HMV set up. This was shown as a reduction in daytime PaCO<sub>2</sub> and nocturnal mean TcCO<sub>2</sub> with an increase in daytime PaO<sub>2</sub> and nocturnal mean SpO<sub>2</sub> levels in both the intervention and control groups. These improvements in gas exchange were not disease specific, but realised in all patient groups. Furthermore, there was no relationship demonstrated between PVA and gas exchange. Specifically,

there was no association between total PVA and the time spent with oxygen saturations < 90% overnight. There was a weak relationship between ineffective efforts and the time spent with oxygen saturations <90% but this was only observed during the initiation of HMV ( $r_s=0.33$ ,  $p=0.04$ ), which was a similar finding to that of Fanfulla *et al.* ( $r= 0.39$ ).<sup>(76)</sup>

Home mechanical ventilators have improved performance characteristics over the last decade and are commonly used in pressure support mode with a set back up rate as in our trial. Interestingly, there is no mention of a back-up rate being used overnight in the study by Fanfulla *et al.* that reported the relationship between ineffective efforts and nocturnal oxygen saturations.<sup>(76)</sup> It may be hypothesised that as long as the patient receives a sufficient back-up rate from the ventilator then gas exchange will occur regardless of patient ventilator synchronisation. In support of our findings, and more recently, Bertrand *et al.* compared neurally adjusted ventilator assist (NAVA) with pressure support ventilation (PSV) in patients with acute respiratory failure with a respiratory rate above 25 breaths per minute requiring non-invasive ventilation.<sup>(141)</sup> This study demonstrated that the use of NAVA led to a reduction in severe PVA, however, no improvement in gas exchange was reported over the 30 minute assessment period.<sup>(141)</sup> Furthermore, there was no association reported between PVA and nocturnal TcCO<sub>2</sub> and SpO<sub>2</sub> in stable patients with obesity hypoventilation receiving HMV overnight.<sup>(70)</sup>

### **Respiratory muscle unloading**

This is the first study to demonstrate non-invasive evidence of respiratory muscle unloading with HMV using sEMGpara%max. Both the physiological HMV set up and the physician led set up achieved respiratory muscle unloading after the first night of HMV and at 3 months post initiation of HMV therapy. No significant difference was observed between the proportion of respiratory muscle unloading achieved at 3 months with either approach. This may have been explained, in part, by the differing levels of neural respiratory drive demonstrated by the two groups during the self-ventilating trials prior to starting HMV. Despite randomising patients by minimisation on the basis of lung function, age and body composition in an attempt to evenly distribute the different patient disease groups, when examining neural respiratory drive, patients in the physiological led HMV set up demonstrated an increase in sEMGpara%max during nocturnal ventilation. The same was not seen

in the physician led HMV set up group and may represent phenotypical differences within disease categories in terms of pulmonary mechanics, patient reserve and nocturnal respiratory muscle loading between the two groups. Despite the differences in neural drive characteristics post the first night of HMV, there was a median reduction in sEMGpara%max of -4.7 (-8.8 to -0.7)% in the physiological led set up compared to -1.7 (-3.2 to +0.1) in the physician led set up which approached significance ( $p=0.06$ ).

Unlike previous studies, we did not demonstrate a relationship between respiratory muscle loading and PVA.(8, 86, 88) These studies investigated respiratory muscle loading in acutely unwell patients or patients recovering from acute illness who were fully dependent on receiving invasive ventilation. A similar effect on respiratory muscle unloading may not occur in patients requiring nocturnal non-invasive ventilation only. Furthermore, it is not reported in these studies if the patients were investigated whilst asleep. In the study by Leung *et al.* patients were asked to rate their sensation of dyspnoea using a Borg score strongly supporting that they were awake. Sleep, and different stages of sleep, is known to reduce neural respiratory drive, in particular, during rapid eye movement sleep and therefore the effects of an increase in respiratory muscle loading from an asynchronous event may not be so easily observed.(161, 162)

### **Health related quality of life**

Health related quality of life (HRQL) improvements are fundamental to successful HMV set up as one of its main clinical goals is for symptom control in patients with progressive disease. Over 3 months of HMV therapy, improvements were observed in HRQL measures, including the SRI sum score, RAND-36 sum score, HAD score and ESS. A statistically significant improvement was not observed in the SGRQ questionnaire however in minimally clinically importance difference for improvement was achieved. Our study supports the previous finding that HMV improves quality of life in patients with COPD, obesity, NMD and CWD.(40, 51, 67, 133, 163, 164). However, in this study no disease group benefited significantly more than another following 3 months of HMV therapy. These improvements in health related quality of life, patient comfort and patient perception of PVA were similar between patients set up on HMV using protocol led and the physician led HMV set up at 3 months. Of interest, though not statistically significant patients in the physiological-led set up did report improved patient

ventilator co-ordination following the first night of HMV, although this benefit was lost over the 3 months of therapy. It is unclear whether this represents a contemporaneous effect of the intervention.

The impact of patient ventilator asynchrony on health related quality of life from longitudinal studies has never been addressed. There is, however, some limited evidence to suggest that patient ventilator asynchrony in the form of ineffective efforts adversely impacts on patient comfort and dyspnoea on ventilation.(89, 90, 135, 146) In the current trial, we could not identify any significant correlation between PVA and patient perception of comfort whilst receiving HMV. None of the previous studies were performed on elective patients using HMV, outside of an acute setting, where anxiety levels and the perception of comfort and dyspnoea may be different. These studies also assessed patients whilst awake and during ventilator therapy as opposed to recall post nocturnal ventilation, which may also explain this difference. We could not identify a difference in comfort scores using a severity cut off for asynchrony levels, but this may reflect the high prevalence of PVA as a majority of patients had PVA affecting >10% breaths.

Of interest, we observed an inverse correlation between the anxiety component of the SRI questionnaire following 3 months of HMV and the proportion of PVA. This may suggest that patients perceive PVA overnight but report this as anxiety as they struggle to describe the patient ventilator asynchrony. A component question of the SRI anxiety score details patient anxiety at night asking the patient to rate if they are 'afraid of having breathing difficulties at night', which may explain an association with PVA. Furthermore, these data suggest that if patient anxiety levels fail to improve a comprehensive physiological overnight assessment may be warranted to elucidate any issues with PVA.

An inverse relationship between PVA frequency and improvement in the SGRQ was observed over 3 months of HMV therapy. Although validated in obstructive airways disease, this association may be apparent as the largest disease group studied were those with COPD. Examining the SGRQ more closely there are questions again related to anxiety levels and sleep disturbance such as 'my cough or breathing disturbs my sleep' and 'I get afraid or panic when I cannot get my breath' which may manifest as patient perception of PVA. This warrants further investigation.

### **Hospital length of stay during HMV set up**

Hospital length of stay was reduced in patients who were initiated on HMV using physiological led set up. In addition, there was reduced requirement of ventilator modifications required in this group prior to hospital discharge. These observations would support the suggestion that physiological led HMV set may have additional cost benefits. In view that the physiological led set up involved a daytime set up with a majority of patients requiring limited modification of the settings suggests that this approach to initiating HMV could be employed in future studies in the outpatient setting leading to further cost benefits.

### **4.4.3 Clinical significance of the findings**

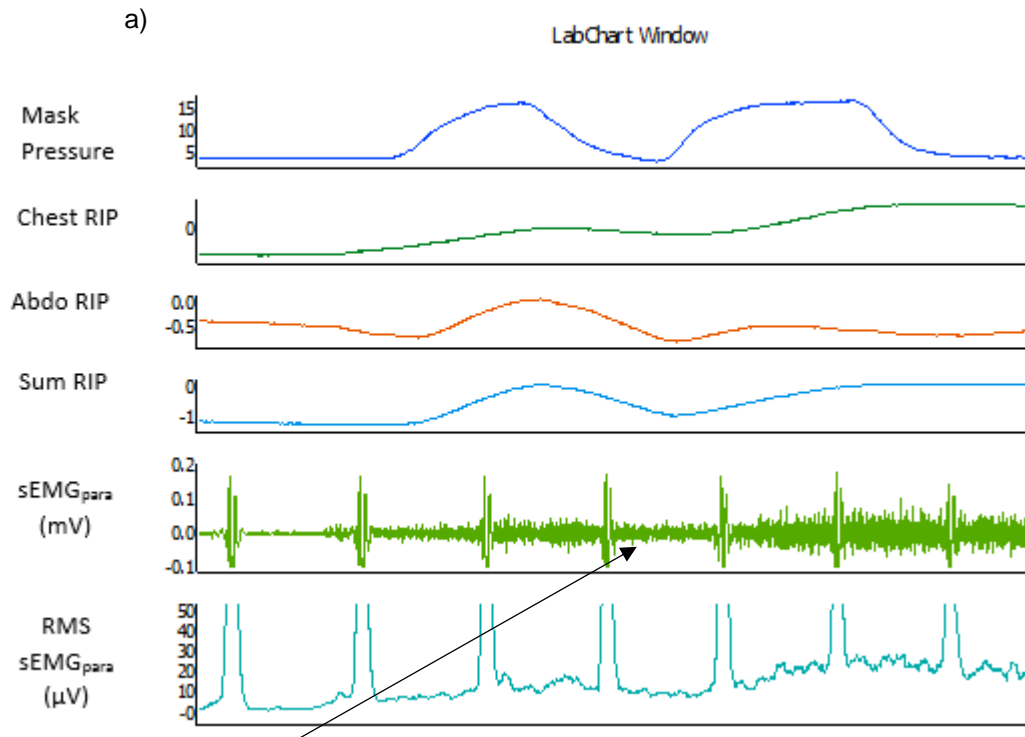
The current trial is the first to assess PVA overnight at initiation of HMV and at 3 months post initiation of HMV therapy. We have demonstrated that the high prevalence of PVA at the initiation of HMV is sustained at 3 months. No association between the levels of PVA and patient adherence to HMV therapy could be demonstrated. However, we have also shown that despite the high proportion of PVA, there is limited adverse impact on respiratory muscle unloading, gas exchange, quality of life or ventilator adherence. There may be an association with the patient's perception of anxiety surrounding the use of HMV, although this must be confirmed.

We have demonstrated that using the neural respiratory drive, measured from the second intercostal space parasternal muscle, in combination with thoraco-abdominal movement and mask pressure we can non-invasively identify and categorise PVA at the bedside. The use of the neural respiratory drive can guide the physician to diagnose the different types of PVA, which facilitates a comprehensive understanding of patient ventilator interaction and provides information of the possible cause of the PVA. For example, double triggering can occur when premature cycling affects the first ventilator delivered breath and the second ventilator breath is generated because of ongoing inspiratory effort from the patient. Alternatively, double triggering may occur due to an auto-triggered breath occurring immediately post a normally triggered breath (as in our definition). The underlying cause of PVA cannot be detected by the measurement of thoraco-abdominal movement alone as the onset of inspiratory effort is unclear but the additional measurement neural respiratory drive facilitates the diagnosis between them and enables appropriate correction. (Figure 52). Similarly, ineffective efforts

may be underestimated in current practice where the chest and abdominal bands are used to detect inspiratory efforts. In particular, in neuromuscular patients, we have observed low levels of neural respiratory drive representing an ineffective effort that did not lead chest wall excursion. (Figure 53). A similar observation was noticed by Luo *et al.* when measuring diaphragm EMG during sleep and identified ongoing diaphragm activation without thoraco-abdominal movement. (109) These authors concluded that the presence of patient inspiratory drive confirming obstructive sleep apnoea was, in fact, present in a third of cases that were otherwise diagnosed as central sleep apnoea when relying on thoraco-abdominal movement.(109)

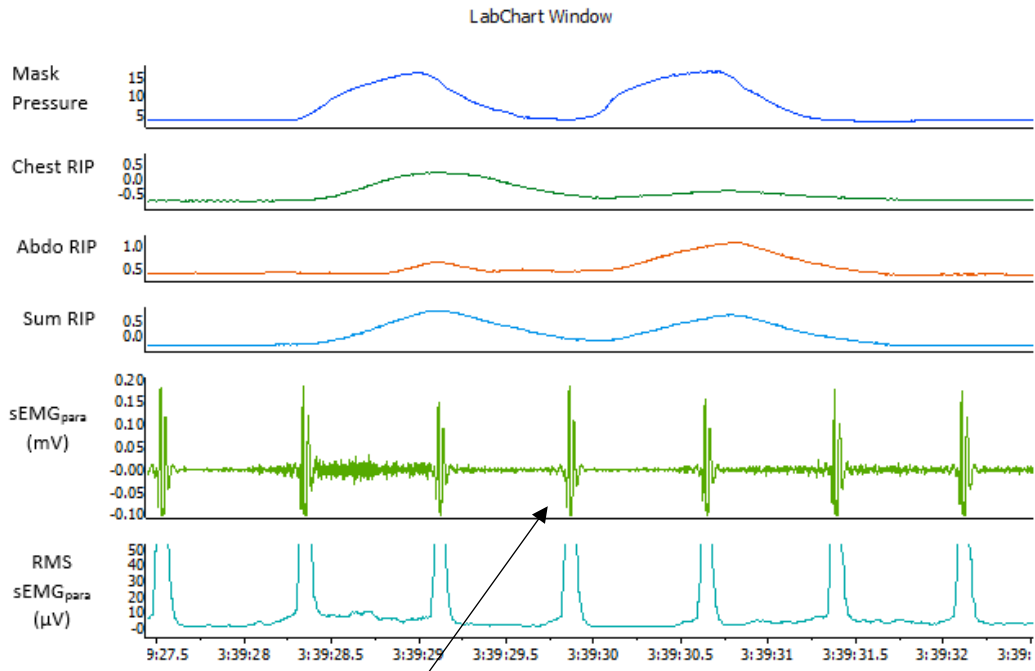
However, detailed assessment of PVA is currently manually scored and so very labour intensive. It is clear from the data in this study that the impact of PVA is limited in an HMV setting and not required for every patient at initiation. In its current form PVA assessment should be rationed to patients struggling to adhere to HMV, those adversely impacted by of PVAs and those that remain very anxious of using HMV with no other clear explanation post a trial of HMV therapy. Future work should concentrate on an automated assessment if PVA detection is to be used in routine clinical practice.

**Figure 50: Two examples of double triggering occurring when considering only the RIP chest and abdominal bands related to two different phenomenon a) A prematurely cycled breath with ongoing patient inspiratory effort to trigger a second ventilator delivered breath, b) A patient triggered breath followed by an non-patient triggered (auto-triggered) breath**



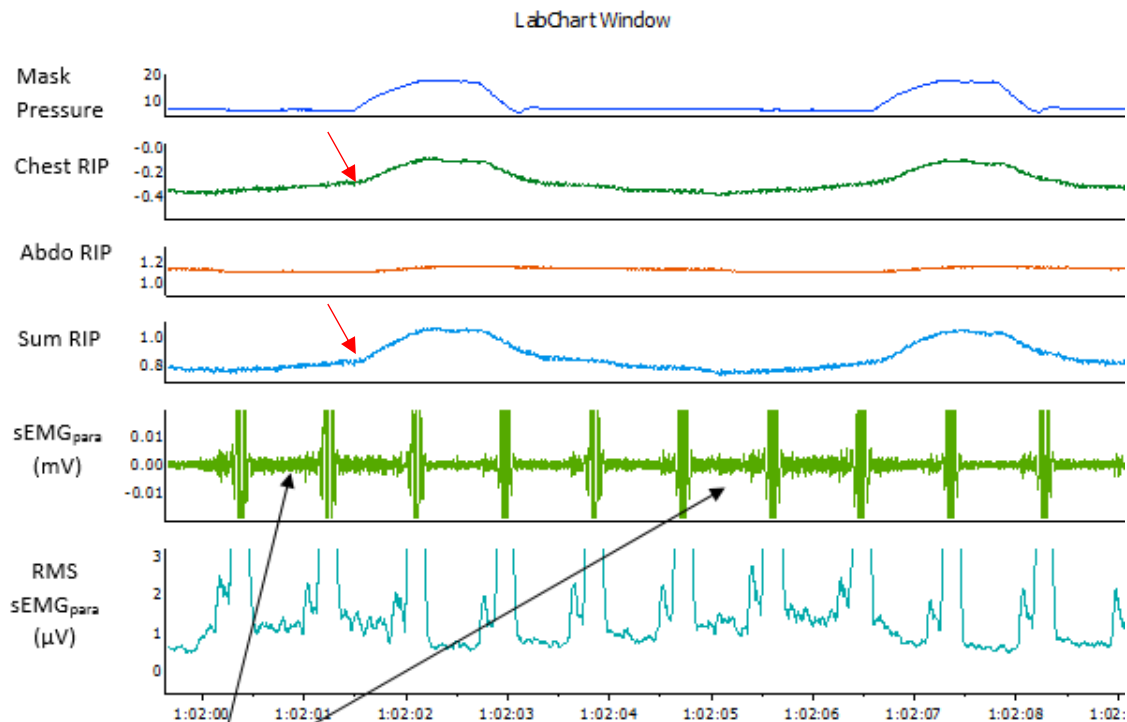
Ongoing patient inspiratory effort

b)



No patient inspiratory effort

**Figure 51: Two inspiratory efforts apparent with sEMGpara but not with RIP chest and abdominal bands each followed by a ventilator triggered breath (obtained from a Duchenne muscular dystrophy patient)**



sEMG<sub>para</sub> activity consistent with inspiratory effort without chest or abdo RIP movement



Represents the point at which inspiratory effort is apparent examining the chest and sum RIP bands and confirms that there is not an

### CLINICAL IMPACT

We have shown that measuring sEMG<sub>para</sub> is a non-invasive assessment of neural respiratory drive that can be used to monitor respiratory muscle unloading at the bedside whilst using HMV. This signal could be used to guide the physician to the optimal ventilator settings for the individual patient. Carteaux *et al.* demonstrated benefits of bedside targeting respiratory muscle unloading to assist with weaning from invasive ventilation.(165) A similar approach could be taken when initiating HMV.

Although physiological led set up did not improve upon an expert tertiary centre physician led set up in terms of patient outcomes, significantly less ventilator manipulation was required during initiation which resulted in a shorter length of stay. With the increasing demands for HMV, this technique may

be particularly useful to assist physicians in district general hospitals who are less familiar with HMV set up to provide a local service.

## **4.5 Conclusion**

This pilot randomised control demonstrated that a physiological led set up of HMV, using neural respiratory drive to optimise ventilator set up, has similar efficacy to an expert physician led set up of HMV in terms of ventilator adherence, gas exchange, respiratory muscle unloading and health related quality of life improvements at 3 months. However, the physiological led HMV set up resulted in fewer ventilator setting modification during overnight titration with a reduced length of inpatient stay for HMV set up. These advantages were achieved without a reduction in the frequency of patient ventilator asynchrony during HMV and indeed PVA was high at baseline and remained high after 3 months of HMV therapy. Of clinical importance, there was no relationship observed between PVA and clinical outcomes such as ventilator adherence, gas exchange, overnight respiratory muscle unloading and patient perception of ventilator comfort. These current data suggest that the elimination of PVA may not be required to successfully set-up HMV, but that a clear understanding of the physiological effect of HMV is required to minimise ventilator modification and admission length of stay during HMV set up.

# Chapter 5 Impact of Patient Ventilator Asynchrony on Sleep

## Quality

### 5.1 Introduction

Sleep disordered breathing is common in patients with chronic respiratory failure. Respiratory failure results from an imbalance between the loads placed upon the respiratory system and its capacity to compensate for that load. To balance the load on the respiratory system in patients with respiratory disease, neural respiratory drive is elevated to activate and recruit muscle to increase the operational capacity from the respiratory muscle pump. Overnight, the natural fall in neural respiratory drive during sleep, particularly in rapid eye movement (REM) sleep, exacerbates the respiratory muscle load-capacity imbalance. This occurs in combination with muscle hypotonia of the upper airway musculature and a blunted hypercapnic ventilatory response predisposing to alveolar hypoventilation and respiratory failure.(166, 167) Sleep disordered breathing therefore may develop as an early sign of chronic respiratory failure leading to poor sleep quality and daytime somnolence.(168, 169)

The impact of long-term sleep disruption related to sleep disordered breathing on patients with chronic respiratory failure is unclear. Studies in healthy subjects and animal models have shown that sleep disruption adversely impacts on cellular and humoral immunity, oxygen consumption and carbon dioxide production, respiratory muscle endurance, hypercapnic ventilatory responses and thermoregulation. (170-172)

Effective nocturnal non-invasive ventilation reduces the work of breathing, alleviates upper airways obstruction and assists the respiratory muscle pump to improve alveolar hypoventilation and gas exchange. Correcting sleep disordered breathing with non-invasive mechanical ventilation has shown to significantly improve both nocturnal ventilation and sleep quality in patients with chest wall deformity at 12 months.(173)

However, poor sleep quality has still been reported during the use of both invasive mechanical and non-invasive ventilation although the aetiology of this is not fully understood.(75, 91, 174) In a study by Bergbom- Engberg *et al.* assessing patient's experiences of mechanical ventilation, 35% retrospectively described significant sleep disruption.(175) 30% reported symptoms of 'agony/panic' during mechanical ventilation that was associated with difficulties in synchronising the patients

breathing to the ventilator.(175) This has led to the suggestion that patient ventilator asynchrony may be directly related with arousals and awakenings resulting in persistent sleep disruption. Previous studies that examined patients with chronic respiratory failure receiving home mechanical ventilation (HMV), demonstrated a relationship between increased PVA and poor sleep quality, defined as greater sleep fragmentation with reduced stage 3 and REM sleep.(70, 75, 176) Bosma *et al.* compared proportional assist ventilation to pressure support ventilation in patients weaning from mechanical ventilation and reported that proportional assist ventilation improved sleep disruption as a consequence of a reduction in PVA.(91)

There are no longitudinal studies investigating the relationship between the patient ventilator asynchrony and sleep quality in patients with chronic respiratory failure receiving HMV. We hypothesised that (1) patient ventilator asynchrony negatively impacts on sleep quality and (2) patient ventilator asynchrony induced sleep disruption improves with time spent on HMV.

## **5.2 Methods**

### **5.2.1 Patients**

This study was approved by the local ethics committee and all patients provided written informed consent.

10 patients with chronic respiratory failure (7 males) recruited to the randomised controlled trial, described in Chapter 4, agreed to additional polysomnography assessment overnight. Chronic respiratory failure was defined as patients with evidence of daytime PaCO<sub>2</sub> greater than 6kPa with a normal arterial blood pH range of 7.35-7.45.

The inclusion and exclusion criteria are described in Chapter 4 1.2.

### **5.2.2 HMV set-up**

All patients were admitted for nocturnal set up and titration of HMV (NIPPY3+ ventilator; B&D Electromedical, Stratford-upon-Avon, UK). Two patients were initiated on HMV using a physician led nocturnal titration set up protocolised according to their underlying pathophysiological condition (described in Appendix 2) as is standard practice in our unit. Eight patients were initiated on HMV

using a physiological set-up to address patient ventilator asynchrony and optimise respiratory muscle unloading (described in detail in Chapter 4). As there were no between group differences observed in PVA and gas exchange, the patients from both groups were combined as a single cohort. All patients received a pressure support mode with a fixed back up rate set at 2 breaths below their resting breathing rate.

### **5.2.3 Nocturnal polygraphy assessment**

Respiratory polygraphy was performed overnight to include assessments of sEMGpara, RIP and mask pressure (as described in Chapter 4). Each breath during a 2 minute epoch, measured every 10 minutes, over seven hours (or as long as the patient slept) was analysed for synchronisation between the patient and ventilator according to our standardised definitions. Signals with movement artefact were excluded and the closest 2 minute epoch that was artefact free was assessed. Pulse oximetry and transcutaneous capnography measurements (TOSCA 500, Radiometer, Crawley, West Sussex, UK) were used to assess the adequacy of nocturnal ventilation. Assessments were performed overnight at both the initiation of HMV and post 3 months of HMV therapy.

sEMGpara, respiratory inductance plethysmography and mask pressure data were recorded on LabChart v7.3 software (AD Instruments Ltd, Oxford, UK) and saved on a password protected DELL desktop computer (Dell Corporation Limited, Bracknell, UK). Analysis of anonymised data was then performed offline on a password protected HP laptop (Hewlett-Packard Ltd, Bracknell, UK).

### **5.2.4 Sleep analysis**

Sleep was evaluated by limited polysomnography (PSG) using Alice 5<sup>®</sup> (Respironics<sup>®</sup>, Murrysville, PA, USA), as described in Chapter 2, during both the first night initiation of HMV and at 3 months post HMV therapy. All PSG recordings were scored manually in 30 second epochs both by myself and independently analysed by an expert sleep technician (ID) blinded to the respiratory polygraphy results. The PSG results following expert analysis were used in this study. (The levels of agreement between myself and the sleep technicians scoring 10 PSG studies can be found in Appendix 5). Sleep stages and arousals were scored in accordance to the American sleep medicine manual for the

scoring of sleep and associated events: rules, terminology and technical specification (2007).(117)  
Sleep and respiratory events scored with standard terminology are described in Chapter 2 (2.10.3).  
Terminology to explain our definitions of sleep disruption related to PVA are described below:

Arousal index ( $AI_{psg}$ ) was defined as the number of electroencephalogram (EEG) identified arousals from sleep lasting greater than 3 seconds that occurred per hour from full PSG analysis.

Arousal index ( $AI_{total}$ ) was defined as the calculated arousal index per hour incorporating only the 2 minute epochs that were screened for PVA throughout the overnight study.

$PVA_{wake}$  index was defined as the number of patient ventilator asynchrony events occurring per hour of wakefulness calculated from the 2 minute epochs.

$PVA_{sleep}$  index was defined as the number of patient ventilator asynchrony events occurring per hour of sleep calculated from the 2 minute epochs.

Patient ventilator asynchrony arousal index ( $AI_{pva}$ ) was defined as the number of patient ventilator asynchronous events that preceded an arousal within 3 seconds per hour of sleep overnight calculated from the 2 minute epoch assessments,

### **5.2.5 Integrating polysomnography and respiratory polygraphy: electroencephalogram and parasternal electromyogram**

To synchronise the analysis of overnight PSG from the Alice 5<sup>®</sup> equipment (Respironics<sup>®</sup>, Murrysville, PA, USA) and respiratory polygraphy recorded on to LabChart v7.3 (AD Instruments, Ltd, Oxford, UK) we applied two sets of abdominal and chest RIP bands. A maximal inspiratory manoeuvre was performed by the patient as part of the PSG calibration at the start of the overnight recording and at the end of the night study. From these assessments we could accurately match the configuration of the RIP bands from the two systems. We did not observe a discrepancy in the computer clocks over a night of recording using our computing systems but this was verified for each individual study.

Post manual scoring of the respiratory polygraphy in 2 minute epochs every 10 minutes overnight, the corresponding PSG epochs were manually compared to identify the stages of sleep patients were in

when PVA occurred. The frequency of arousals occurring during the 2 minute epoch respiratory polygraphy assessments was reported and PVA events preceding an arousal were identified.

### **5.3 Statistical Analysis**

Anthropometric data, were normally distributed and are presented as mean and standard deviation. Otherwise, non-parametric tests were performed, given the small number of patients. Comparisons between disease groups were descriptive only. Ventilator settings and sleep quality measures were expressed as medians (interquartile range) and compared over time, using the Wilcoxon-matched pairs test. Comparisons of PVA levels in the same patient between different sleep stages were performed with a repeated measures Friedman test. The frequency of PVAs occurring in different sleep levels and leading to arousals were compared using a Kruskal-Wallis test. Finally, correlations between PVAs and sleep efficiency measures were performed with a Spearman correlation. For all analyses, a p-value <0.05 was considered statistically significant.

### **5.4 Results**

Of the 10 patients recruited, 1 patients had chronic obstructive pulmonary disease (COPD), 2 patients had obesity related respiratory failure (ORRF), 3 patients had overlap syndrome (COPD with obstructive sleep apnoea (OSA)), 2 patients had neuromuscular disease (NMD) and 2 patients had NMD with OSA. Patient characteristics are described in detail in Table 26.

**Table 26: Patient baseline characteristics**

No. (n)	Disease Group	Phys set-up (Y/N)	Age yrs	Sex (M/F)	BMI kg/m <sup>2</sup>	FEV <sub>1</sub> % predicted	FVC% ratio (%)	FEV <sub>1</sub> /FVC
1	COPD/OSA	Y	61	F	41.6	35.0	83.7	35.0
2	COPD/OSA	Y	68	M	26.8	19.0	31.8	46.2
3	OHS/OSA	Y	42	M	37.2	81.5	88.7	75.3
4	OHS	N	84	M	34.7	35.8	36.2	72.1
5	COPD/OSA	Y	46	M	40.5	30.6	43.9	57.6
6	COPD	Y	59	F	16.9	37.8	94.6	33.3
7	NMD/OSA	Y	32	M	37.1	23.4	21.1	96.2
8	NMD/OSA	Y	69	F	39.1	48.9	54.7	73.2
9	NMD	N	41	M	20.3	12.3	12.1	89.0
10	NMD	Y	21	M	16.8	20.1	17.8	98.7
Mean			52		31.1	34.4	48.5	67.7
SD			±19		±9.9	±19.7	±30.7	±23.9

*Abbreviations:* Phys-Physiological led set-up of ventilation (interventional arm) COPD-chronic obstructive pulmonary disease, OHS-obesity hypoventilation syndrome, OSA-obstructive sleep apnoea, NMD-neuromuscular disease, BMI- body mass index, FEV<sub>1</sub>- forced expired volume in 1 second, FVC- forced vital capacity, SD-standard deviation, Y=yes, N=no, yrs-years, M-male, F-female, kg/m<sup>2</sup>-kilograms per metre squared.

As expected, patients with obesity related respiratory failure and/or obstructive sleep apnoea had higher levels of expiratory positive airway pressure (EPAP) than non-obese patients (11 (7-13) cmH<sub>2</sub>O and 4 (3-4) cmH<sub>2</sub>O, respectively). Pressure support levels at initiation of HMV were similar between the disease groups with COPD patients receiving 18 (14-20) cmH<sub>2</sub>O, ORRF patients 17 (12-22) cmH<sub>2</sub>O and NMD patients 18 (16-21) cmH<sub>2</sub>O. Back up rate was also similar between the disease groups with COPD patients receiving 14 (13-16) breaths per minute, ORRF patients 14 (14-14) breaths per minute and NMD patients 14 (14-16) breaths per minute. Only patients receiving physiological led set up of HMV had changes to the ventilator trigger settings. The most frequent change in ventilator settings in this group was a reduction inspiratory trigger sensitivity to address ineffective ventilator triggering. Inspiratory trigger was slightly more sensitive in patients with COPD and NMD than ORRF patients (3(2-4) and 3(2-4) vs. 4(4-4), respectively). The expiratory trigger was less sensitive in ORRF patients than COPD patients and NMD patients (7 (4-10) vs 4(2-4) and 5 (3-6), respectively) but this was led by a single patient with a high expiratory trigger of 10. (Table 27)

**Table 27: Ventilator settings at initiation and 3 months post HMV**

No.	First night NIV					3 months post NIV therapy				
	IPAP (cmH <sub>2</sub> O)	EPAP (cmH <sub>2</sub> O)	BUR (/min)	Trig <sub>insp</sub> (0-10)	Trig <sub>exp</sub> (0-10)	IPAP (cmH <sub>2</sub> O)	EPAP (cmH <sub>2</sub> O)	BUR (/min)	Trig <sub>insp</sub> (0-10)	Trig <sub>exp</sub> (0-10)
1	30	12	14	2	4	30	12	14	2	4
2	25	5	14	3	1	27	7	14	3	1
3	24	12	14	4	10	n/a				
4	25	3	14	4	4	25	3	14	4	4
5	32	14	16	4	4	30	10	16	4	4
6	16	4	12	3	4	16	4	12	3	4
7	28	7	14	3	3	28	8	18	3	3
8	26	9	14	3	6	26	12	14	3	6
9	22	3	16	4	4	24	3	16	4	4
10	20	4	14	2	5	16	4	14	2	5
Median	25	6	14	3	4	26	6	14	3	4
IQR	(22-30)	(4-12)	(14-15)	(3-4)	(4-5)	(20-29)	(4-11)	(14-16)	(3-4)	(4-5)

*Abbreviations:* IPAP= inspiratory positive airways pressure, EPAP= expiratory positive airway pressure, BUR= mandatory back up breath rate, Trig<sub>insp</sub>= Inspiratory trigger setting, Trig<sub>exp</sub>= Expiratory trigger setting, n/a= not applicable (patient failed to attend follow up 3 month study), IQR= Interquartile range.

There was no difference in ventilator settings observed between initiation of HMV and 3 months post initiation of HMV. Pressure support was increased in 2 patients and reduced in 3 patients mainly in relation to increases in EPAP which was increased in 4 patients.

#### *Data from full polysomnography*

There was no significant difference observed in the sleep quality, determined from the full overnight polysomnography data, between the initiation of HMV and 3 months post therapy initiation. (Table 28). Two patients slept for less than 4 hours at both the initiation of HMV and 3 months post HMV therapy. Median sleep efficiency was 77.3% on the first night and this decreased further at 3 months to 68.4% in line with previous studies.(176) The median arousal index at initiation was high 26.7 (11-38) per hour with 4 patients experiencing over 30 arousals per hour. The arousal index did not

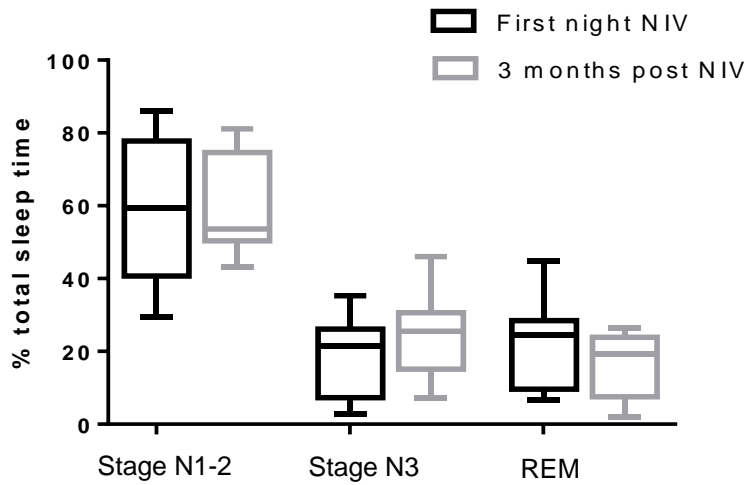
change with time on HMV and was 23.4 (14-30) per hour following 3 months of treatment, although the number of patients that experienced greater than 30 arousals per hour was only 2. There was no significant difference observed between percentage of time spent in stage 1 and 2, stage 3 or REM sleep stages at initiation and 3 months post HMV therapy initiation. (Figure 54).

**Table 28: Sleep quality measures recorded from full overnight polysomnography at initiation and 3 months post NIV therapy**

First night NIV						3 months post NIV therapy				
No.	TST (min)	SL (min)	SE (%)	WASO (min)	AI <sub>psg</sub> n/hr	TST (min)	SL (min)	SE (%)	WASO (min)	AI <sub>psg</sub> n/hr
1	376	13	74.7	115	13.4	351	45	68.4	118	43.8
2	237	28	44.6	266	38.5	200	42	35.5	321	31.2
3	304	32	57.1	196	27.6	n/a				
4	129	146	22.5	297	6.1	220	76	42.6	220	18.0
5	477	14	88.3	50	12.2	403	22	80.8	74	7.5
6	486	15	93.6	18	34.3	387	11	80.7	82	23.4
7	381	32	81.5	55	25.7	301	52	69.5	81	15.7
8	457	36	88.1	26	3.0	302	49	64.0	121	12.1
9	274	68	49.9	207	44.7	383	144	60.6	105	28.1
10	421	36	79.9	71	37.2	494	27	91.5	20	27.8
Median	379	32	77.3	93	26.7	351	45	68.4	105	23.4
IQR	(265-462)	(15-44)	(49-88)	(44-222)	(11-38)	(261-395)	(25-64)	(52-81)	(78-171)	(14-30)

*Abbreviations:* TST = total sleep time, SL= sleep latency, SE= sleep efficiency, WASO= wake time after the first onset of sleep, AI<sub>psg</sub>= arousal index determined from full polysomnography data, min-minutes, n/hr-number of events per hour.

**Figure 52: Box Plots showing the changes in sleep stage between first night and 3 months post HMV therapy initiation**



*Data are expressed as median and the interquartile range for the percentage of nocturnal sleep time spent in light stage sleep (stage N1-2), deep sleep (stage N3) and rapid eye movement (REM) sleep.*

Following 3 months of HMV therapy a reduction of 0.5 (1.7-0.1)kPa in overnight TcCO<sub>2</sub> was observed. Oxygen saturations overnight improved by 2.6 (-0.2-6.9) % following 3 months of HMV therapy. Two COPD patients received oxygen therapy that remained constant over the 3 month period. Post completion of the trial at 3 months, one patient had oxygen removed and one patient received a reduction in oxygen prescription (2L/min to 1L/min overnight) due to improvements in nocturnal hypoxia. COPD patients (n = 4) had the greater improvement in mean nocturnal TcCO<sub>2</sub> of 1.2 (2.2-0.6) kPa compared to 0.6 (1.2-0.2) kPa in the NMD group (n = 4). COPD patients also had a greater improvement in mean nocturnal oxygenation of 4.9 (-0.8- 21.3) % compared to 2.8 (0.5-3.8) % in the NMD patients. ORRF patients were not included as only one patient completed the study.

No significant changes were observed in the apnoea hypopnea index (AHI) and 4% oxygen desaturation index (ODI) between initiation and 3 months of HMV therapy (p=0.79 and p=0.08, respectively). There was an increase in AHI 1.7(-4.2-2.4) events per hour following 3 months of HMV therapy and a reduction in 4% ODI of 1.8 (28-2.7) events per hour. COPD patients demonstrated the greatest reduction in 4% ODI of 18.2 (57.2- 3.8) events per hour and a small increase in AHI 2.2 (-4.2- 9.7) events per hour with 3 months of HMV treatment. NMD patients experienced a small reduction in

both AHI and 4% ODI with time on HMV (1.0 (6.2-1.6) events per hour and 2.4 (15.4-7.4) events per hour, respectively).

**Table 29: Nocturnal Respiratory Parameters**

First night NIV					3 months post NIV therapy				
No.	TcCO <sub>2</sub> mean, max (kPa)	SpO <sub>2</sub> mean, min (%)	AHI n/hr	4% ODI n/hr	TcCO <sub>2</sub> mean, max (kPa)	SpO <sub>2</sub> mean, min (%)	AHI n/hr	4% ODI n/hr	
1	8.8, 9.5	67.4, 28.0	0.6	78.3	6.8, 7.6	92.6, 78.0	12.6	14.3	
2	7.5, 8.3	89.4, 71.0	9.1	29.6	8.4, 9.6	88.4, 61.0	10.8	34.4	
3	5.5, 6.9	99.8, 93.0	9.7	0.6	n/a				
4	7.0, 7.7	95.4, 76.0	2.3	14.9	6.5, 7.1	95.2, 79.0	4.4	13.1	
5	8.4, 10.3	81.8, 46.0	7.7	48.5	6.1, 6.5	91.5, 78.0	1.5	11.6	
6	6.9, 7.1	92.3, 89.0	2.7	0.5	6.5, 6.8	92.3, 88.0	5.4	1.1	
7	8.6, 9.5	95.6, 79.0	2.2	21.1	7.3, 8.0	98.6, 90.0	0.0	2.1	
8	6.6, 6.9	91.0, 80.0	0.0	2.9	5.6, 6.1	95.0, 72.0	0.2	12.7	
9	7.5, 9.5	96.3, 86.0	7.9	3.2	7.3, 8.5	98.9, 85.0	10.0	3.2	
10	5.4, 6.5	99.1, 81.0	27.2	6.5	5.7, 6.5	98.9, 84.0	19.7	1.8	
M	7.3 8.0	93.8 79.5	5.2	18.0	6.5 7.1	95.0 79.0	5.4	11.6	
IQR (6-8)	(7-10)	(88-97) (65-87)	(2-9)	(3-34)	(6-7) (7-8)	(92-99) (75-87)	(1-11)	(2-14)	

*Abbreviations:* M= Median, IQR =intra quartile range, TcCO<sub>2</sub>= transcutaneous carbon dioxide level, SpO<sub>2</sub> =oxygen saturations, AHI= apnoea, hypopnea index, 4% ODI= 4% oxygen desaturation index, n/a= not applicable (patient failed to attend for 3 month follow up), n/hr-number of events per hour, max-maximum, min-minimum.

Overall, PVA was more frequent during wake with approximately twice as many events occurring than during sleep although with marked individual variability and so a significant difference was not achieved. There was no change in PVA occurring during wake between initiation of HMV and 3 months post HMV therapy initiation (18 (-189-153) events per hour; p=0.9). Similarly, there was no change in PVA during sleep observed (-12 (-135-87) events per hour; p=0.9). (Table 30).

**Table 30 : Integrated 2 minute respiratory polygraphy and 10 minute polysomnography data**

First night NIV							3 months post NIV therapy					
No.	Anls (hr:min)	% PVA breaths	PVA <sub>wake</sub> (events/hr)	PVA <sub>sleep</sub> (events/hr)	AI <sub>total</sub> (n/hr)	AI <sub>PVA</sub> (n/hr)	Anls (hr:min)	% PVA breaths	PVA <sub>wake</sub> (events/hr)	PVA <sub>sleep</sub> (events/hr)	AI <sub>total</sub> (n/hr)	AI <sub>PVA</sub> (n/hr)
1	1:10	45	576	546	14	5	1:12	18	198	162	43	18
2	1:04	22	138	306	31	26	1:10	20	162	294	31	14
3	1:16	16	192	90	32	14	n/a					
4	0:42	52	492	552	14	14	0:30	61	846	912	13	9
5	1:12	17	288	120	9	8	1:00	4	162	36	7	3
6	1:12	29	168	216	37	17	1:12	32	234	258	18	8
7	1:14	21	432	108	26	20	1:08	24	414	90	21	9
8	1:12	21	300	204	2	1	1:12	11	318	18	3	1
9	1:08	22	306	90	47	35	1:12	38	546	216	19	10
10	1:12	11	504	54	35	14	1:12	14	252	102	31	17
<b>M</b>	1:12	22	303	162	29	14	1:12	20	252	162	19	9
<b>IQR</b>	(1:07-1:13)	(17-33)	(186-495)	(90-366)	(13-35)	(7-25)	(1:04-1:12)	(13-35)	(180-480)	(63-276)	(10-31)	(6-16)

Total data are represented as median (M) and interquartile range (IQR). *Abbreviations:* Anls = total 2 minute detailed analysis time per patient, %PVA breaths=percentage of breaths affected by all patient ventilator asynchrony, PVA<sub>wake</sub>=number of total patient ventilator asynchrony observed per hour during wake, PVA<sub>sleep</sub>=number of total patient ventilator asynchrony observed per hour during sleep, AI<sub>total</sub> = analysis total arousal index, AI<sub>PVA</sub>= arousal index during detailed analysis within 3 seconds of a patient ventilator asynchronous event, hr-hour, min-minutes, n/hr-number per hour.

COPD patients demonstrated less PVA during wake than NMD patients at both initiation of HMV and 3 months post HMV initiation (initiation: COPD 228 (146-504) events per hour and NMD 369 (302-486) events per hour, 3 months post HMV therapy: COPD 180 (162-225) and NMD 366 (269-513)). However, NMD patient had less frequent PVA during sleep than COPD patients both at initiation of HMV and following 3 months of HMV therapy (initiation: COPD 261 (144-486) and NMD 99 (63-180), 3 months post HMV therapy: COPD 210 (68-285) and NMD 96 (36-188)). Arousals preceded by PVA were similar in both patient groups.

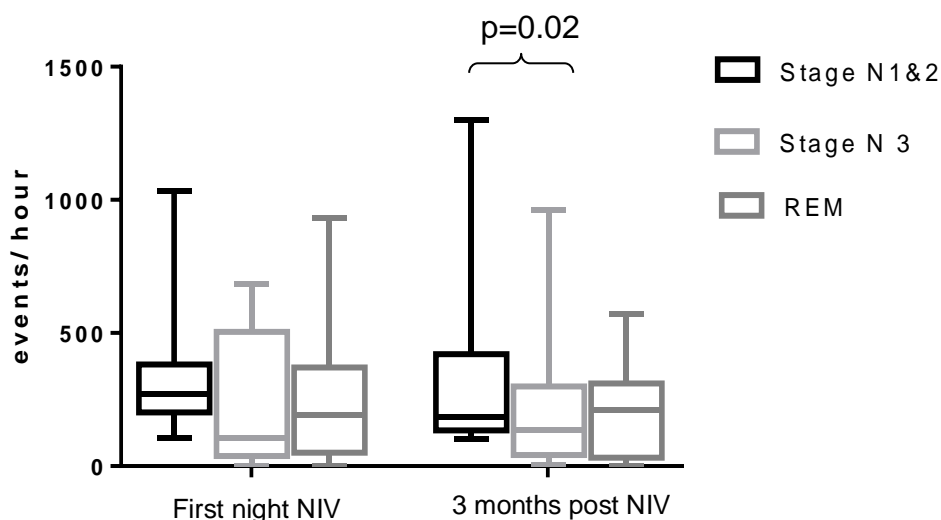
A reduction in the frequency of PVA occurring in both wake and sleep was observed in the COPD patients (51 (-315- 56) events per hour and 48 (-309-29) events per hour, respectively) following 3 months of HMV therapy. No change was observed in the frequency of PVA occurring in wake in NMD patients following 3 months of HMV therapy. A small increase was observed in PVA occurring during sleep 15 (-144-107) in patients with NMD.

### 5.4.1 Patient ventilator asynchrony and sleep stages

The majority of PVA occurred during stages 1 and 2 sleep both during the first night of NIV and 3 months post NIV therapy with a  $PVA_{\text{sleep}}$  index of 269 (202-382) events per hour and 186 (134-421) events per hour, respectively. PVA persisted during REM sleep in this study and we observed no significant attenuation in NRD with a  $PVA_{\text{sleep}}$  index of 192 (51-370) events per hour at initiation and 209 (32-310) events per hour post 3 months of HMV therapy. The lowest PVA occurred during stage 3 sleep with a  $PVA_{\text{sleep}}$  index of 105 (38-504) events per hour at the initiation of HMV and 135 (42-299) events per hour 3 months post HMV initiation. Although there was no significant difference observed in the number of asynchronous events occurring in the different sleep stages at initiation of HMV, by 3 months of therapy the  $PVA_{\text{sleep}}$  index was higher in stage 1 and 2 sleep compared to stage 3 at 3 months post therapy ( $p=0.02$ ). (Figure 55).

Despite this, there was no overall statistically significant difference observed in PVA frequency at any sleep stage between the initiation of NIV and 3 months post therapy (stage 1 and 2  $p=1.0$ ; stage 3  $p=0.6$ ; REM  $p=1.0$ ).

**Figure 53: Box Plots showing the changes in total PVA with sleep stages between first night NIV and 3 months post NIV therapy**

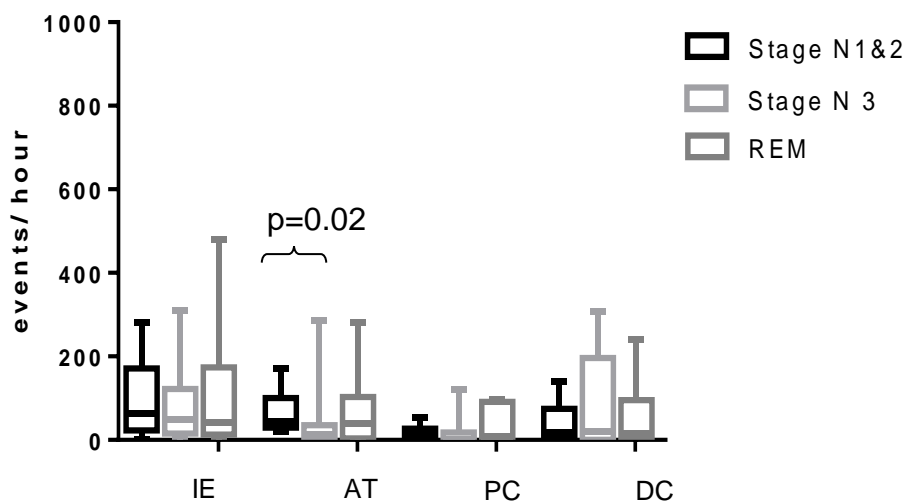


There was no difference observed in the frequency of ineffective efforts, premature expiratory cycling or delayed expiratory cycling across the sleep stages at the initiation of HMV (ineffective efforts  $p=0.97$ , premature cycling  $p=0.52$ , delayed cycling  $p=0.75$ ).

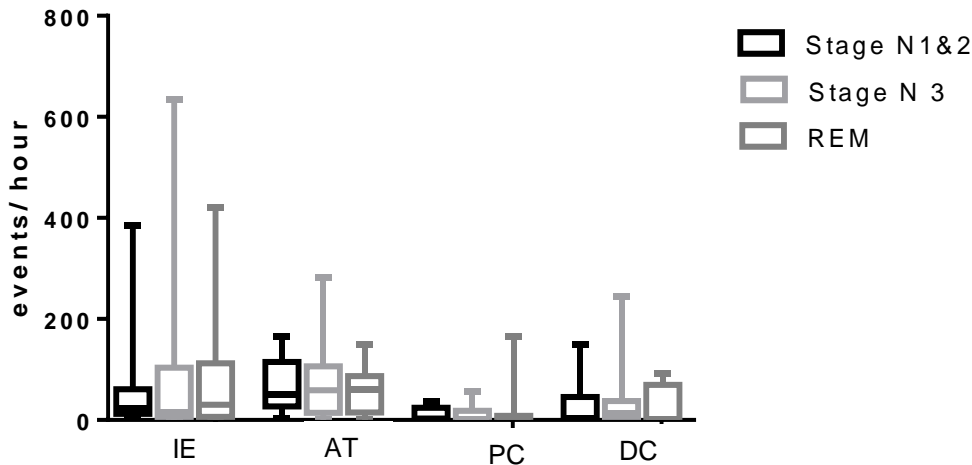
Auto-triggering occurred more frequently sleep stages 1 and 2 than in deep stages of sleep at initiation of HMV ( $p=0.02$ ). (Figure 56)

There were no significant differences in the frequency of ineffective efforts, auto-triggering, premature expiratory cycling and delayed expiratory cycling between the different sleep stages at 3 months post NIV therapy (ineffective efforts  $p=0.69$ ; auto-triggering  $p=0.40$ ; premature expiratory cycling  $p=0.44$ ; delayed expiratory cycling  $p=0.91$ ). (Figure 57).

**Figure 54: Box Plots demonstrating the changes in the most frequent triggering (ineffective efforts (IE) and auto-triggering (AT)) and cycling (premature cycling (PC) and delayed expiratory cycling, (DC)) asynchronous events at different sleep stages at initiation of HMV**



**Figure 55: Box Plots demonstrating the changes in the most frequent triggering (ineffective efforts (IE) and auto-triggering (AT)) and cycling (premature cycling (PC) and delayed expiratory cycling, (DC)) asynchronous events at different sleep stages post 3 month initiation of HMV**



No correlation was observed between  $PVA_{\text{sleep}}$  and the percentage of sleep time spent in stage 3 or REM sleep at initiation of HMV ( $r_s=0.46$ ,  $p=0.19$  and  $r_s=0.47$ ,  $p=0.18$ ; respectively). Neither was a correlation observed between  $PVA_{\text{sleep}}$  and stage 3 sleep or REM sleep at 3 months post HMV therapy ( $r_s=0.15$ ,  $p=0.71$  and  $r_s=-0.43$ ,  $p=0.25$ ).

#### 5.4.2 Patient ventilator asynchrony and sleep disruption

PVA preceded 48% of the total arousals at initiation of HMV and 47% post 3 months of HMV. There was no significant reduction in the number of arousals preceded by PVA between baseline HMV set up and 3 months post therapy (14 (7-21) events per hour vs. 9 (6-16) events per hour;  $p=0.98$ ). Although the prevalence of PVA during sleep is high, only 8 (2-24)% of  $PVA_{\text{sleep}}$  at initiation of HMV and 6 (4-11)% of  $PVA_{\text{sleep}}$  at 3 months preceded an arousal. No difference in the small proportion of asynchronous events resulting in sleep disruption was observed following 3 months of HMV therapy ( $p=0.6$ ). Similarly, no significant reduction in non-PVA induced arousals was observed with 3 months of HMV (8 (1-14) events per hour vs 10 (4-16) events per hour;  $p=0.5$ ). (Table 30).

Ineffective efforts were most frequently associated with arousals 3 (1-4) per hour on the first night of HMV set up and 3 (1-3) per hour 3 months post HMV therapy. The next most frequent PVA

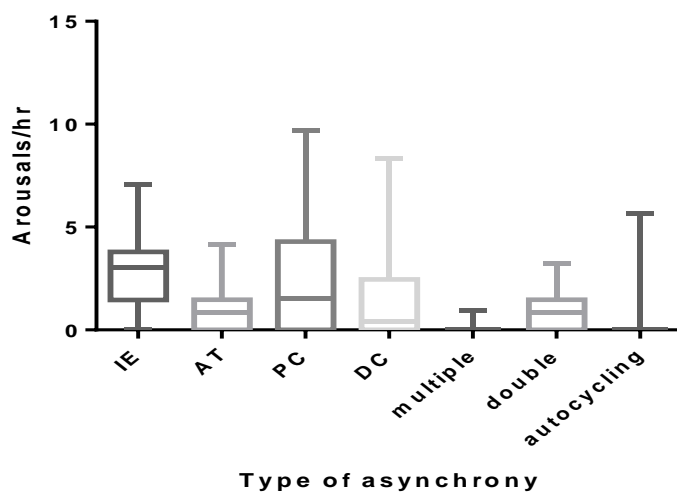
associated with arousals were premature cycling events which led to 2 (1-4) arousals per hour on the first night of HMV and 1 (0-3) at 3 months post therapy. All the other asynchrony preceded less than 1 arousal per hour on both the first night of NIV and 3 months post NIV therapy. (Figures 58 & 59).

Ineffective efforts were significantly more likely to precede an arousal at both initiation and 3 months than a multiple asynchronous event ( $p < 0.01$  at initiation and  $p < 0.001$  at 3 months).

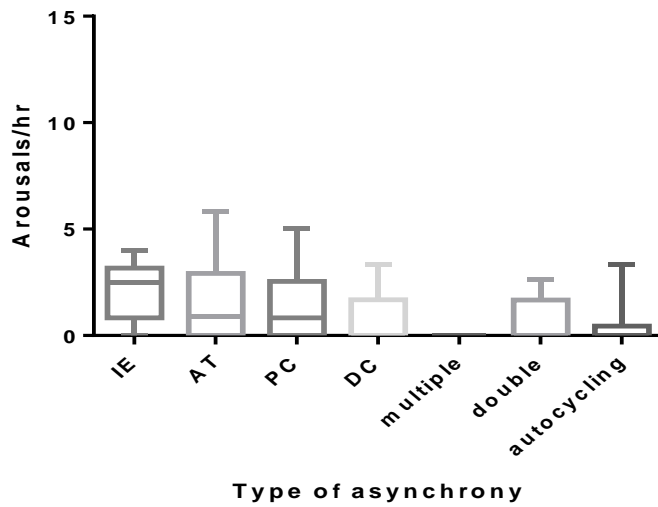
The majority of arousals preceded by PVA occurred in sleep stages 1 and 2, 76% at initiation and 78% at 3 months post HMV therapy. In contrast, few arousals occurred in slow wave sleep (16% at initiation of HMV, 21% at 3 months) and REM sleep (8% at initiation of HMV, 1% at 3 months).

Only a small proportion of the asynchronous events that occurred during sleep led to arousals and very few of these arousals resulted in an awakening, total awakenings preceded by PVA were 1.0 (0.8-3.3) event per hour at initiation and 2.0 (1.0-2.0) events per hour at 3 month assessment.

**Figure 56: Box plots indicating the number of arousals per hour related to the individual types of asynchrony during the first night of NIV**



**Figure 57: Box plots indicating the number of arousals per hour related to the individual types of asynchrony post 3 months of NIV therapy**

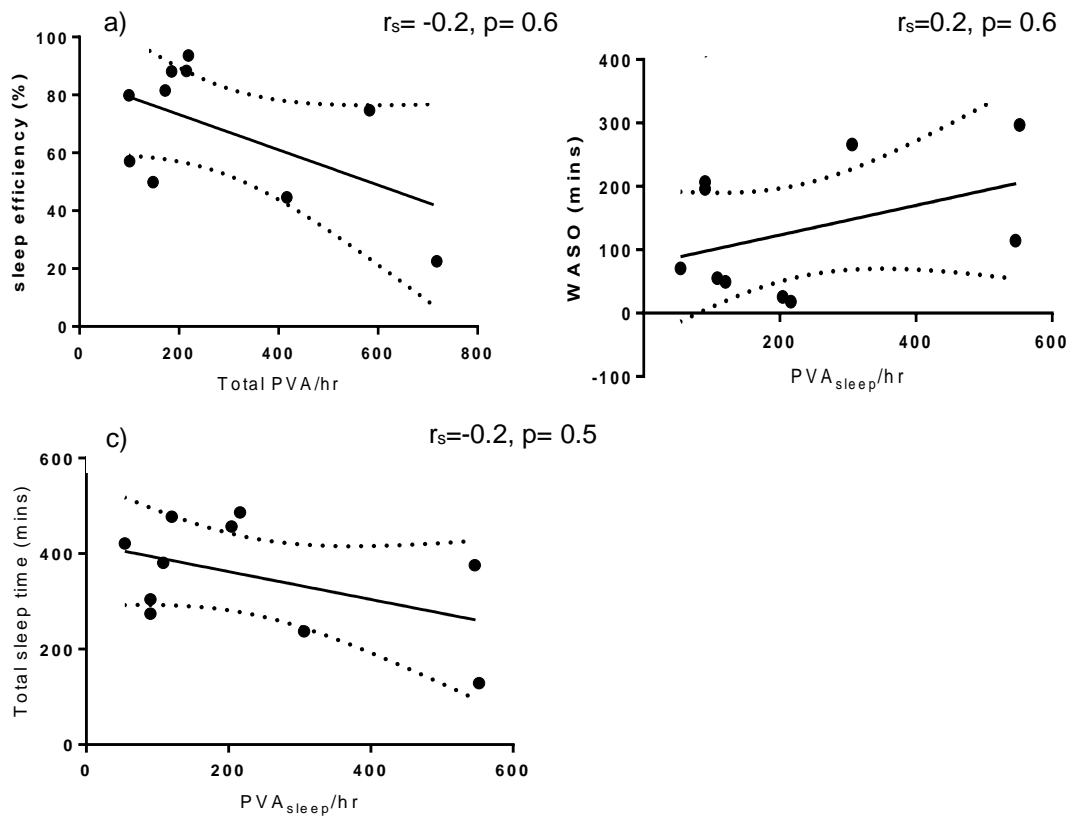


PVA<sub>sleep</sub> levels were not significantly correlated with the arousal index overnight at initiation of HMV or 3 months post HMV therapy (initiation:  $r_s = -0.5$ ,  $p = 0.2$ , 3months:  $r_s = 0.3$ ,  $p = 0.4$ ).

#### 5.4.3 Patient ventilator asynchrony and sleep quality

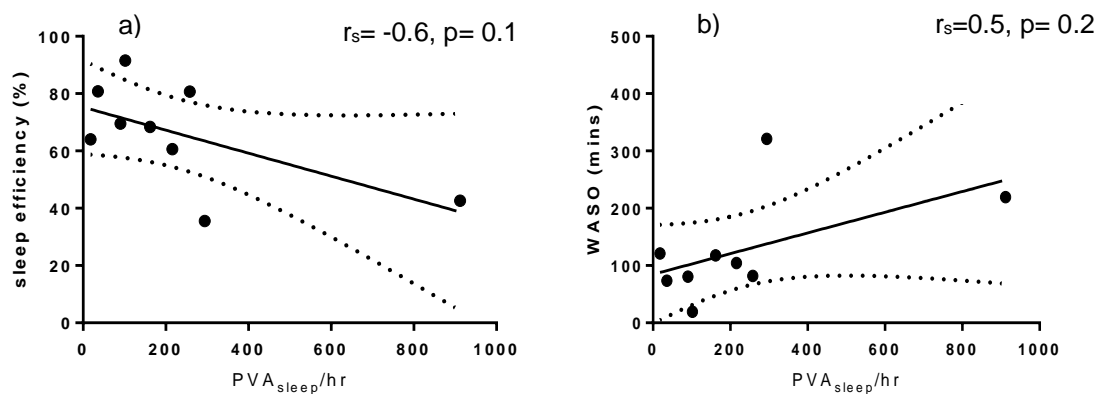
No significant relationship was observed between the PVA levels occurring during sleep and overall sleep efficiency, WASO or total sleep time at either initiation of HMV or 3 months post therapy. (Figures 60 & 61). No significant relationship was observed between the amount of PVA during wake and sleep latency at initiation of HMV. However, a significant relationship was observed between the frequency of PVA during wake and the sleep latency at 3 months. (Figure 62).

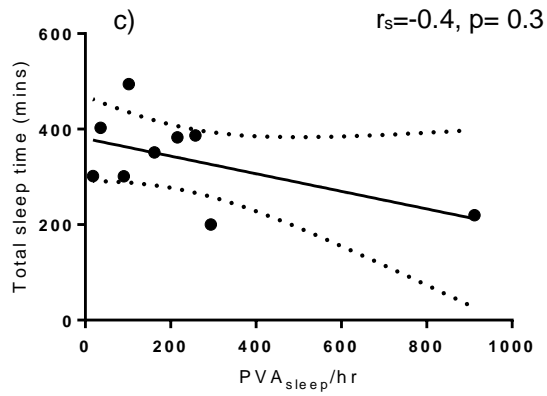
**Figure 58: Spearman correlation between PVA<sub>sleep</sub> and a) sleep efficiency, b) WASO and c) total sleep time during the first night of HMV**



*Abbreviations:* Total PVA- patient ventilator asynchrony (whole night study), PVA<sub>sleep</sub>-patient ventilator asynchrony occurring during sleep periods only, WASO- wake after sleep onset.

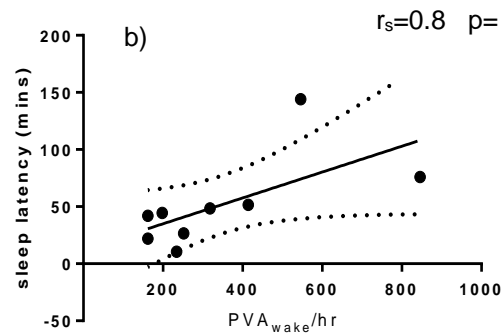
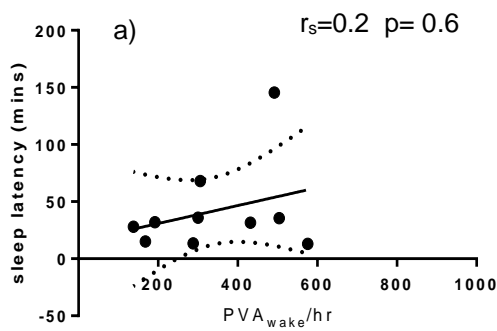
**Figure 59: Spearman correlation between PVA<sub>sleep</sub> and a) sleep efficiency, b) WASO and c) total sleep time 3 months post HMV therapy**





*Abbreviations:* Total PVA- patient ventilator asynchrony (whole night study), PVA<sub>sleep</sub>-patient ventilator asynchrony occurring during sleep periods only, WASO- wake after sleep onset.

**Figure 60: Spearman correlation between PVA<sub>wake</sub> and sleep latency at a) first night NIV and b) 3 months post NIV therapy**



*Abbreviations:* PVA<sub>wake</sub>-patient ventilator asynchrony occurring during wake periods only.

**Table 31: Clinical impact of PVA on arousals and awakening during HMV set up and at 3 months**

	PVA <sub>sleep</sub> (per/hr)	PVA arousal index (per/hr)	PVA arousal index/PVA <sub>sleep</sub> (%)	Awakenings (per/hr)
At HMV Initiation	162 (90-366)	14 (7-25)	8 (2-24)	1 (1-3)
3 months Post Initiation	162 (63-276)	9 (6-16)	6 (4-11)	2 (1-2)

*Abbreviations:* PVA<sub>sleep</sub>-patient ventilator asynchrony occurring during sleep periods only, PVA arousal- patient ventilator asynchronous events preceding an arousal.

Although the total PVA during sleep was high, the PVA arousal index was significantly lower at initiation of HMV (162 (90-366) per hour vs 14 (7-25) per hour;  $p < 0.0001$ ). A similar observation was made a 3 months post HMV therapy (162 (63-276) vs 9 (6-16);  $p < 0.0001$ ). The PVA arousal index when normalised for the total PVA during sleep was only 8 (2-24) % at initiation which did not change significantly after 3 months of HMV 6(4-11) %; ( $p = 0.60$ ). Furthermore, there was a low conversion rate between PVA induced arousals and awakenings at initiation of HMV and 3 months post HMV therapy. No relationship was observed between PVA arousal index and measures of sleep quality such as sleep efficiency ( $r = -0.35$ ;  $p = 0.32$ ), WASO ( $r = 0.37$ ;  $p = 0.29$ ) and total sleep time ( $r = -0.39$ ;  $p = 0.27$ ) at initiation of HMV. Similarly, no correlation was observed between PVA arousal index and measures of sleep quality such as sleep efficiency ( $r = -0.10$ ;  $p = 0.80$ ), WASO ( $r = 0.04$ ;  $p = 0.92$ ) and total sleep time ( $r = -0.03$ ;  $p = 0.96$ ) at 3 months post HMV therapy.

## **5.5 Discussion**

### **5.5.1 Main findings**

All patients in this small detailed physiological study, using a novel method to assess patient ventilator asynchrony overnight, were shown to have a high frequency of asynchronous events. Patient ventilator asynchrony was observed in over a fifth of breaths analysed during initial set up of HMV therapy and this did not change after 3 months post HMV therapy. Sleep quality in patients receiving HMV was reduced and this did not significantly improve following 3 months of HMV therapy in terms of changes in sleep efficiency, total sleep time, wake after sleep onset and sleep latency. Interestingly, there was no relationship between total PVA during sleep and measures of sleep quality, which is not unexpected as there was no relationship between total PVA during sleep and the PVA induced arousal index at either initiation or post 3 months of HMV therapy. Furthermore, there was no relationship observed between PVA during sleep and the time spent overnight in slow wave (stage 3) sleep and REM sleep.

### **5.5.2 Critique of the Method**

All patients in this study, were ventilated in pressure support mode using the NIPPY3+ home mechanical ventilator (B&D Electromedical, Stratford-upon-Avon, UK). As mentioned previously, the results from this study may be related to the operating characteristics of this ventilator and the frequency of PVA may not be applicable to other brands of home ventilator. However, we considered it more important in this small detailed physiological study to accommodate for confounders, such as the triggering and pressure delivery system of the ventilator, by using only one brand of home ventilator.

All patients were naïve to HMV and so the first night of HMV therapy is likely to be highly disruptive with patient being unfamiliar with the interface and pressure support along with increased anxiety levels impacting on sleep. Due to the nature of initiation of HMV at the Lane Fox respiratory unit in a busy NHS service, patients have a short length of stay, but it may have been preferable to investigate the changes in sleep disruption relating to HMV following a short acclimatisation period, such as one week. However, this was the first such study to investigate the relationship between patient ventilator asynchrony and arousal in patients with chronic respiratory failure and therefore it was most important

to establish the technique to integrate electroencephalography with electromyography to quantitatively assess PVA and arousal index.

As the equipment burden on the patient was cumbersome, and at the request of the patient, we performed polysomnography without the pre-tibial electromyogram. We acknowledge that although the relationship between periodic limb movements (PLMs) and patient ventilator asynchrony has not previously been investigated, in the current study it is not possible to confirm that all the arousals observed following an asynchronous event were not related to other stimuli, such as PLMs.

We appreciate that discomfort from the polysomnography monitoring in the hospital environment may have impacted on the sleep quality. This may, in part, explain the lack of improvement in sleep quality over the 3 months of HMV therapy. Indeed, sleep quality measured in patients in the comfort of their home environment where this therapy is delivered may not be reflective of the overnight study in the hospital. However, we asked the patients in the morning after each study if they slept adequately and the overall response from the patients was that they had achieved adequate sleep quality similar to the home environment. Interestingly, a previous study that compared sleep quality in patients in the hospital and at home reported a deterioration of sleep quality in the home environment with increased air leaks occurring at the interface.(176)

One caveat to the changes observed in TcCO<sub>2</sub> is that the transcutaneous measurement of carbon dioxide may fluctuate from day to day related to skin preparation and limitations of the technology. Limited data are available on the natural variability of transcutaneous monitoring between consecutive overnight studies. To overcome drift each overnight study was anchored to the patient's arterial blood gas prior to sleep. The CO<sub>2</sub> sensor (stow-severinghaus electrode) was applied to patient by the same operator for all studies. Furthermore, this method has been validated as a reliable monitoring tool in patients receiving HMV.(151)

Arousals are to some extent arbitrarily defined as lasting more than 3 seconds and so the impact of PVA on microarousals (periods of PSG disturbance lasting less than 3 seconds) may be underestimated in this study and yet have cardiovascular consequences related to autonomic responses such as raised heart rate and blood pressure.(177) In addition, arousals leading to sleep stage shift were not examined in this study which may also have impacted on sleep quality.

### *Relationship between patient-ventilator asynchrony and arousal*

The majority of PVA during sleep did not precede an arousal with only 8 (2-16) % of PVA at initiation of HMV and 8 (4-10) % of PVA at 3 months post HMV therapy occurring before an arousal according to our definition. Nevertheless, because of the high frequency of PVA, this resulted in PVA preceding 48% of all arousals observed at initiation and 47% of all arousals at 3 months post HMV therapy. Interestingly, there was no improvement in the frequency of total PVA during sleep or wakefulness following 3 months of HMV therapy and there was no change in the number of PVA preceding arousals over this period. However, the proportion of PVA during sleep that resulted in an arousal, when normalised for the total PVA during sleep, fell from 8.6% to 5.6% and these data supports that although the total PVA during sleep may not fall, as in this study, the arousal threshold changes such that the PVA induced arousal index decreased. This would support the suggestion that the patient adapts to the HMV albeit the frequency of asynchronous events remains high.

We did not find a relationship between PVA occurring during sleep and measures of sleep quality including sleep efficiency, total sleep time and WASO at either initiation of HMV or post 3 months of HMV therapy. To our knowledge, no such association has been demonstrated in any previous studies. Work by Guo *et al.* comparing obesity hypoventilation patients with and without PVA overnight did not demonstrate any difference in total sleep time or sleep efficiency. Neither could we demonstrate a correlation with PVA during sleep and the arousal index. This conflicts with data from Bosma *et al.* and Crescimanno *et al.* who found a positive correlation between the total arousal index per hour and PVA per hour.(91, 176) Patients in the study by Bosma *et al.*, were weaning from invasive mechanical ventilation and examined on an ICU ventilator (Evita 4, Drager, Germany).(91) Patient ventilator interaction and threshold for arousals is likely to be very different in recovery from an acute illness compared to a stable elective setting. In addition, neither of these earlier studies examined electromyography as a marker of patient inspiratory effort. Both Luo *et al.* and we have demonstrated that patient neural respiratory drive may occur without thorax excursion and so the proportion of PVA in both of these studies may have been underestimated.(109) (See Chapter 4-4.4.3 clinical consequences of sEMGpara).

The relationship between PVA and arousals remains complex. Data from this study suggest that the majority of PVA (92%) do not precede arousals. However, due to the high frequency of PVA

approximately half of all arousals were preceded by PVA with a very variable response between individuals. Ineffective efforts were the most frequent PVA preceding an arousal followed by premature cycling and therefore may be the most appropriate PVA to target to improve sleep quality. Although very few PVA led to awakenings and no correlation of PVA arousal index with changes in sleep efficiency, wake after sleep onset and the total sleep time were demonstrated suggesting that overall little measurable related sleep disruption occurred. However, the clinical impact of arousals that do not lead to sleep fragmentation on daytime symptoms is unclear.

In view of the high frequency of PVA in this study, it is unclear if some of the associations with arousals in this study may represent an 'epi-phenomenon' and not a direct effect of the PVA. We are also unaware if a single PVA is sufficient to result in an arousal or if many PVA may need to occur in quick succession to lead to sleep disruption. Some studies examining PVA have chosen to only consider 3 consecutive breaths affected by PVA and others have stipulated that these must occur within a time frame of 10 seconds.(70, 176) Although there remains no clear evidence, that one definition leads to more sleep disruption than another. It has also been suggested that cortical arousals may attenuate with recurrent arousing stimuli raising the arousal threshold for example in patients with OSA (177, 178). It is likely that different patients may have different arousal thresholds and this may be further influenced by the levels of hypercapnia, sleep stage and underlying disease pathology. In support of a sleep stage effect on arousals, both our work and Guo *et al.* have demonstrated that very few arousals occurred in slow wave and REM sleep.(70)

#### *Patient ventilator asynchrony in the awake state*

There was no relationship between PVA that occurred during the awake state and markers of sleep quality at initiation of HMV. However, after 3 months of HMV therapy, a correlation was observed between the PVA during wakefulness and sleep latency, which suggests that the presence of PVA in the awake state may prevent the patient relaxing sufficiently to enter into sleep. This effect may be more apparent post adaption to HMV as other external factors, such as anxiety and interface intolerance, are likely to impact on sleep latency on the first night of HMV therapy in naïve patients.

PVA occurred more frequently during wake than sleep at both initiation and post 3 months of HMV in our patients, although this was not statistically different. To our knowledge this is the first study to describe the high prevalence of PVA during wake overnight which was an unexpected finding. These

high levels may relate to alterations in pulmonary mechanics when transitioning from sleep to wake with respiratory pathology or reflect patient anxiety when waking on HMV overnight.

#### *Nocturnal gas exchange and respiratory events*

There was no change observed in the 4% ODI or AHI following 3 months of HMV therapy. As little is known about the night-to-night variation of these measurements in patients treated with HMV, the small individual fluctuations observed in this study may simply reflect this. In untreated patients with upper airway pathology leading to sleep disordered breathing, 15% were demonstrated to have significant variability in AHI between two consecutive polysomnography assessments.(179) A study comparing gas exchange between a full face mask and a nasal mask on two consecutive nights in patients with hypercapnic respiratory failure did not find significant differences in mean oxygen saturations and transcutaneous carbon dioxide level.(180) COPD patients demonstrated a larger reduction in 4% ODI than the NMD patients which is likely to relate to the high prevalence of concurrent obesity in COPD patients in this study. A small increase in the AHI was observed in this group, which may represent underlying levels of alveolar hypoventilation that have been unmasked following treatment of the upper airway obstruction. However, the accurate assessment and scoring of AHI is challenging in patients receiving HMV (34) and to accommodate for this all PSG studies were scored by the same experienced sleep technician (ID) in accordance with the somnoNIV definitions.

#### *Effect of HMV on sleep quality*

Few studies have objectively investigated the effects of HMV on sleep quality. Most studies have been based on patient reported subjective improvements to sleep quality.(98, 181, 182) Other studies have suggested that mechanical ventilation itself may result in severe sleep disruption related to ventilator induced central apnoeas and PVA.(70, 75, 174, 176) One study that assessed sleep quality using PSG in ALS patients could not demonstrate improvements in sleep quality following HMV.(183)

In our study, sleep efficiency was reduced at initiation of HMV and at 3 months, but with marked variation between individuals. This was similar to the sleep efficiency reported by Guo *et al.* in obesity

hypoventilation patients established on HMV.(70) Sleep efficiency, total sleep time, sleep latency and wake after sleep onset did not improve in our patients following 3 months of HMV therapy. In fact, a reduction in sleep efficiency was observed in 6 of the 9 patients studied. The change in sleep efficiency in these patients was driven by a reduction in the total sleep time related predominantly to an increase in wake after sleep onset. The reduction in sleep efficiency over time may relate to baseline sleep deprivation levels in some patients due to sleep disordered breathing prior to the initiation of HMV. In support of this, 3 patients had a sleep latency of less than 15 minutes at initiation of HMV compared to 1 patient at 3 months post HMV therapy. Alternatively, the deterioration in sleep efficiency may emphasise the poor sleep quality of patients on HMV which contradicts patient perception.

#### *Relationship between patient-ventilator asynchrony and sleep stage*

In accordance with previous studies, a higher incidence of PVA was observed during stage 1 and 2 sleep compared to stage 3 slow wave sleep, which reached statistical significance post 3 months of HMV therapy.(70, 176) However, in contrast to other studies we also found a higher prevalence of PVA in REM sleep compared to stage 3 sleep, although this did not reach statistical significance. There was no relationship observed between sleep stage and the four commonest types of asynchrony, with the exception of auto-triggering that was more commonly observed in stage 1 and 2 light sleep at initiation of HMV. This is the first study to evaluate the contribution of each asynchrony to sleep disruption. Ineffective efforts led to the most arousals both at initiation of HMV and following 3 months of HMV therapy followed by premature expiratory cycling. Ineffective efforts were more likely to precede an arousal than multiple triggering which is likely to relate to the higher frequency of ineffective efforts observed overall.

There were no changes observed in time spent overnight in different sleep stages between the first night of HMV therapy and 3 months post HMV therapy. As reported earlier, PVA was more frequently observed in light sleep than slow wave sleep. Similar results were observed by Guo *et al*, in stable obesity hypoventilation patients established on HMV (70), although we observed greater PVA in REM sleep than in slow wave sleep. The latter may be a manifestation of the erratic changes in breathing patterns adopted by patients in REM sleep impacting on patient ventilator synchronisation.

COPD patients experienced more PVA during sleep than NMD patients both at initiation of HMV and 3 months post HMV therapy. Whereas, NMD patients experienced more PVA during wake than COPD patients. COPD patients also demonstrated some improvement in PVA levels both during wake and sleep over time on HMV which was not observed in NMD patients.

In agreement with work by Crescimanno *et al.* in neuromuscular patients, we found more auto-triggering in light stages of sleep at the initiation of HMV. PVA including auto-triggering have been correlated with increasing leaks on mechanical ventilation.(80, 89) Crescimanno *et al.* hypothesised that increased amounts of auto-triggering may have resulted from higher levels of leak in non-REM sleep although a significant difference in unintentional leaks on NIV between sleep stages has not been established.(176, 184) Adaption to the interface at initiation of HMV including the patient learning methods to control unintentional leak overnight may explain the increased levels occurring in light sleep in our study. Interestingly, the proportion of auto-triggering occurring in stage 3 and REM increased following 3 months of HMV therapy which may suggest that patients adapt to leaks and sleep becomes less disrupted by auto-triggering following time spent on HMV.

In contrast to Crescimanno *et al* and Fanfulla *et al.*, we did not find a negative correlation between PVA and stage 3 or REM sleep.(75, 176) However, the prevalence of PVA was higher in our study, which may relate to the extended analysis throughout the whole night used to identify PVA in the current study. In addition, both of these earlier studies included only neuromuscular patients, whereas our study considered a heterogenous population, which limits comparison. (75, 176)

## **5.6 Conclusion and clinical relevance**

These current data have shown that patient-ventilator asynchrony during sleep was high, but that the asynchronous events resulting in an arousal were much lower. Indeed, if the arousals resulting from an asynchronous event are normalised for the total number of asynchronous events during sleep the proportion is low and falls even further following 3 months of HMV therapy supporting the concept of patient adaptation in terms of the arousal index. In addition, there was a low conversion rate demonstrated from between asynchrony induced arousal and awakening, which was itself a very infrequent event. There was no relationship between patient-ventilator asynchrony during sleep and sleep quality in terms of sleep efficiency, total sleep time, wake after sleep onset, arousal index or

time overnight spent in stage 3 or REM sleep. This observation was made in the context of severe amounts of PVA according to current literature definitions.

These data are reassuring to the clinician as although patient ventilator synchrony is common, arousals and waking overnight during HMV is much less common which supports HMV as a clinically useful tool that enhances nocturnal gas exchange, but not at the expense of sleep quality. This challenges the current clinical opinion that patient ventilator asynchrony frequently results in arousal and sleep disruption. Furthermore, these data suggest that detailed physiological or physician led set up set up for titrating HMV settings to achieve patient ventilator synchronisation during sleep may not lead to an improvement in sleep quality in the majority of patients and possibly should be targeted a specific patients who are unable to tolerate HMV. We have previously shown that there was no relationship between patient ventilator asynchrony and overnight gas exchange and that observation can be extended to a lack a relationship between patient ventilator asynchrony and sleep quality.(79) From these data, it may be more clinically relevant to focus on enhanced patient ventilator synchronisation and comfort whilst the patient is awake and using HMV in order to facilitate sleep onset and this approach would be supported by the relatively low sleep efficiency in patients receiving HMV. Finally, the clinical impact of arousals that do not lead to sleep fragmentation on daytime symptoms requires further investigation.

# **Chapter 6 The impact of inspiratory trigger delay on neural respiratory drive and the perception of comfort**

## **6.1 Introduction**

The inspiratory effort required to trigger the ventilator in the pressure support mode represents 10% to 30% of the total breathing effort of the patient.(8, 44) In addition, poor patient ventilator synchrony as a result of the triggering asynchrony adversely effects respiratory muscle unloading, increasing respiratory muscle oxygen consumption and negatively impacting on both the work of breathing and comfort of the patient.(8) Furthermore, triggering asynchrony is common and frequently underestimated being associated with poor outcome in invasively mechanically ventilated patients in the intensive care unit.(77, 78)

Trigger delays to ineffective efforts, represent extremes of a spectrum of triggering asynchrony and the distinction between meaningful trigger delays and ineffective efforts on clinical outcome is unclear. Ineffective efforts represent a triggering asynchrony with complete mismatch between the inspiratory effort of the patient and the pressure supported breath delivered by the ventilator and result in an increase in work of breathing, time spent with oxygen saturations below 90% and sleep disruption.(8, 75, 76) Trigger delay is the time between the onset of neural respiratory drive, demonstrated as the inspiratory muscle activity of the patient, and the delivery of a ventilator triggered pressure supported breath. This can be a frequent event in chronic obstructive pulmonary disease (COPD) patients with evidence of intrinsic positive end expiratory pressure (PEEPi) and neuromuscular patients who fail to generate a sufficient inspiratory effort to trigger the ventilator as a consequence of respiratory muscle weakness. Trigger delay has not been defined as a distinct type of triggering asynchrony, in part, because the optimal trigger response prior to an adverse impact on respiratory muscle unloading and clinical outcome, such as comfort, remains unclear. Furthermore, the trigger delay tolerated by patients with different disease pathologies causing chronic respiratory failure may vary. Thus, the clinical impact of trigger delay remains under recognised when assessing patient ventilator interaction.

Non-invasive ventilators vary in their performance characteristics with newer generation ventilators reporting enhanced triggering performance compared to older generation piston and turbine based ventilators.(185-187) Stell *et al.* compared the trigger response of thirteen non-invasive ventilators on a lung model designed to reflect obstructive airways disease.(7) Inspiratory trigger delays were predominantly in the range of 120ms to 300ms with small proportion of the ventilators tested with a triggering delay time of less than 100ms or more than 500ms.(7) Interestingly, all of the studies comparing trigger performance of the ventilators have been performed in lung model bench studies with the assumption that a faster trigger response is beneficial to the patient resulting in a lower the work of breathing and greater patient comfort.(7, 188, 189) To date there are no clinical studies, using subjective comfort and neural respiratory drive, in both healthy subject and COPD patients to determine the clinical effect of trigger delay.

### **6.1.1 Study aims**

We aimed to conduct a pilot study to investigate the relationship between trigger delay, self-reported comfort and respiratory muscle loading in both healthy subjects and COPD patients. We also investigated the components of the inspiratory trigger delay to characterise the onset and timing of delay.

## **6.2 Methods**

This study was approved by the local ethics committee and all patients provided written informed consent. Healthy subjects without underlying lung disease or medical co-morbidities and COPD patients established on HMV were enrolled in the study. All healthy subjects and COPD patients underwent spirometry testing, height and weight measurements and maximal inspiratory sniff pressure measurements. Baseline neural respiratory drive measurements (sEMG<sub>para</sub>) during stable tidal breathing were recorded over two minutes with participants seated in a chair at 45 degrees with their arms supported (as described in detail in material and methods chapter 2 -2.7.1). Neural respiratory drive was also measured during a maximal inspiratory sniff manoeuvres. To enable comparison between subjects neural respiratory drive, measurements were reported as a percentage of the maximum neural drive obtained from performing a maximal inspiratory manoeuvre (sEMG<sub>para</sub>%max).

### 6.2.1 Measuring inspiratory trigger delay

A custom-made NIPPY3+ ventilator (B&D Electromedical, Stratford-upon-Avon, UK) with an externally modifiable trigger delay was used. An analogue signal was outputted from the ventilator when inspiratory effort was detected and when the ventilator delivered pressure to the airways. This analogue signal was converted to a digital signal using the Powerlab analogue to digital converter (AD Instruments, Chalgrove, Oxford) and recorded in concert with the assessment of participant and ventilator interaction. (Figure 64).

Twenty different trigger delay settings were assessed in all participants ranging from 10ms to 1000ms. Each study participant received non-invasive ventilation with a set trigger delay over a 2 minute epoch. To ensure reproducibility each participant received the 20 trigger delay settings twice in a randomised order. Sealed envelope randomisation was performed by an independent member of the research team. All participants received non-invasive ventilation for 10 minutes prior to starting the study to acclimatise to the ventilator before any trigger delay was imposed. During this time, adjustments to the mask interface were made to maximise comfort and minimise leak. Leak was assessed from close examination of flow traces obtained at the mask during a breath hold performed at the end of expiration.

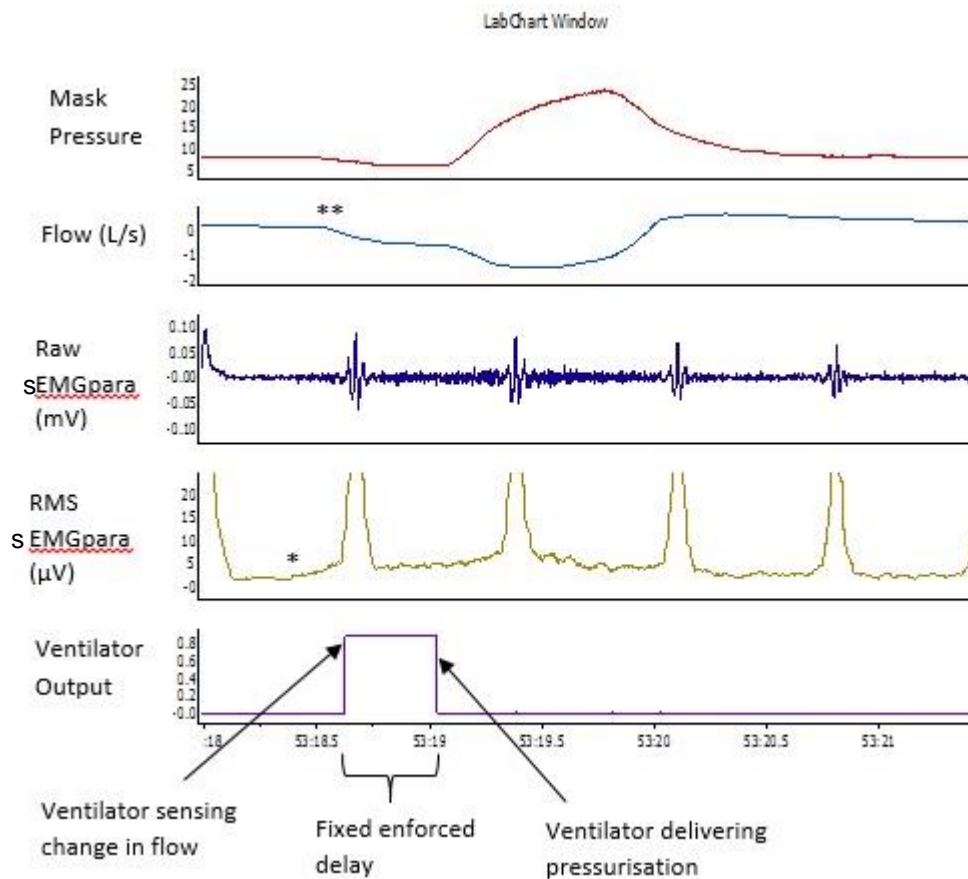
Second intercostal parasternal surface electromyography was performed throughout the study (as described in material and methods chapter 2- 2.7.1). This was used as a marker of both the onset of inspiratory effort and the inspiratory muscle load imposed during each trigger delay setting. Flow was measured through a heated Hans Rudolph pneumotach (flow 0-400L/min) (Shawnee, KS, USA) that was placed proximal to the exhalation valve in the ventilator circuit adjacent to the mask (Figure 64). The pneumotach was calibrated prior to each study using a standardised 3 litre volumetric syringe kept to within the recommended  $\pm 15$ ml error margin.<sup>(190)</sup> Measurements of tidal volume were obtained ensuring less than a 3% variability between breaths as recommended by the ATS/ERS task force.<sup>(190)</sup> Mask pressure was also recorded throughout the study as a marker of the ventilator response to subject triggering. An example of these recordings obtained from a single subject at two trigger delay settings (50ms and 900ms) is demonstrated in Figure 65.

In addition to measuring the peak sEMGpara%max during each 2 minute trigger delay epoch, the traces were closely examined to identify 5 breaths per epoch in which measurements of the time

between the onset of sEMGpara contraction and the activation of the ventilator flow trigger could be assessed.

Transcutaneous capnometry and oximetry were measured throughout the study. Transcutaneous carbon dioxide (TcCO<sub>2</sub>) and oxygen saturations (SpO<sub>2</sub>) were controlled by changes in the driving pressure of the ventilator (inspiratory positive airways pressure) to maintain the TcCO<sub>2</sub> and SpO<sub>2</sub> within the subject's baseline values with the TcCO<sub>2</sub> limit set at 0.5 kPa and SpO<sub>2</sub> limit set at 4%. This was primarily to minimise the influence of the hypercapnic and hypoxic drive to breathe.

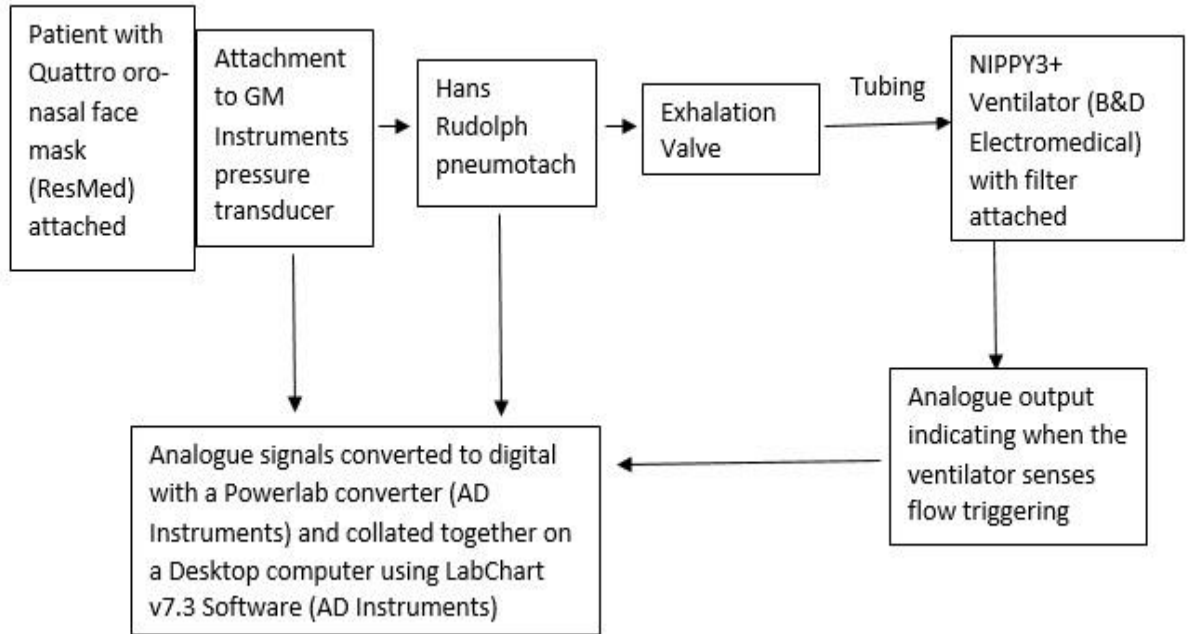
**Figure 61: An example of the analogue delay output from the custom made NIPPY3+ ventilator measured in concert with the measures of patient ventilator interaction**



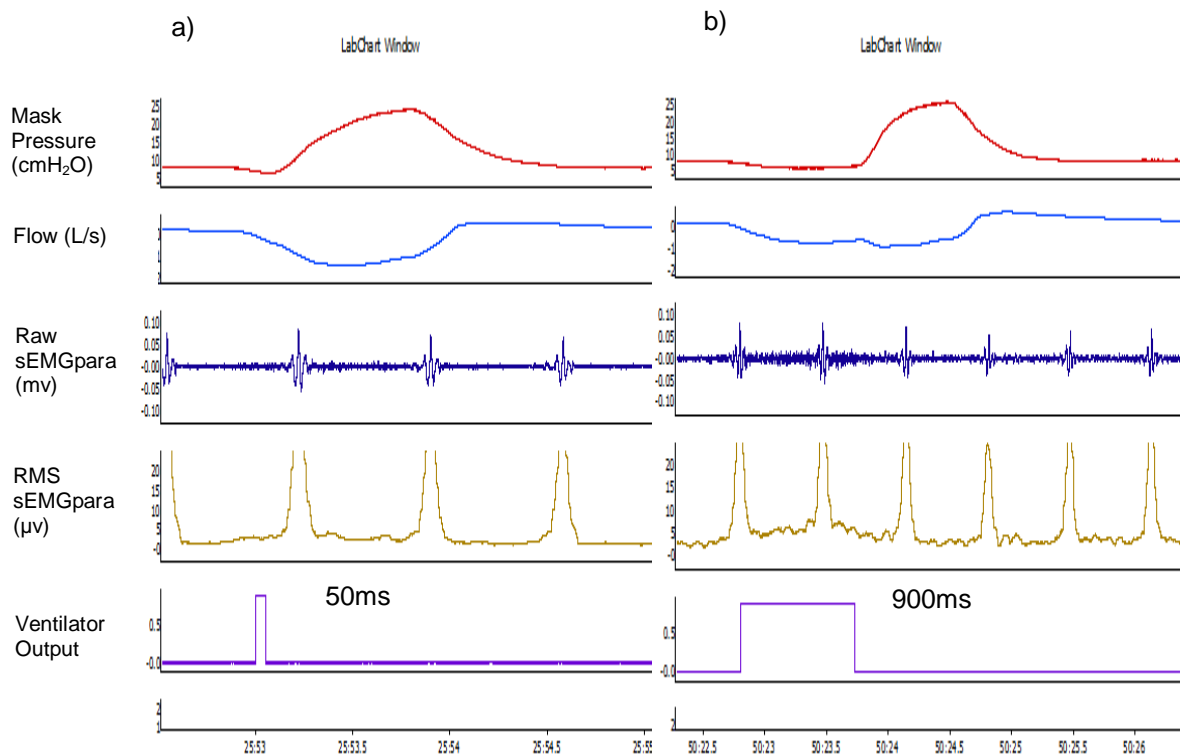
**Legend:** \*start of second intercostal parasternal muscle activity; \*\*start of change in flow at the mouth generated by patient

**Abbreviations:** sEMGpara- second intercostal parasternal surface electromyogram, RMS- root mean square of the raw parasternal electromyogram signal, mV-millivolts, µV-microvolts, L/s-litres per second.

**Figure 62: An example of the ventilator-circuit set-up used to assess ventilator trigger delay**



**Figure 63: An example of the raw traces obtained from a single COPD subject at a trigger delay of a) 50ms and b) 900ms demonstrating both the delay in the ventilator pressurisation and the increased parasternal muscle recruitment.**



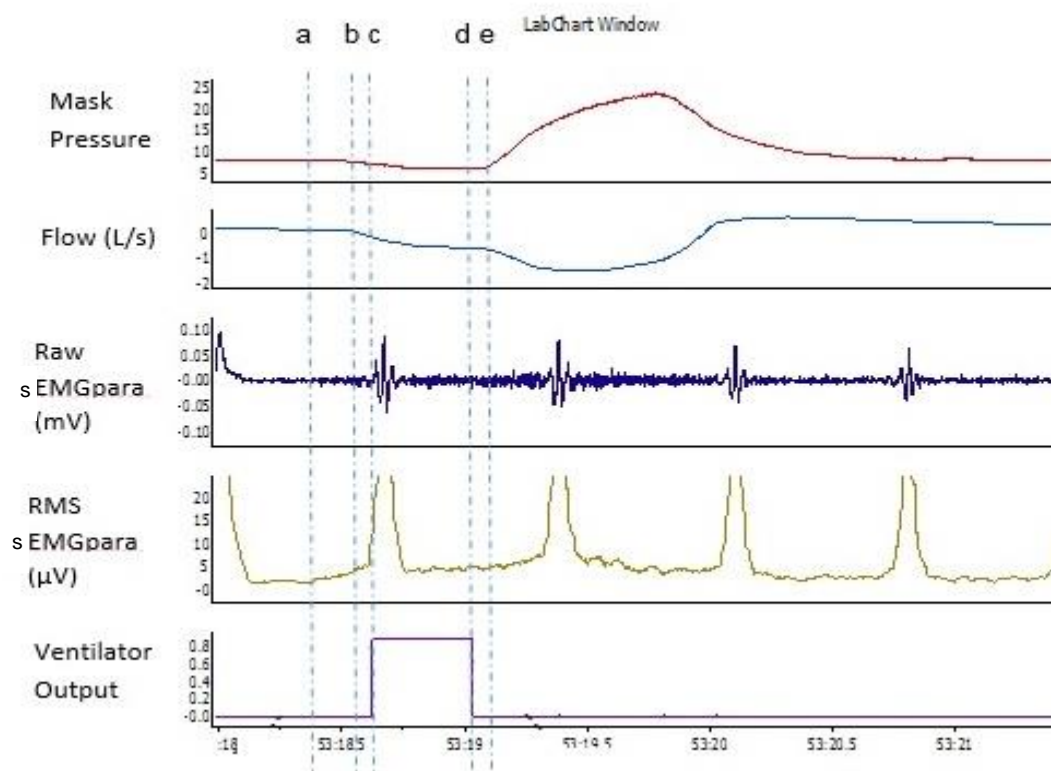
*Abbreviations:* sEMGpara- second intercostal parasternal surface electromyogram, RMS- root mean square of the raw parasternal electromyogram signal, mV-millivolts,  $\mu$ V-microvolts, L/s-litres per second.

### Measuring components of trigger delay

The delay from the initiation of a breath by the patient to the delivery of the breath by the ventilator is made up of multiple components that can be measured: i) the intrinsic subject delay: from onset of neural respiratory drive to onset of inspiratory flow at the mouth, ii) the trigger sensing delay: from flow generation by the patient to ventilator triggering, iii) the enforced trigger delay: extrinsic trigger delay inserted for the purposes of this study and iv) the ventilator mechanical delay: the delay in delivering the breath to the patient once triggering has occurred. (See Figure 66). Using our bespoke NIPPY3+ ventilator (B&D Electromedical, Stratford –upon-Avon, UK) adapted to output an electrical signal when the ventilator sensed triggering had occurred we were able to examine all of these components to identify precisely where trigger

delay occurred. In this way, we could compare delays due to individual pulmonary mechanics or ventilator inefficiencies between the participants in our study.

**Figure 64: Components of trigger delay identified**



**Legend: a-b: intrinsic subject delay; b-c: ventilator trigger sensing delay; c-d: enforced trigger delay; d-e: ventilator mechanical delay**

*Abbreviations:* sEMGpara- second intercostal parasternal surface electromyogram, RMS- root mean square of the raw parasternal electromyogram signal, mV-millivolts,  $\mu$ V-microvolts, L/s-litres per second.

### 6.2.2 Non-invasive ventilator settings

All the healthy subjects received NIV delivered by a modified NIPPY 3+ ventilator (B&D Electromedical, Stratford-upon-Avon, UK) in pressure support (PS) mode set with an inspiratory positive airway pressure (IPAP) of 12cmH<sub>2</sub>O and an expiratory positive airway pressure (EPAP) of 4 cmH<sub>2</sub>O. A back up rate was set at 6 breaths per minute, the lowest possible on the NIPPY 3+ ventilator (B&D Electromedical, Stratford-upon-Avon, UK) to ensure that the subjects triggered

all breaths from the ventilator. The inspiratory and expiratory trigger settings were set at 4 and 4 as is the recommended manufacture settings.

The COPD patients received NIV delivered by a modified NIPPY 3+ ventilator (B&D Electromedical, Stratford-upon-Avon, UK) in PS mode with an IPAP and EPAP set at the usual overnight settings of the patient. The back-up rate was also set at 6 breaths per minute, which was below the patient's nocturnal ventilator setting rate to ensure that the patients triggered all breaths throughout the study. All COPD patients in this study received non-invasive ventilation with inspiratory and expiratory trigger settings set at 4 and 4 to standardise the study.

### **6.2.3 Participant comfort measurements**

All study participants were blinded to the trigger delay settings asked to assess the perceived comfort of each setting using a 100mm visual analogue score (VAS) immediately post receiving a set trigger delay. A score of 100mm represented total comfort and a score of 0mm represented total discomfort.

### **6.2.4 Statistical analysis**

All data were non-parametric and is presented as median and inter-quartile range. Comparison of data between healthy subjects and COPD patients was performed using Mann-Whitney t-test. Spearman correlations were performed between trigger delay settings and participant outcome measures such as respiratory muscle loading or comfort scores. For all analyses, a p-value <0.05 was considered statistically significant.

## **6.3 Results**

### **6.3.1 Study Participants**

Fourteen healthy subjects were enrolled into the study with the baseline characteristics reported in Table 31. Four COPD patients were enrolled into this study, their demographics are reported in Table 32. COPD patients were older than the healthy controls (65 (61-68)years vs 35 (31-42)years;  $p < 0.001$ ) with, as expected, more obstructive spirometry ( $FEV_1$  21 (15-23)% vs 101 (92-117)%;  $p < 0.0001$ ), lower sniff nasal pressure (54 (39-69)cmH<sub>2</sub>O vs 77 (68-90)cmH<sub>2</sub>O;  $p < 0.004$ ) and higher resting neural respiratory drive (11.1 (9.0-22.7)%max vs 6.1 (3.9-6.7)%max;  $p < 0.01$ )

(Figure 67). There was no difference in the body mass index (BMI) between the COPD patients and the healthy subjects but, again as expected, COPD patients were more hypoxic and hypercapnic on room air prior to non-invasive ventilation (SpO<sub>2</sub> 94 (92-96)% vs 99 (99-100)%; p<0.0001, TcCO<sub>2</sub> 7.4 (6.7-8.0) kPa vs 4.8 (4.5-5.3) kPa; p<0.0001, respectively).

**Table 31 Demographics of healthy subjects**

No. (n)	Age yrs	Sex (M/F)	BMI kg/m <sup>2</sup>	FEV1% ratio	FVC% (%)	FEV1/FVC ratio (%)	SNIP cmH <sub>2</sub> O	tidal EMG raw (mV)	tidal EMG (%max)	Oxygen (%)	TcCO <sub>2</sub> (kPa)
1	32	F	24	127	139	79	79	5.4	4	99	4.5
2	27	F	20	83	93	78	60	2.6	6.2	100	4.6
3	28	F	20	92	100	81	67	14.3	8.4	100	4.8
4	63	F	30	145	148	81	91	2.8	6.7	100	4.8
5	32	M	27	109	106	80	73	4.3	6.4	99	4.8
6	49	F	19	101	114	76	70	4.6	7.1	99	4.9
7	59	M	25	133	120	87	93	5.7	4.4	99	5.3
8	28	M	22	114	107	91	96	5.9	6.7	100	4.2
9	34	M	25	94	94	83	68	4.1	5.9	99	5.4
10	39	M	23	82	73	93	64	2.3	3.3	100	5.5
11	32	F	22	113	128	77	84	4.4	6.6	100	4.5
12	36	M	23	100	90	75	88	2.7	3.7	99	4.5
13	39	F	21	100	93	94	74	4.6	2.8	99	5.1
14	35	M	26	92	97	79	89	6.4	4.7	98	5.4
Median	35		23	101	103	81	77	4.5	6.1	99	4.8
IQR	(31-42)		(21-25)	(92-117)	(93-122)	(78-88)	(68-90)	(2.8-5.8)	(3.9-6.7)	(99-100)	(4.5-5.3)

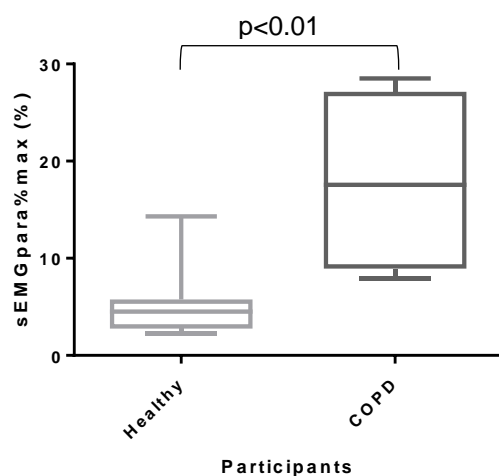
Results are expressed as median and standard deviation. *Abbreviations:* yrs =years, FEV1= forced expiratory volume in 1 second, FVC= forced vital capacity, SNIP= sniff nasal inspiratory pressure, EMG= second intercostal parasternal electromyogram, TcCO<sub>2</sub> =transcutaneous carbon dioxide, M-male, F-female, kPa-kilopascals, kg/m<sup>2</sup>-kilogram per metre squared.

**Table 32: Demographics of COPD patients**

No. (n)	Age yrs	Sex (M/F)	BMI kg/m <sup>2</sup>	FEV1% ratio	FVC% (%)	FEV1/FVC ratio (%)	SNIP cmH <sub>2</sub> O	tidal EMG raw (mV)	tidal EMG (%max)	Oxygen (%)	TcCO <sub>2</sub> (kPa)
15	64	M	22	23	37	44	65	12.0	12.9	92	8.0
16	69	M	26	23	45	47	43	23.1	9.3	94	7.0
17	65	M	19	19	37	39	70	7.9	8.9	96	6.6
18	60	M	24	14	37	31	38	28.5	25.9	93	7.8
Median	65		23	21	37	42	54	17.6	11.1	94	7.4
IQR	(61-68)		(20-26)	(15-23)	(37-43)	(33-46)	(39-69)	(8.9-25.1)	(9.0-22.7)	(92-96)	(6.7-8.0)

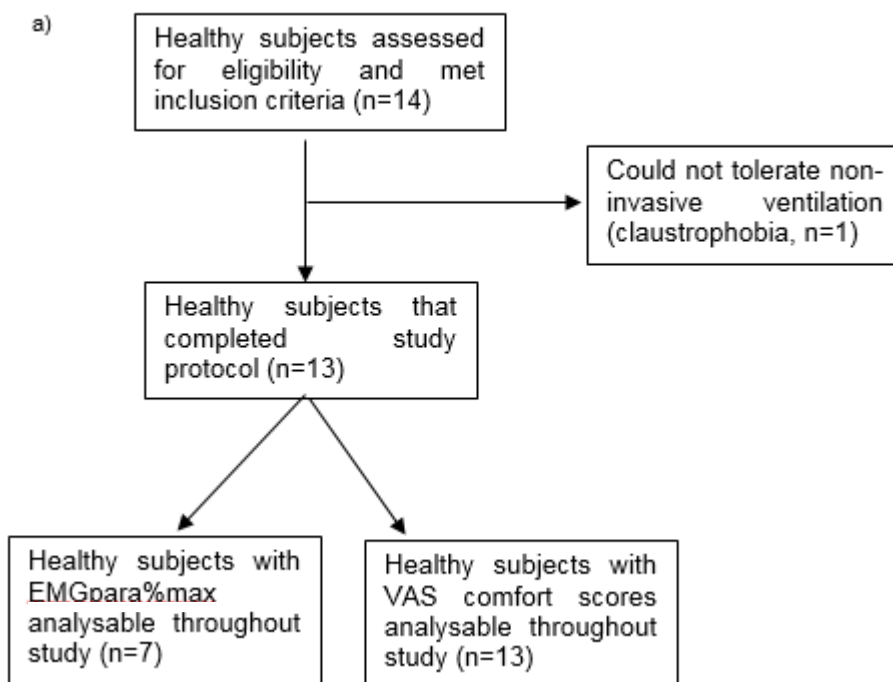
Results are expressed as median and interquartile range. *Abbreviations:* yrs =years, FEV1= forced expiratory volume in 1 second, FVC= forced vital capacity, SNIP= sniff nasal inspiratory pressure, EMG= second intercostal parasternal electromyogram, TcCO<sub>2</sub> =transcutaneous carbon dioxide, M-male, F-female, kPa-kilopascals, kg/m<sup>2</sup>-kilogram per metre squared.

**Figure 65: Box and Whisker plots comparing sEMGpara%max in 4 COPD patients and 14 healthy subjects' self-ventilating**

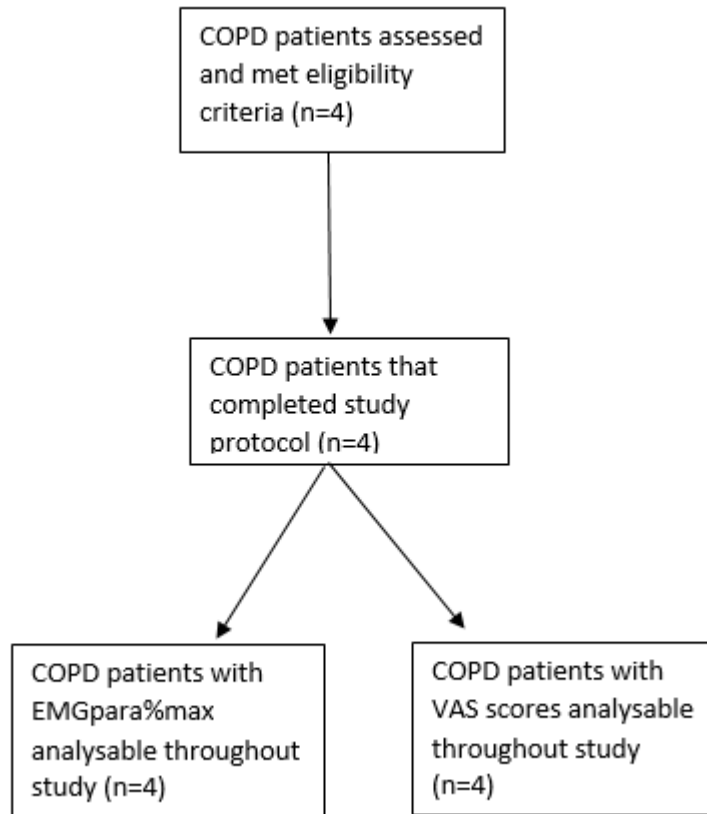


Data are represented with the mid line as the median, the box length representing the interquartile range and the whiskers as the minimum and maximum values. *Abbreviation:* sEMGpara%max-surface second intercostal parasternal electromyogram normalised to a maximal inspiratory manoeuvre.

**Figure 66: Study flow diagram a) healthy subjects and b) COPD patients**



b)



All COPD patients tolerated the full protocol of the study. 13 of the 14 healthy subjects managed the full study protocol; one subject discontinued due to claustrophobia 20 minutes into the study. Of the remaining 13 healthy subjects that completed the study protocol, all provided self-reported comfort data using a visual analogue scale, however, only 7 subjects had a sEMGpara signal that was analysable above noise levels throughout the whole study on ventilation; (#1, #3, #5, #6, #11, #13 and #14). The healthy subjects that had an analysable signal throughout the study had a higher raw sEMGpara signal during tidal breathing compared to those healthy subjects where the raw sEMGpara signal was not able to be analysed when non-invasive ventilation was started, (17.6 (8.9-25.1) mV vs. 4.5 (2.8-5.8) mV;  $p=0.07$ ).

### 6.3.2 The effect of trigger delay on sEMGpara%max

There was no difference observed in the sEMGpara%max between round 1 and round 2 in either the healthy subjects or COPD patients ( $p=0.99$  and  $p=0.99$ , respectively). In view of this the data presented in this chapter are the combined sEMGpara%max for both round 1 and 2 at each of the 20 different delay settings.

Figure 67: sEMGpara%max measured with increasing trigger delay settings in healthy subjects

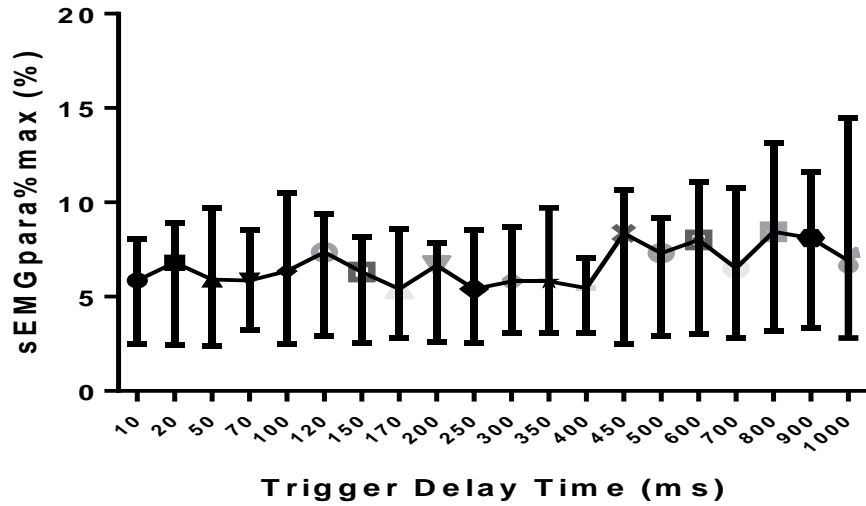


Table 33: Individual sEMGpara%max in response to increasing trigger delay in healthy subjects

No. (n)	10	20	50	70	100	120	150	170	200	250	300	350	400	450	500	600	700	800	900	1000
1	2.2	2.4	2.4	3.2	2.4	2.9	2.4	2.7	2.5	2.5	3.0	2.9	3.2	2.4	3.1	2.8	2.8	3.0	3.1	2.8
3	8.5	8.6	7.9	7.5	6.4	8.2	7.5	5.4	6.8	7.9	8.5	7.2	6.3	9.9	10.4	9.4	11.2	11.9	9.7	10.1
5	6.1	8.9	6.9	7.0	11.3	10.0	7.4	7.3	9.9	6.8	7.2	7.5	6.2	8.5	7.4	13.0	6.5	8.5	9.9	8.7
6	7.6	6.8	10.5	7.5	11.7	8.5	7.9	10.0	6.9	8.4	6.6	10.0	6.3	12.4	7.7	10.2	15.1	13.8	11.8	14.6
11	8.8	9.9	9.9	10.5	8.1	8.9	8.4	8.7	8.8	9.4	10.9	13.4	8.9	11.1	13.1	11.2	10.3	14.1	11.7	20.8
13	2.0	1.8	1.9	1.8	1.7	1.8	1.7	1.9	1.7	1.6	1.5	1.9	1.7	1.9	2.3	1.9	1.8	1.8	2.0	2.0
14	3.2	3.2	4.5	3.5	3.8	3.3	3.3	3.4	3.6	3.4	3.9	3.6	3.6	3.8	3.6	3.3	4.6	3.9	3.8	3.9
Median	5.9	6.8	5.9	5.9	6.4	7.4	6.3	5.4	6.7	5.4	5.8	5.8	5.5	8.4	7.3	8.0	6.5	8.5	8.1	6.9
IQR	(2.5-8.1)	(2.5-8.1)	(2.4-9.7)	(3.2-8.6)	(2.5-10.5)	(2.9-9.4)	(2.6-8.2)	(2.8-8.6)	(2.6-7.8)	(2.6-8.6)	(3.1-8.7)	(3.1-9.7)	(3.1-7.1)	(2.5-10.7)	(2.9-9.2)	(3.0-11.1)	(2.8-10.8)	(3.2-13.2)	(3.3-11.6)	(2.8-14.5)

Figure 68: sEMGpara%max in response to increasing trigger delay settings in COPD patients

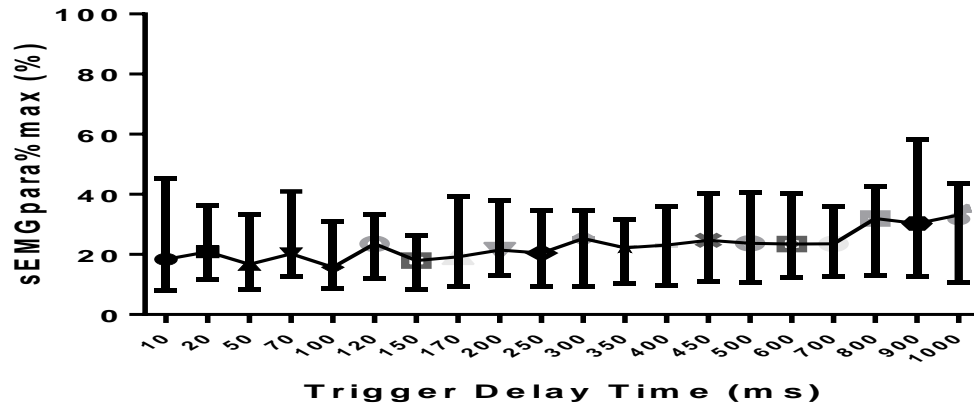


Table 34: Detailed individual sEMGpara%max response to 20 increasing trigger delay settings (ms) in 4 COPD patients combined

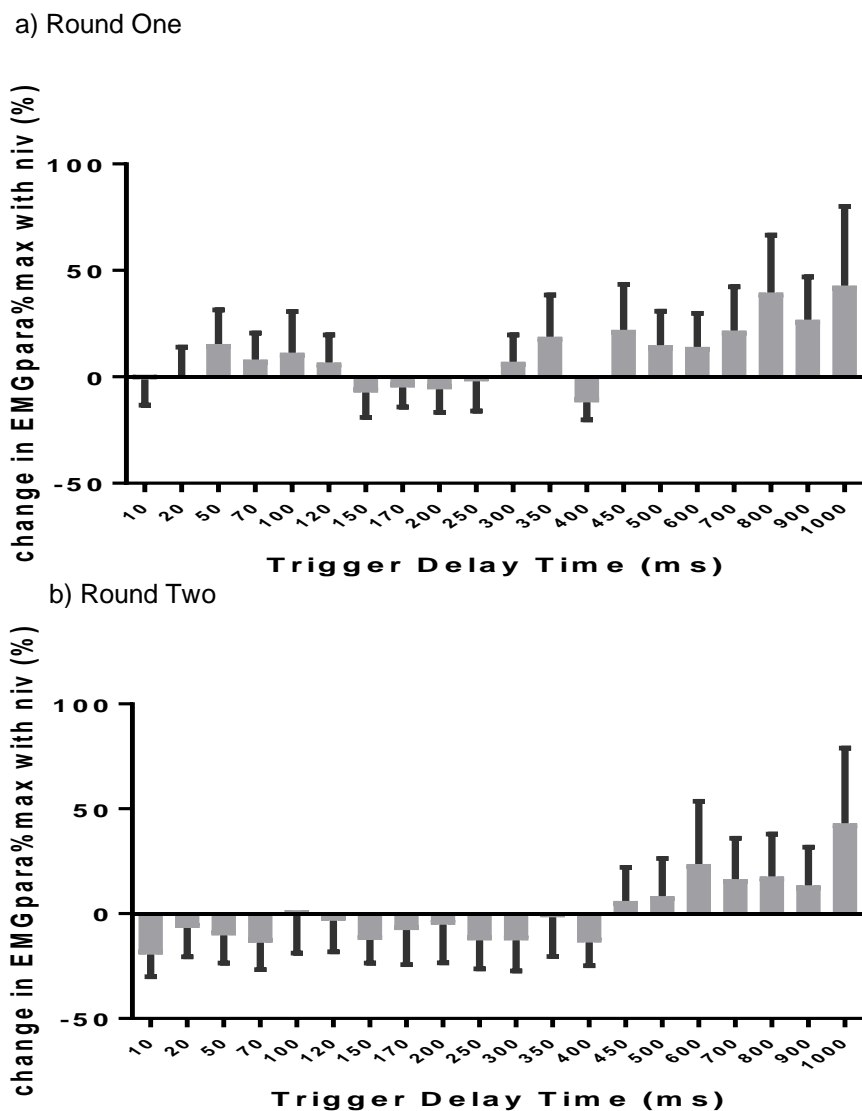
No	10	20	50	70	100	120	150	170	200	250	300	350	400	450	500	600	700	800	900	1000
15	53.7	41.0	35.6	49.7	29.5	42.4	36.5	46.3	44.0	39.7	42.6	40.4	43.1	51.4	45.6	47.8	42.0	55.1	67.2	61.1
16	15.8	15.0	10.4	14.7	14.1	17.5	13.9	12.3	13.8	13.2	16.1	15.8	16.4	17.6	14.3	15.1	17.5	19.7	19.2	22.1
17	5.9	8.4	7.4	10.7	6.0	8.3	6.6	9.5	9.1	8.8	8.0	9.0	7.9	10.2	8.3	13.0	10.7	13.2	12.9	10.7
18	23.0	26.7	27.0	25.0	30.6	30.5	20.3	25.8	30.2	28.6	33.1	29.1	29.1	28.9	31.6	28.2	35.1	40.5	37.0	42.0
Median	18.3	20.8	16.7	20.2	15.7	23.6	17.9	19.2	21.5	20.4	25.3	22.2	23.1	24.7	23.7	23.5	23.6	31.9	30.3	33.1
IQR	(7.9-45.3)	(11.8-36.4)	(8.4-33.2)	(12.8-40.9)	(8.8-31.0)	(12.1-33.2)	(8.4-26.3)	(9.4-39.4)	(12.9-37.9)	(9.4-34.4)	(9.4-34.4)	(10.4-31.8)	(9.7-36.0)	(11.1-40.2)	(10.7-40.7)	(12.4-40.2)	(12.6-36.0)	(13.0-36.0)	(12.8-58.4)	(10.8-43.5)

No statistically significant difference was observed between neural respiratory drive between any of the 20 trigger delay settings in healthy subjects ( $p > 0.99$ ). No statistically significant difference was observed in this study between neural respiratory drive levels at any of the 20 trigger delay settings in COPD patients ( $p > 0.99$ ).

### 6.3.3 Respiratory muscle loading in healthy subjects and COPD patients with increasing trigger delay

Compared with self-ventilating healthy subjects increased respiratory muscle loading was consistently demonstrated with inspiratory trigger delays above 450ms. More variability in respiratory muscle loading was observed in round 1 than round 2. (Figure 71).

**Figure 69: Respiratory muscle loading and unloading in healthy subjects on non-invasive ventilation with increasing trigger delay**

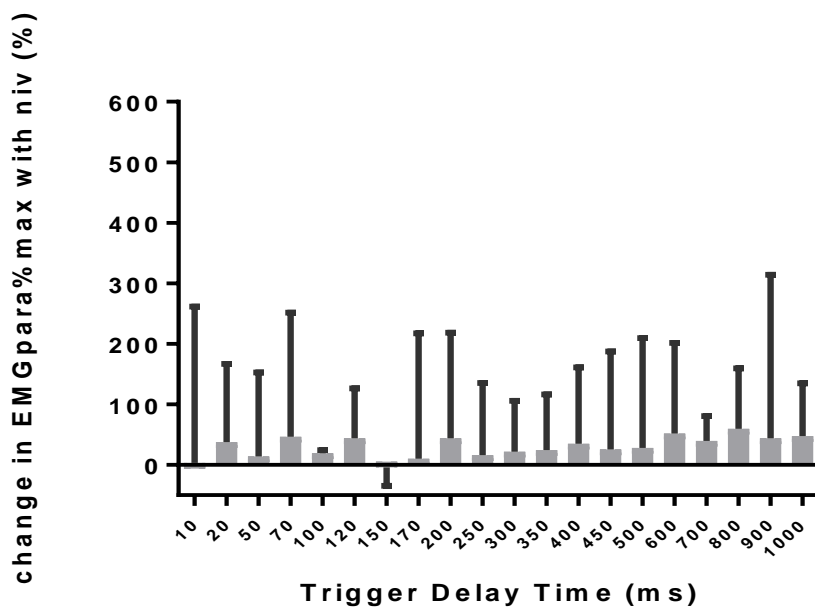


Patients with COPD did not achieve respiratory muscle unloading on non-invasive ventilation with trigger delay. Even with small trigger delays COPD patients demonstrated an increased in respiratory muscle recruitment compared with self-ventilation. (Figure 72). COPD patients experienced increased respiratory muscle loading than healthy subjects at all trigger delays.

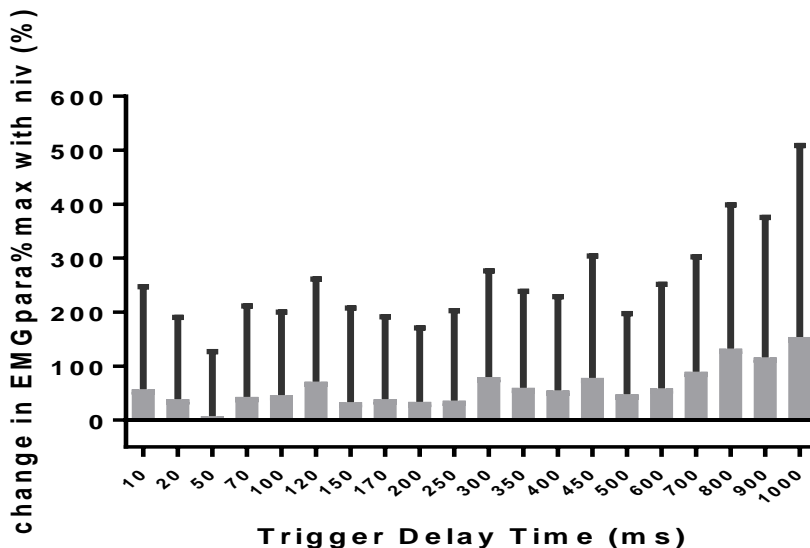
Furthermore, as expected, the longer the trigger delay the larger the increase in respiratory muscle loading observed, although this did not reach statistical significance.

**Figure 70: A graph of respiratory muscle loading and unloading in COPD patients on non-invasive ventilation with progressive increasing trigger delays**

a) Round One



b) Round Two



### 6.3.4 The effect of trigger delay on comfort scores

#### *Healthy Subjects*

There was no significant difference observed between the comfort scores obtained in healthy subjects in round 1 and round 2 at any of the ventilator delay settings. Combining the comfort scores from both rounds together, a peak median comfort scores of 84 (62-92) and 84 (67-88) were measured at 120ms and 150ms trigger delay, respectively. Longer and shorter trigger delays were increasingly more uncomfortable. The least comfortable trigger delay setting was measured at 1000ms with a combined median comfort score of 58 (33-76). (Figure 73a).

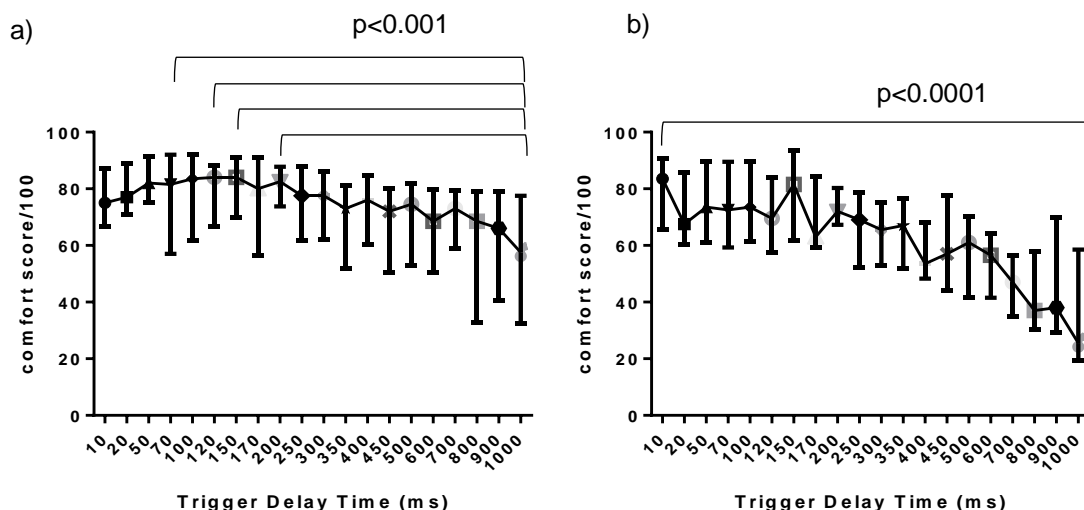
A significant difference was shown between the comfort settings (1-way ANOVA,  $p < 0.001$ ). Comfort scores at 50ms, 120ms, 170ms and 200ms trigger delays were significantly more comfortable than at 1000ms (Dunns multiple comparison test).

#### *COPD patients*

There was no difference observed between the comfort scores recorded by COPD patients at different trigger delay settings in round 1 and round 2. Combining the comfort scores for round 1 and 2 together, COPD patients perceived increased comfort at shorter trigger delay settings, with a peak median comfort score of 84 (66-91) at a trigger delay of 10ms. A reduction in comfort scores was observed at longer trigger delays in COPD patients with maximal discomfort detected at 1000ms trigger delay.

A statistically significant difference was shown in combined comfort scores between the trigger delay settings ( $p < 0.0001$ ), investigating the differences (Dunn's multiple comparisons tests) this was driven by a difference between comfort scores at 10ms; comfort score 84 (66-91) and 1000ms; comfort score 26 (19-59) respectively. (Figure 73b).

**Figure 71: Combined round 1 and 2 comfort scores for a) healthy controls and b) COPD patients**

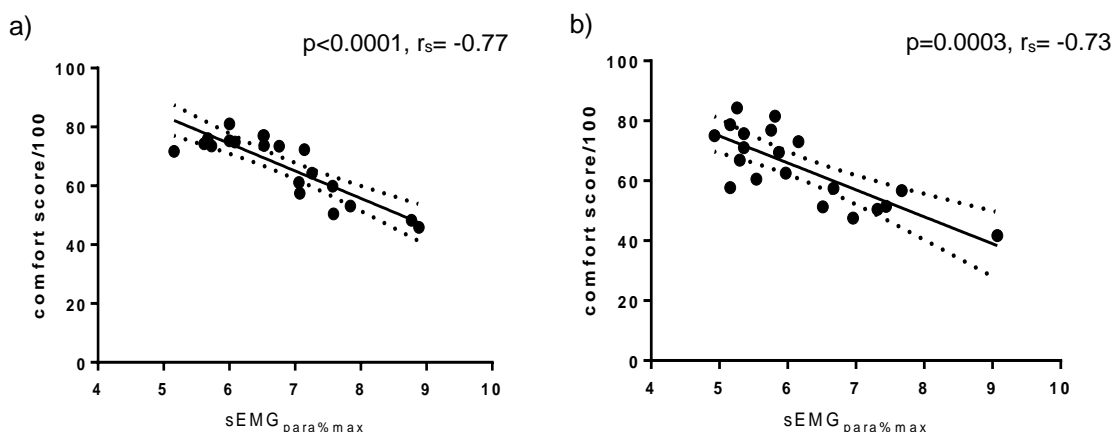


Data shown as median and IQR

### 6.3.5 The relationship between respiratory muscle loading and perception of comfort

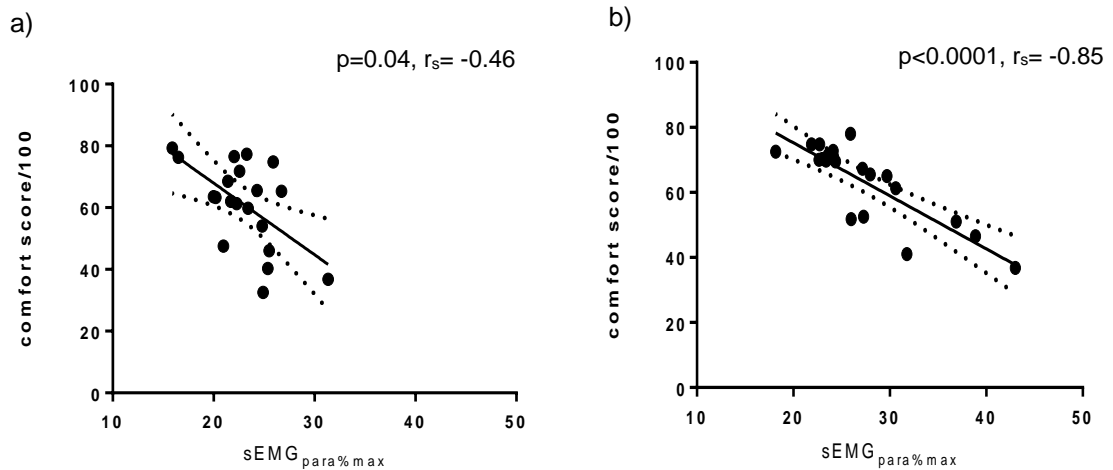
When considering which factors are driving the perception of comfort or discomfort in this study, we analysed the relationship between respiratory muscle loading (defined as increasing sEMGpara%max) and comfort scores. Analysing those subjects for which respiratory muscle electromyography was available, respiratory muscle loading (mean sEMGpara%max) was shown to be negatively correlated with mean comfort perception in both healthy subjects and patients with COPD. (Figures 74 and 75).

**Figure 72: Relationships between mean comfort perception and respiratory muscle loading in healthy subjects during a) round one and b) round two**



*Abbreviations:* sEMGpara%max-surface parasternal electromyogram normalised to a maximal inspiratory manoeuvre.

**Figure 73: Relationships between mean comfort perception and respiratory muscle loading in COPD patients during y a) round one and b) round two**



*Abbreviations:* sEMGpara%max-surface parasternal electromyogram normalised to a maximal inspiratory manoeuvre.

### 6.3.6 Considering the components of the trigger delay

Intrinsic subject delay was significantly longer in patients with COPD than healthy subjects. However, trigger sensing delay was significantly longer in healthy subjects compared to patients with COPD. Overall, this led to a longer total delay between the initiation parasternal muscle electrical activity and the delivery of pressure support by the ventilator in healthy subjects. There was no significant difference between the ventilator mechanical delay between COPD patients and healthy subjects. (Table 35).

**Table 35: Breakdown of trigger delay (excluding enforced trigger delays) in both healthy subjects and COPD patients**

	<b>Healthy Subjects</b>	<b>COPD patients</b>	<b>p-value</b>
<b>Component of trigger delay</b>	Time (ms)	Time (ms)	
<b>i) Intrinsic subject delay</b>	115 (78-144)	129 (104-156)	p<0.001
<b>ii) Trigger sensing delay</b>	177 (109-266)	112 (96-122)	p<0.001
<b>iv) Ventilator mechanical delay</b>	50 (30-70)	36 (30-48)	p=0.21
<b>Total delay</b>	362 (274-432)	279 (248-308)	p<0.001

279 (248-308) milliseconds of the total inspiratory time of the COPD patients was made up of delays in interacting with the ventilator. This is equivalent to 16 (13-19) % of the time that the parasternal inspiratory muscles are activated, during which time there is no pressure support being provided from the ventilator. The largest component of inspiratory delay in COPD patients was related to the intrinsic delay between initiation of the parasternal muscle electrical activity and generating inspiratory airflow at the patient's mouth 7 (6-9)% of inspiratory time. (Table 36). Healthy subjects have less overall delay 14 (11-19)% as a proportion of time that the parasternal muscles are activated. For healthy subjects the longest inspiratory delay is related to the trigger sensing delay which is responsible for 7 (4-11)% of the total neural inspiratory time. Reassuringly, the ventilator mechanical delay was similar in both COPD patients and healthy controls, responsible for just 2% of the overall neural inspiratory time.

**Table 36: Impact of trigger delays on the total inspiratory time: percentage of time for which unrewarded parasternal respiratory muscle activity occurs**

	Healthy Controls	COPD patients
Trigger delays as a percentage of the total neural inspiratory time		
Intrinsic delay (%)	4 (3-6)	7 (6-9)
Trigger sensing delay (%)	7 (4-11)	6 (5-8)
Ventilatory mechanical delay (%)	2 (1-3)	2 (1-3)
Total delays (%)	14 (11-18)	16 (13-19)

In an effort to explain the differences observed between the intrinsic delay and the trigger sensing delay between healthy subjects and COPD patients further we investigated the breathing characteristics of each study participant whilst on non-invasive ventilation. We could demonstrate that COPD patients had a statistically significant shorter neural inspiratory time than healthy subjects during the study ( $p < 0.001$ ), despite the enforced extension of inspiratory time related to trigger delay. In keeping with this the respiratory rate of the COPD patients was faster than the healthy subjects whilst receiving NIV ( $p = 0.02$ ). The rate of change of inspiratory flow generated by COPD patients was greater than that achieved by healthy subjects ( $p < 0.001$ ). The unintentional leak recorded at the mask was not significantly different between the groups of participants.

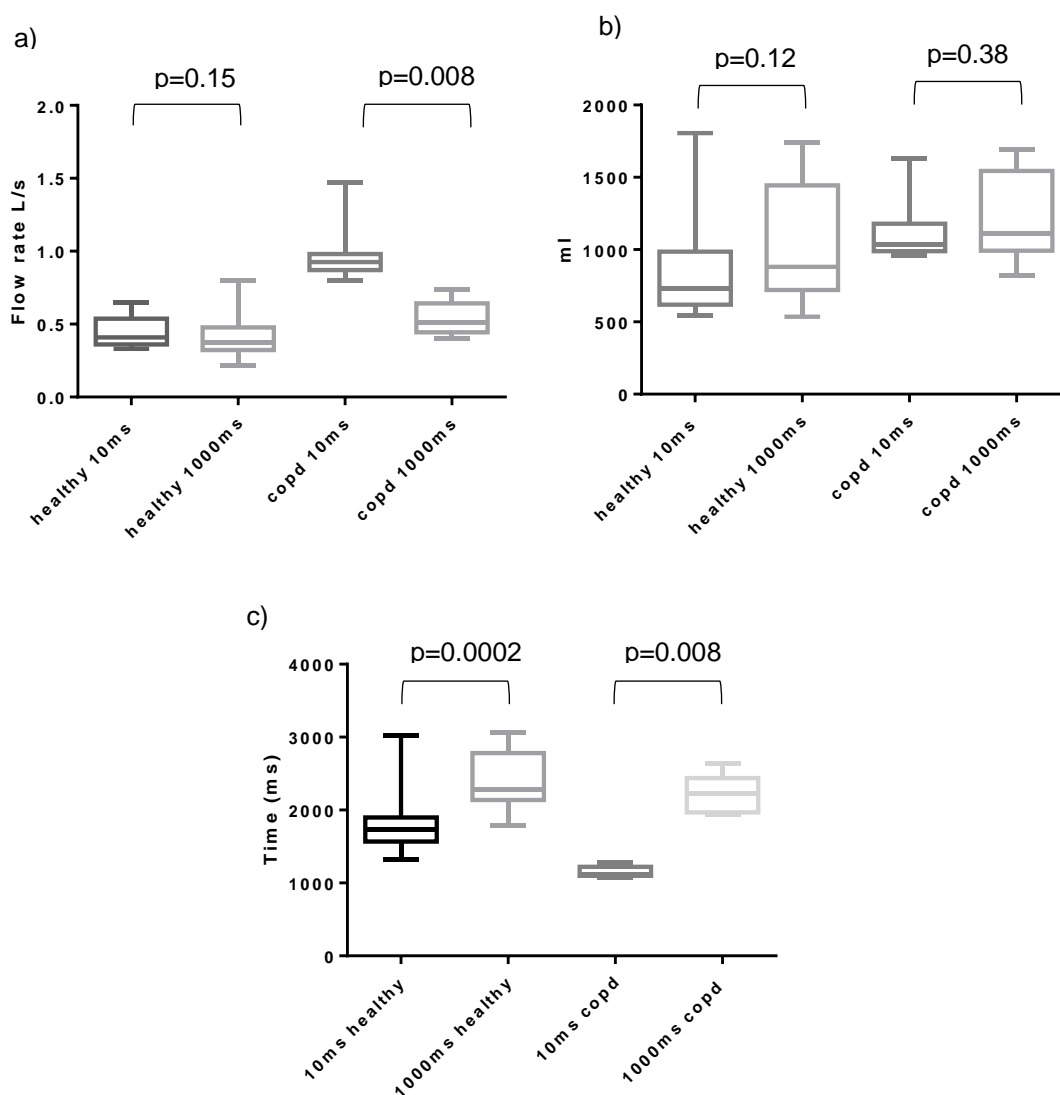
Neuroventilatory efficiency was significantly reduced in COPD patients indicating that increased respiratory muscle recruitment is required to generate a tidal volume ( $p < 0.0001$ ). However, the percentage of neural time used to generate inspiratory flow was similar between participants.

**Table 37: Breathing characteristics when subject to trigger delay on non-invasive ventilation**

<b>Breathing characteristics</b>	<b>Healthy Subjects</b>	<b>COPD patients</b>	<b>p-value</b>
<b>Neural inspiratory time (ms)</b>	2368 (2021-2902)	1783 (1540-2072)	<0.001
<b>Inspiratory flow time per neural inspiratory time (%)</b>	80 (68-90)	82 (73-93)	0.06
<b>Inspiratory flow rate (L/s)</b>	0.32 (0.27-0.40)	0.62 (0.54-0.71)	<0.001
<b>Neuroventilatory efficiency (ml/<math>\mu</math>V)</b>	136 (98-161)	34 (25-99)	<0.0001
<b>Mask leaks (mL/s)</b>	25 (19-50)	26 (19-57)	0.80
<b>Respiratory rate (n/min)</b>	11 (11-12)	13 (12-14)	0.02

*Abbreviations:* COPD=chronic obstructive pulmonary disease, ms-milliseconds, L/s-litre per second, ml-millilitres,  $\mu$ V-microvolts, mL/s-millilitres per second, n/min-number per minute.

**Figure 74: Change in a) inspiratory flow rate b) tidal volume and c) inspiratory time observed between 10ms and 1000ms inspiratory trigger delay in healthy subjects and COPD patients**



*Abbreviations:* copd-chronic obstructive pulmonary disease patients, healthy- healthy subjects, ms- milliseconds, ml-millilitres, L/s-litres per second.

A significant reduction flow rate was observed in COPD patients between 10ms and 1000ms inspiratory trigger delays ( $p=0.008$ ). This was driven by the increase in inspiratory time rather than any limitation of the tidal volume. Healthy subjects had much slower inspiratory flow rates at 10ms trigger delays compared to COPD patients ( $p<0.0001$ ).

There was no difference in the coefficient of variation between healthy and COPD subjects in terms of flow rate or inspiratory time (0.28 vs 0.25 and 0.24 vs 0.22, respectively). More than a

three-fold difference was observed between the coefficient of variation in tidal volume between healthy and COPD patients (0.85 vs 0.24).

## **6.4 Discussion**

### **6.4.1 Main findings**

The current study was supportive of previous data in the literature suggesting that sEMGpara%max is higher in COPD patients than healthy controls during resting breathing.(132) In addition, this study demonstrated that respiratory muscle activity is not effectively unloaded whilst on non-invasive ventilation with trigger delay in COPD patients, whereas healthy subjects achieve consistent respiratory muscle loading only when a trigger delay of 450ms was imposed. There was no difference in neural respiratory drive, as measured by sEMGpara%max, with increasing trigger delays in healthy subjects with only a 1% increase in neural respiratory drive between 10ms and 1000ms trigger delay. Furthermore, there was no difference observed in respiratory muscle loading with increasing trigger delay in COPD patients, albeit the neural respiratory drive increased from 18.3% (7.9-45.3%) at 10ms delay to 33.1% (10.8-43.5%) at 1000ms delay. These findings suggest that COPD patients that already have substantial loading of the respiratory muscles are less able to cope with the extra workload placed upon the respiratory system from an inspiratory trigger delay than healthy subjects.

Comfort scores were inversely related to neural respiratory drive in both healthy and COPD subjects, supporting the hypothesis that that increased respiratory muscle loading causes poorer perception of comfort whilst receiving non-invasive ventilation. Previous studies have demonstrated a close direct correlation between exercise induced perception of breathlessness and the levels of neural respiratory drive measured by respiratory muscle electromyography in patients with COPD and cystic fibrosis as well as healthy controls.(127, 191, 192) As a simple bedside monitoring tool, measuring sEMGpara%max could be used to assess patient comfort whilst receiving non-invasive ventilation overnight and assist the physician in tailoring settings to improve individual patient-ventilator interaction. Such an approach has recently been demonstrated in patients on the general intensive care unit receiving invasive mechanical

ventilation and could conceivably act as a physiological biomarker of patient comfort on non-invasive ventilation.(193)

#### **6.4.2 Critique of the method**

Measurement of neural respiratory drive, using sEMGpara, in healthy individuals receiving non-invasive ventilation is challenging. In this study, we have demonstrated that measurable raw sEMGpara signals above the level of electrical noise were only possible in half of the healthy subjects recruited following application of non-invasive ventilation. The small number of participants with fully analysable sEMGpara data could have resulted in a type 2 error in the neural respiratory drive analysis with increasing trigger delays. This study was, however, performed as a feasibility study to identify if COPD patients could tolerate being subjected to trigger delays whilst receiving non-invasive ventilation and to better understand the components of trigger delay facing patients during their interaction with non-invasive ventilation.

Every effort was made to ensure that participants were seated comfortably at 45 degrees with their arms and back well supported during the study in a posture that has previously been validated when obtaining sEMGpara%max measurements.(124) Due to the 2.5 hour length of the study, it is possible that posture varied slightly, which may have influenced the parasternal signal recordings. The electrodes were not removed between the two runs of the protocol and the recordings were visually inspected to exclude motion artefact in the analysis.

Although a thirty minute break from the ventilator was taken by each participant between round 1 and round 2 of the trigger delay protocol, the levels of neural respiratory drive observed in the second round may have been influenced by the previous hour on non-invasive ventilation. Reassuringly, there were no differences in the neural respiratory drive measured at the different 20 trigger delay settings between the two rounds in either health controls or COPD subjects. For this reason, it was reasonable for the results from round 1 and round 2 to be combined.

Although the trigger delay settings were randomly assigned, it is possible that comfort perceived by the subjects participating in this study was influenced by the previous trigger settings. Furthermore, healthy subjects may have acclimatised more to non-invasive ventilation in the second round impacting on their perception of comfort. For this reason, we repeated the study twice and reassuringly found that there was no difference in the comfort scores obtained between round one and round two when the order of trigger delay settings were different.

As discussed previously, the  $sEMG_{para\%max}$  is based on the peak EMG activity of the parasternal muscle normalised for the EMG activity during a maximum sniff manoeuvre. This may not be wholly reflective of the total parasternal inspiratory muscle activity. An improvement on the current measurement would be to measure the area under curve of the EMG, however currently the electrocardiogram (ECG) artefact makes this not possible. Developments are currently underway with complex signal processing to remove ECG artefact from the parasternal signal but this is beyond the scope of this thesis.

Unintentional mask leak was measured in all subjects at the beginning of each round of trigger delay settings. The mean of three independent measurements obtained during a breath hold manoeuvre in end expiration were reported in this study. Every effort was made to ensure that leaks from the mask were addressed by the research team throughout the studies as they occurred. Leak is a dynamic process and so it is possible that higher levels of leak may have occurred during the study that would have independently interfered with the ventilator inspiratory trigger sensing.

The ventilator pressure support applied to all healthy subjects was the same. As not all healthy subjects were the same age and height similar pressures may have resulted in either suboptimal tidal volumes or overinflating the respiratory system. For a future study it may be more appropriate to use a set ml/kg ideal body weight for each participant. Finally, we must acknowledge that the healthy subjects were not age and gender matched to the COPD patients. Thus, differences in neural respiratory drive observed in the COPD patients may have been, in part, as a result of the healthy subjects being younger and female, than their COPD counterparts.

#### **6.4.3 Respiratory muscle response to increasing inspiratory trigger delays on non-invasive ventilation**

COPD patients experience expiratory flow limitation with associated static and dynamic hyperinflation and intrinsic positive end expiratory pressure. These adverse pulmonary mechanics lead to respiratory muscle mechanical disadvantage and increased loading of the respiratory muscles, which in turn leads to increased neural respiratory drive as more muscle fibres are recruited to cope with the load placed upon them.(45, 46, 194) Direct output from the respiratory centres in the brainstem is difficult to measure but neural respiratory drive can be

measured indirectly through the respiratory muscle electromyogram that provides a method of assessing the level of muscle activation and recruitment required to meet the load placed upon the respiratory muscles.

The main aims of non-invasive ventilation include the correction of hypoventilation and to assist the respiratory muscle unloading.(53, 195) Inappropriate ventilator settings, may result in 'under-assistance' of the respiratory muscles or 'over-assistance' which can lead to PVA.(13, 148) Both of these situations may counterproductively increase the load upon the respiratory muscles and lead to an increase in neural respiratory drive in the extra-diaphragmatic respiratory muscles. This is often a dynamic process and so monitoring the levels of neural respiratory drive can guide the physician in optimising ventilator settings on an individual patient basis.(13)

Examining the change in neural respiratory drive between baseline self-ventilating and whilst on non-invasive ventilation suggests that healthy subjects achieve enhanced respiratory muscle unloading on non-invasive ventilation at trigger delays below 450ms, whilst all the COPD patients experienced an increase in respiratory muscle loading on non-invasive ventilation with even a short trigger delay. It is most likely that healthy subjects have increased capacity within their respiratory system to better tolerate the increasing load of trigger delay placed upon them. COPD patients are already facing considerable loads upon their respiratory system related to the underlying pathophysiology and so would naturally tolerate further unrewarded inspiratory efforts less well.

A final important consideration when understanding why COPD patients failed to effectively unload the respiratory muscles on non-invasive ventilation is the operating mechanics of the NIPPY3+ ventilator (B&D Electromedical, Stratford-upon-Avon, UK). The NIPPY3+ ventilator (B&D Electromedical, Stratford-upon-Avon, UK) is triggered in inspiration by the patient generating a threshold level of 'a rate of change of flow' at the mouth. The trigger settings on the ventilator range from 1-10 (10 most difficult) and are not a linear scale.(196) The trigger sensitivity settings for this study were set at the manufactures default of 4 for both inspiratory and expiratory triggering for consistency, which are also the settings used in our clinical practice. The rate of change of flow required to trigger the ventilator at different settings remains proprietary information. It is therefore possible that an inspiratory trigger setting of 4 is too insensitive for COPD patients resulting in the increasing sEMGpara%max whilst on NIV.

#### **6.4.4 Patient comfort with increasing inspiratory trigger delays on non-invasive ventilation**

Previous work by Vignaux *et al*, in acute respiratory failure suggested an association between impaired patient comfort as measured by a visual analogue scale and increased amounts of PVA on NIV.(89) Ventilator inspiratory trigger delays are known to increase the work of breathing, as respiratory muscles are activated for an extended period without receiving ventilatory support from the ventilator.(8) This would intuitively be less well tolerated by the patient resulting in the perception of discomfort. Patient comfort on NIV is often dependent on many factors such as mask tolerability, humidification, anxiety levels, the rate of ventilator pressurisation as well as patient ventilator synchronisation.(89, 197-199)

Healthy subjects were most comfortable on NIV with inspiratory trigger delays in the range of 120-150ms. Comfort declined with increasing trigger delays to a maximal discomfort at 1000ms. Interestingly, very short trigger delays were also more uncomfortable for healthy participants.

Trigger delay was well tolerated in healthy subjects, perception of comfort only fell 10 points below the peak comfort score when the inspiratory trigger delay exceeded 450ms. As the trigger delay increased, a wider IQR was observed suggesting more individual variability between in comfort perception at longer trigger delays.

COPD patients were most comfortable at the shortest inspiratory trigger delay setting of 10ms and as expected most uncomfortable at the longest trigger delay setting of 1000ms. An inspiratory trigger delay of 1000ms was much less well tolerated by COPD patients than by healthy controls with a median comfort score of 26 (19-59) vs 58 (33-76). Post an inspiratory trigger delay setting of 150ms comfort scores declined with increasing trigger delay settings.

For both healthy subjects and COPD patients comfort scores were negatively correlated with increasing sEMGpara%max signals. This finding demonstrates that increased respiratory muscle loading is related to a poorer perception of comfort whilst on non-invasive ventilation and importantly could be used as a tool to review the impact of changes in ventilator settings to optimise comfort for awake patients on non-invasive ventilation.

Patient comfort on non-invasive ventilation has not previously been directly associated with the levels of neural respiratory drive and respiratory muscle recruitment. Breathlessness has been closely linked to levels of neural respiratory drive in COPD and cystic fibrosis patients which may well explain the close link with comfort scores. However, this is the first study to suggest that  $\text{EMG}_{\text{para}}\%_{\text{max}}$  may also be a biomarker for patient comfort on non-invasive ventilation.

#### **6.4.5 Components of trigger delay**

In this study, both healthy subjects and COPD patients spent approximately 15% of their neural inspiratory time made up of delays in interacting with the ventilator, excluding the enforced trigger delays imposed by the research team. In this way, for almost a sixth of the time parasternal inspiratory muscles are activated, there is no ventilatory support being provided to the respiratory system from the ventilator. This results in an increase in the work of breathing without assistance in gas exchange. This is similar to work by Aslanain *et al*, that demonstrated in PSV mode of ventilation the effort required to trigger the ventilator represents 10–20% of the total breathing effort.(44) COPD patients had shorter inspiratory trigger delays than healthy controls in terms of overall time but their delay had an increased impact on the patients due to a shorter neural inspiratory time.

##### *Healthy subjects*

The inspiratory trigger delay in healthy subjects was driven predominantly by an increase in the ventilator trigger sensing delay, accounting for 7% of the neural inspiratory time. (Table 36). The NIPPY3+ employs a flow inspiratory trigger which detects inspiratory effort when the inspiratory flow rate exceeds a level set by the inspiratory trigger.(196) The individual flow rates for different trigger settings are not in the public domain.

Examining the healthy subjects' interaction with the ventilator in more detail we were able to demonstrate that measured leak from the mask was similar in COPD patients and healthy controls, excluding this as a significant cause of the trigger sensing delay observed. However, inspiratory flow rates on NIV were much slower in healthy subjects (Table 37) hence crossing the threshold to trigger the ventilator may have been more challenging, increasing the inspiratory triggering delay at this stage.

Inspiratory flow rates in healthy subjects, did not significantly change between 10ms and 1000ms trigger delay settings (Figure 76).

Intrinsic patient delays were as expected shorter in healthy subjects than in COPD patients due to improved pulmonary mechanics and accounted for 4% of the neural inspiratory time.

Ventilator mechanical delays were longer in healthy subjects in terms of time than the COPD patients. Excluding any interference from dynamic leak, this suggests that there is some variability in the time to deliver pressure to the patient once the ventilator senses inspiratory effort. (Table 36).

### *COPD patients*

COPD patients had longer intrinsic patient delay compared to healthy subjects. (Table 36). This is explained by the complex pulmonary mechanics observed in COPD patients. Pulmonary hyperinflation results from gas trapping in the small airways due to the obstructive airways disease in COPD, which consequently leads to flattening of diaphragm and mechanical disadvantage of the respiratory muscles.(194, 200) For inspiratory flow to occur and trigger the ventilator, the pressure at the alveolar must be lower than the pressure at the mouth. Mechanically disadvantaged inspiratory muscles leads to a delay in those muscles achieving the change in volume in the thorax required by muscle contraction to generate flow at the mouth. In addition, COPD patients also have a threshold load of intrinsic positive end expiratory pressure place upon them which must be overcome, leading to yet more delays.(194) Consequently, the respiratory muscle pump must work much harder and often contract for longer prior to generating a negative alveolar pressure and facilitating the start of inspiratory flow.(8, 57)

These findings also suggests that our focus as physicians, should be in correctly off-setting intrinsic positive end expiratory pressure (PEEPi) with appropriate levels of EPAP and using pharmacotherapeutics such as bronchodilators to optimise obstructive airways disease in COPD patients. Thereby reducing, the mechanisms contributing to intrinsic patient delays. Alternative strategies are to avoid 'over-assistance' with high levels of pressure support which can increase tidal volumes, dynamic hyperinflation and elevate intrinsic PEEP levels(13). A balance of all these factors when setting up NIV is hard to achieve and demonstrates the role of non-invasively

monitoring NRD which can provide us with a unique visual feedback of the balance we are achieving.

Lastly, when considering the interaction with the patient and the inspiratory trigger it is important to ensure that the optimal triggering mechanism is employed. Conventional non-invasive ventilators now use flow-based inspiratory triggers following work that suggested it shortened time delays compared to earlier pressure-based inspiratory triggers.(201) However, further studies have shown that replacing pressure-based triggers with flow-based triggers did not reduce wasted patient efforts.(58) Studies have recently shown that analysing interruptions in flow signals 'the shape-signal' trigger method resulted in less wasted efforts by the patient than flow-based triggering systems.(202) Although the cost of this heightened inspiratory trigger sensitivity, was more auto-triggered breaths.(202) Neurally based triggers using electromyography may be a real alternative to the traditional triggers and have shown to substantially reduce inspiratory triggering asynchrony during non-invasive ventilation.(141)

#### *Patient ventilator Interaction during trigger delay*

Healthy subjects demonstrated longer overall neural inspiratory times and slower inspiratory flow rates than COPD patients on non-invasive ventilation. In keeping with this, respiratory rates on NIV were also slower in healthy subjects.

Inspiratory flow was generated at the mouth by both COPD patients and healthy controls for approximately 80% of the total neural inspiratory time. This suggests however, that for 20% of parasternal muscle activity no detectable inspiratory flow occurred indicating significant inefficiencies in both subject groups. Inspiratory flow rates generated by COPD patients also decreased with increasing inspiratory trigger delays. This was driven predominantly by the increase in inspiratory time rather than any limitation of the inspiratory volume. (Figure 76). However, examining the coefficient of variation in tidal volume between COPD patients and healthy controls suggest that the tidal volume is related fixed in COPD patients whereas healthy subjects have a substantially increased capacity to vary their tidal volume.

The reduction in flow rates at increased trigger delays in COPD patients acts as a double disadvantage. These patients already have a substantial intrinsic delay and a lower flow rate will

increase the trigger sensing delay. Inspiratory triggering will therefore become more difficult at a point when the external enforced trigger delay is longest.

Neural-ventilator efficiency has been defined as the tidal volume generated per microvolt of electrical activity detected from the respiratory muscles.(203) It equates to the efficiency of the respiratory system and the ability of a subject to convert neuromuscular activity into tidal volume.(204) Neural-ventilator efficiency on non-invasive ventilation was significantly greater in healthy patients. This was to be expected due to the many threshold loads placed upon the COPD patient in relation to airways obstruction and positive end expiratory pressure described above that were not overcome by non-invasive ventilation in the presence of inspiratory trigger delay.

No difference in unintentional leak at the mask measured at the end of expiration was demonstrated between healthy subjects and COPD patients.

#### **6.4.6 Applicability of measuring sEMGpara%max in healthy subjects**

This study is similar to the study findings in Chapter 3, and demonstrates that measuring sEMGpara may not be achievable in all healthy subjects. Clearly using non-invasive ventilation in healthy subjects that do not require ventilatory assistance is an unnatural state. The sEMGpara signal therefore appears to be most useful when elevated in subjects with an impairment in load capacity balance. Unloading a respiratory system that is not stretched is likely to reduce parasternal activity to an unreportable signal below noise levels. Being unable to define the sEMGpara ranges for the normal population may limit the applicability of this as an assessment of lung function for the future. It is clear that we must define the upper limits of a 'normal sEMGpara signal' as it is an elevated signal that is most suggestive of a deleterious outcome. The main utility of sEMGpara%max is likely to be in longitudinal monitoring of an individual.

#### **6.4.7 Clinical significance of the findings**

COPD patients were most comfortable at the shortest inspiratory trigger delay of 10ms. A reduction in comfort scores was observed at longer trigger delays in COPD patients with maximal discomfort detected at 1000ms trigger delay. Healthy subjects tolerated inspiratory trigger delay

better than COPD patients and were most comfortable at trigger delays of 120-150ms. Similarly to COPD patients, maximal discomfort was observed in healthy subjects at an inspiratory trigger delay of 1000ms. Every effort should therefore be made to minimise inspiratory trigger delays in COPD patients to maximise patient comfort whilst on NIV.

Patient comfort on NIV in this study was negatively correlated with increasing  $sEMG_{para\%max}$ . This suggests that  $sEMG_{para\%max}$  could be used as a useful non-invasive marker in awake patients on NIV to monitor both respiratory muscle unloading and patient comfort.

COPD patients in this study did not achieve respiratory muscle unloading compared to self – ventilation in the presence of inspiratory trigger delays. Physicians should therefore focus on minimising inspiratory trigger delays to reduce the work of breathing for COPD patient on NIV.

The largest component of inspiratory trigger delay in COPD patients related to intrinsic subject delay accounting for 7 (6-9)% of neural inspiratory time. All those facilitating the setup of NIV in COPD patients must therefore take time to ensure that obstructive airways disease and EPAP levels and bronchodilator therapy are optimised first to enable good patient ventilator interaction.

## **6.5 Conclusion**

In this study, parasternal muscle activity did not increase with increasing inspiratory trigger delay in either COPD patients or healthy subjects. This finding was however limited by the small number of participants with analysable  $sEMG_{para\%max}$ . Parasternal muscle unloading was not achieved in patients with COPD on NIV in the presence of trigger delay. Consistent parasternal muscle loading occurred at trigger delays above 450ms in healthy subjects.

Patient comfort was lower with increasing trigger delays in both healthy subjects and COPD patients. Maximal comfort was achieved at the shortest trigger delay (10ms) in COPD patients but at longer trigger delays in healthy subjects (120ms and 150ms).

Finally, patient comfort negatively correlated with respiratory muscle loading in both healthy subjects and COPD patients.  $sEMG_{para\%max}$  may conceivably be used as a non-invasive marker of patient comfort on NIV.

## **Chapter 7 Conclusion**

### **7.1 Utility of sEMG<sub>para</sub>%<sub>max</sub> measurements**

#### **7.1.1 sEMG<sub>para</sub>%<sub>max</sub> as a marker of NRD in patients and healthy subjects**

sEMG<sub>para</sub>%<sub>max</sub> as a marker of neural respiratory drive is a useful non-invasive tool to monitor patients with respiratory failure and was reliably obtainable overnight in this context. The signal is low in healthy subjects due to the reduced loading of the respiratory system and is less reliable. We would not recommend using sEMG<sub>para</sub>%<sub>max</sub> in healthy subjects for monitoring neural respiratory drive in lateral postures which may occur in sleep overnight or if unloading the respiratory muscle pump with interventions such as non-invasive ventilation.

#### **7.1.2 sEMG<sub>para</sub>%<sub>max</sub> as a marker of patient comfort**

sEMG<sub>para</sub>%<sub>max</sub> has previously been related to markers of breathlessness as measured on Borg scale.(191, 205) We demonstrated that during wake the levels of sEMG<sub>para</sub>%<sub>max</sub> were also correlated with patient perception of comfort on non-invasive ventilation. sEMG<sub>para</sub>%<sub>max</sub> could be used to monitor patient comfort and optimise respiratory muscle unloading overnight on non-invasive ventilation.

#### **7.1.3 sEMG<sub>para</sub>%<sub>max</sub> as a tool to measure respiratory muscle unloading during HMV**

Both HMV set up techniques achieved a significant unloading of the respiratory muscles on the first night of NIV compared to self-ventilation. A median 5% reduction in second intercostal parasternal muscle activity was achieved in the physiological led set up of HMV compared to a 2% reduction in the physician led control. This suggests that using the parasternal signal to set up NIV may lead to faster unloading of the respiratory muscles and improved comfort associated with lower levels of NRD. Enhanced respiratory muscle unloading was preserved in the physiological led set up of HMV (9%) compared to the physician led control (6%) following 3 months of HMV therapy. Monitoring sEMG<sub>para</sub>%<sub>max</sub> provides a visual guide to the medical professional initiating ventilation to set levels of pressure support that is otherwise difficult to quantify. sEMG<sub>para</sub>%<sub>max</sub> could therefore be a useful tool to guide optimal NIV set up and may enhance respiratory muscle unloading.

#### **7.1.4 sEMGpara%max to guide the set-up of HMV**

The number of ventilator parameter manipulations required by nursing staff and physicians prior to initial discharge was greater in the physician led HMV set up group than the physiological led set up. In addition, hospital length of stay was 1 day less in the physiological set up of HMV. This may have important cost savings in optimising the set-up of HMV quickly by using a visual feedback to manipulations in settings. Reducing patient hospital bed days to improve patient access to services is an ever increasing challenge for the NHS. Reducing the burden on overnight staff to manipulate ventilator settings may be an advantage to liberate these staff to perform other tasks or to facilitate set ups in an outpatient settings where HMV expertise may not be available.

#### **7.1.5 sEMGpara%max as a marker of patient- ventilator asynchrony**

We found sEMGpara to be a useful marker of patients' inspiratory effort that can be used to identify respiration that becomes asynchronous with a mechanical ventilator. Using this technique we could non-invasively identify 7 separate types of patient ventilator asynchrony (PVA). We were able to demonstrate that the prevalence of PVA is high affecting a quarter of all breaths when studied during a whole night of non-invasive ventilation. We observed that identifying the different types of PVA was reproducible using 2 independent skilled observers. The most common type of PVA were ineffective efforts that was most concordant. Due to the time consuming nature of visual inspection of each trace this reliability could be automated to provide a real-time download of patient ventilator interaction. It was not possible to eliminate PVA overnight following accurate identification of PVA using fixed pressure settings.

## **7.2 Patient-ventilator asynchrony what have we learnt**

### **7.2.1 Prevalence of PVA**

Patient awareness of PVA was high with 61% of 110 patients surveyed aware of difficulties in synchronising with their ventilator. Patients were most able to describe difficulties with ineffective efforts (43%) followed by autotriggering events (40%). Cycling asynchrony were less common.

Overall, patient reported PVA was less frequent than the data obtained from examination of patient-ventilator interaction during overnight sleep studies. These data demonstrated that patients were unable to recall the type of PVA that had occurred overnight when questioned the

following morning. PVA may therefore not be accurately reported by patients suggesting if patient-ventilator interaction difficulties are suspected they should be formally examined prior to changes in ventilator settings being made in an outpatient review.

PVA was observed in all patients during overnight assessments. PVA levels were high affecting a quarter of all breaths overall. As with the patient reported survey, ineffective efforts remained the dominant PVA observed affecting 10% of all breaths. These levels exceed those previously described during non-invasive ventilation and are likely to represent the prolonged observation time.(76, 89) No significant improvement was observed in PVA with time spent on NIV at 3 months. This suggests that PVA levels remain high and are not related to acclimatisation to ventilation. In support of this a study by Atkeson *et al.* did not find pressure support levels or the duration of NIV use to be predictive of the severity of PVA in ALS patients using a multiple regression analysis.(206) Recently, Virjsen *et al.* also identified similar proportions of PVA at both discharge and 1 month post the set-up of HMV in the same patient group.(207)

The current PVA index which is widely used to describe the severity of PVA may not be useful in patients receiving non-invasive ventilation as the proportions of PVA are high.(77) A new index is required to standardise the reporting of PVA between studies so that the frequency of events can be compared.

### **7.2.2 PVA in different disease groups**

In this thesis, no difference was observed in the total amounts of asynchrony between the patient disease groups on either the first night of HMV set-up or 3 months post HMV therapy. In support of this finding Carlucci *et al.*, have also recently reported no difference in PVA between patients with restrictive or obstructive lung disease.(146) In addition, PVA did not correlated with markers of pulmonary mechanics such as the pressure-time product of the diaphragm, tidal volume, pulmonary resistance or dynamic compliance.(146) This may suggest that in 'real-life' PVA is mainly related to external factors such as leak at the interface rather than the patient disease process itself.

### **7.2.3 Controlling PVA with fixed bi-level ventilation settings**

Overall we were not able to significantly improve on PVA in the intervention arm of our pilot randomised control trial (RCT) compared to the physician led control. However, half the number of ineffective efforts were seen on the first night of HMV in the physiological led set-up of HMV

compared to the physician led set-up arm, although this did not reach statistical significance. A clinically significant reduction is very difficult to quantify but this would be below the threshold of severe asynchrony affecting 10% breaths set by Thille et al.(77) No significant difference in the levels of any PVA was observed at 3 months post therapy. Although, it would be ambitious to expect that changes to a ventilator made 3 months earlier would result in a persistent reduction in PVA levels.

PVA is very difficult to control due to the dynamic interplay between patient and the ventilator. In terms of pulmonary mechanics breath by breath variability occurs in lung recruitment, increasing tidal volumes which may conceivably lead to dynamic hyperinflation. Ventilation is currently delivered in the main by fixed pressure settings which do not adapt whereas, pressure support requirements may decrease with effective ventilation within hours; by offsetting intrinsic PEEP, facilitating lung emptying and improving the pressure volume relationship of the lung. This may result in a relative over assistance from pressure support with time on ventilation and may explain some success of newer modes of adaptive ventilation such as average volume assured pressure support (AVAPS), average volume assured pressure support with auto EPAP (AVAPS-AE) and intelligent volume-assured pressure assist (iVAPS). All modes maintain a target tidal volume with variable pressure support as much as is required to achieve it and the AE addition maintains a patient upper airway with a variable EPAP. The iVAPS mode also adjusts the back-up rate to facilitate the maximum number of patient triggered breaths. In the main studies comparing these novel modes of ventilation have demonstrated equivalence with conventional pressure support modes of ventilation in both control of nocturnal gas exchange and sleep disruption.(156, 208, 209) Of interest in a study of 18 patients Kelly et al, described an improved adherence to treatment with iVAPS mode and a patient preference for this mode of ventilation.(210) It is unclear as if this was related to lower pressure support levels used in the intervention arm or if this may relate to enhanced patient ventilator interaction. A confounding factor was also that the trial design did not blind participants to the treatment received. To date, no studies of PVA in these auto-titrating modes of ventilation have been conducted to assess if these can suppress current levels and improve patient outcomes. Neurally adjust ventilator assist (NAVA) mode of ventilation has been shown to consistently reduce PVAs in both an invasive and non-invasive setting. (138, 141, 211) Despite this, no significant impact on patient outcomes has yet been reported. In fact, as with the auto-titrating ventilatory modes, NAVA has demonstrated

equivalence to pressure support ventilation, in terms of both gas exchange and patient comfort. (138, 141) Furthermore, another study by Vrijsen *et al.* also identified high proportions of PVA despite meticulous titration of NIV in ALS patients over 3 nights using a fixed bilevel ventilator Trilogy 100 (Philips, Murrysville, PA, USA).(207)

Leak at the interface plays a large role particularly in disrupting the inspiratory triggering of the ventilator which depends on stability of the interface to detect a rate of change of inspiratory flow.(176) Leak may vary with different types of interface with different seal integrity, different postures adopted by the patient overnight, relative changes in tone of the chin muscles with different stages of sleep and be extremely difficult to achieve in those patients with bulbar weakness.

Changes in NRD have been observed between the different sleep stages and wake. Recently Xu *et al.* demonstrated that NRD to the diaphragm fell by 26% in non-REM sleep and 39% in REM-sleep compared to wakefulness in COPD patients overnight.(212) These complex changes in NRD affect respiratory muscle recruitment and thereby the rate of change of flow achieved at the mask which is required to trigger ventilatory support. Trigger sensitivities are fixed in standard bilevel ventilators and so there is currently no adaption to compensate for changes in pulmonary mechanics between lighter stages of sleep, deep sleep and wake. This again makes achieving perfect patient-ventilator synchronisation a challenge.

#### **7.2.4 PVA and Adherence to HMV**

In this study we did not find any association between the amount of PVA and adherence to HMV at 6 weeks or 3 months. Adherence to HMV is affected by multiple factors; in particular, frequent issues are raised surrounding the mask type, mask fit and leak especially into the eyes, claustrophobia and the overall comfort or tolerability of the interface. Other barriers may include mouth dryness, too much or too little humidification of the circuit, nasal congestion or skin reactions to the mask.(213) In addition to physical barriers, patient motivation, lifestyle factors, symptom burden, perceived benefit of treatment, patient understanding of their underlying disease process and need for treatment all contribute to patient adherence.(214) Furthermore, the RCT reported in this thesis has demonstrated that patients were unaware of levels of PVA or the types of PVA occurring during sleep suggesting that this would therefore not have a negative impact on their experience of NIV. (Section 4.3.9).

### **7.2.5 PVA and Gas Exchange**

Despite higher proportions of asynchrony observed in our cohort, there was no demonstrable effect on overnight gas exchange. This is in contrast to previous data suggesting that ineffective efforts are associated with overnight oxygen desaturation (76). This may, in part, be explained by the ventilator back up rate in the current study. The study by Fanfulla *et al.*,(76) was performed in patients already established on HMV and the study used low-level pressure support and rather unusually for patients with NMD there was no back-up rate applied. This would not be the current clinical approach, based on the evidence, which supports the use of a mandatory back up rate in NMD patients (215), ORRF patients (156, 216) and COPD (54). These data have demonstrated that optimal set up of the inspiratory positive airway pressure, the expiratory positive airway pressure and the back-up rate is more important, in terms of control of gas exchange, than PVA.

### **7.2.6 PVA and respiratory muscle loading**

No association was observed between respiratory muscle loading and patient ventilator asynchrony during the first night of HMV therapy or 3 months post HMV therapy. Previous work has identified that PVAs such as ineffective efforts are associated with an increased work of breathing measured by the PTPdi.(8, 88, 217) The lack of association between PVA (particularly IE) and work of breathing was surprising and may relate to our method of analysis. We measured respiratory muscle loading as the peak RMS of the sEMGpara signal and did not consider the length of time of overall muscle contraction. It may be that on HMV with expertise in optimising pressure support levels as used in this study that the peak muscle activity levels are suppressed but the total length of contraction is significant. Measuring the area under the curve once ECG artefact is removed from the signal may be a better method of evaluating this fully. We are currently working with biomedical engineers in collaboration with Philips research to identify a technique in which to achieve this.

### **7.2.7 PVA and Patient Quality of Life Measures**

Over 3 months of HMV therapy significant improvements were seen in patient HRQL measures using the SRI sum score, the RAND-36, the HAD score and the ESS. These improvements were observed as early as 6 weeks post initiation of treatment and this benefit was sustained at 3 months. This is in agreement with previous work demonstrating that HMV improves HRQL measures in patients with COPD, obesity, NMD and CWD.(40, 51, 67, 133, 163)

No differences were observed in the HRQL outcome measures using the SRI, SGRQ, RAND-36, FSS, ESS and HAD questionnaires between the different disease groups following 3 months of HMV.

No correlation was observed with changes in HRQL measures using total SRI scores, RAND-36, HAD, ESS, FSS and changes in PVA levels. A weak association was observed with the changes in SGRQ scores and levels of PVA. A correlation was also observed in changes of anxiety domain of the SRI questionnaire and the amount of PVA. This may suggest that patients who are more anxious are less likely to synchronise well with NIV. However, the effect of anxiety was not consistent when examining the anxiety component of the HAD. The challenge is that using anxiolytic medication in an effort to demonstrate this association also suppresses NRD which may directly affect PVA. It would therefore be very difficult to unpick if it is the change in anxiety itself leading to changes in the frequency of PVA.

PVA therefore may contribute to patient anxiety on HMV and some components of patient perception of HRQL although this was not a consistent finding across most common used HRQL questionnaires.

#### **7.2.8 PVA and Sleep Efficiency**

The amount of PVA was not heightened in any sleep stage at the initiation of NIV but at 3 months of treatment PVA was more frequently observed in lighter stages 1&2 of sleep than deep stage 3 sleep. PVA was not suppressed in REM sleep as previously described.(75, 176) No correlation was observed between PVA during sleep and the percentage of sleep time spent in stage 3 or REM sleep at initiation or 3 months of HMV therapy.

PVA was observed to precede approximately 50% of arousals both at the initiation of HMV and 3 months of treatment with no decrease in events following acclimatisation to NIV. The prevalence of PVA is so high affecting a quarter of breaths that is difficult to be clear if it is the PVA itself that is responsible. Indeed less than 10% of all PVA preceded an arousal suggesting that the majority of events are definitely not responsible for sleep disruption. In accordance, with data recently published by Vrijisen *et al.* in patients with ALS we found ineffective efforts to precede most arousals which of course is the most prevalent PVA.(207) Arousals were far more likely to occur in the lighter stages of sleep with the fewest arousals occurring in REM sleep despite similar amounts of PVA. Furthermore, PVA during sleep was not correlated to arousal levels overnight.

No relationship was observed between the total amounts of PVA or the proportion of PVA occurring during sleep and overall sleep efficiency, WASO or total sleep time at either initiation of HMV or 3 months post treatment. No relationship was observed between the PVA during wake and sleep latency at initiation of HMV. However, a relationship was demonstrated between the PVA levels occurring during wake and the sleep latency at 3 months. On the first night of HMV, we could imagine that multiple factors are affecting sleep latency with patients adapting to a new mask and the experience of overnight ventilatory pressures. Once patients are established on HMV at 3 months the impact of these external factors may have diminished and one could expect that if the patient is not synchronising well on the ventilator when awake they may not be able to relax into a physiological state required for sleep.

### **7.3 Inspiratory trigger delay**

Respiratory muscle activity as measured by sEMG $\dot{V}_{Tmax}$  was not effectively unloaded in COPD patients whilst on non-invasive ventilation with trigger delay. Indeed sEMG $\dot{V}_{Tmax}$  activity almost doubled from 18% to 33% when increasing the inspiratory delay between 10 and 1000ms. Healthy subjects as expected were able to cope with inspiratory trigger delay better and only increased NRD in the context of applied pressure support when the inspiratory trigger delays were more than 450ms.

COPD patients were most comfortable at the shortest inspiratory trigger delay setting of 10ms and as expected most uncomfortable at the longest trigger delay setting of 1000ms. Once the inspiratory trigger delay setting was longer than 150ms, comfort scores declined with increasing trigger delay settings suggesting that in COPD patients trigger delays should be kept below this level. Healthy subjects tolerated trigger delay more easily and achieve maximum comfort at 120 and 150ms delays. This may be related to the increased reserve of the respiratory system and as pressure support was not required to alleviate symptoms a gentler response from the ventilator was preferred.

Both healthy and COPD patients spent approximately 15% of their inspiratory time without ventilatory support made up of delays in triggering the ventilator. Healthy subjects demonstrated a reduced rate of change of flow and a slower breathing rate than COPD patients. They therefore exhibited an increased ventilator sensing trigger delay compared to COPD patients (i.e. the ventilator took longer to detect the rate of change of flow at the mouth). COPD patients had longer

intrinsic patient delay compared to healthy subjects (i.e. the patient took longer to generate a rate of change of flow at the mouth). This is best explained by considering the well described 'threshold load' placed on patients with COPD which results in a delay between the onset of respiratory muscle contraction and flow at the mouth. The current ventilators are triggered by a change in the rate of flow detected at the mouth and resulting in a delay in their response. Future modes of triggering the ventilator from the parasternal signal may improve upon these delays and reduce the overall work of breathing in this patient group. In the interim, we should continue to look at ways of reducing the 'threshold load' with adequate bronchodilators and appropriate levels of EPAP to open the airways and facilitate lung emptying.

## **7.4 Conclusion**

Overall, the data presented in this thesis confirmed that the proportions of PVA are high affecting all patients on non-invasive ventilation for approximately a quarter of all breaths. We were unable to demonstrate a significant impact of PVA on patient outcomes such as adherence to home mechanical ventilation, gas exchange, patient quality of life measures or sleep quality from these studies. This would suggest that controlling for PVA during sleep may not confer as much benefit as previously thought particularly in a non-invasive ventilatory setting. Clinicians focus should remain on achieving improved patient-ventilator synchrony during wake to facilitate sleep onset but concentrate on achieving improvements in gas exchange particularly reductions in arterial carbon dioxide levels and off-loading the respiratory muscles through appropriate pressure support levels and back-up rate where required.

Measuring sEMGpara during sleep may be a useful tool to guide the optimal levels of pressure support for an individual patient. It is a helpful marker to monitor the interaction between the ventilator and the patient and reducing levels of NRD may improve patient comfort on non-invasive ventilation. Furthermore, using sEMGpara to facilitate the set-up of HMV may be a cost-effective way to achieve titration pressures in an outpatient setting rather than requiring a costly inpatient overnight stay.

## 7.5 Future work

Future work should focus on using the sEMGpara for respiratory muscle unloading to optimise ventilator pressure support settings in non-expert centres to see if the parasternal signal is easily transferrable for general use. A randomised control trial would be useful to examine the utility of using the sEMGpara signal to set-up HMV as an outpatient compared to an inpatient initiation. The primary outcome could examine cost-effectiveness of the set-up with secondary outcomes examining patient adherence to HMV therapy, adequacy of gas exchange and patient health related quality of life measures.

Although we have attempted a thorough assessment of PVA on patient outcomes, we were unable to examine the effect of PVA on the autonomic nervous system and if PVA has an impact on critical cardiovascular outcomes mediated through changes in heart rate variability or blood pressure.

Personally I would also like to further examine the significance of identifying NRD via sEMGpara%max in REM sleep, to establish if it is persistent finding in patients with chronic respiratory failure or diminishes with time on HMV. I would also like to consider this a predictor of improved patient outcome if NRD is preserved in the context of severe chronic lung disease.

The future of ventilation is changing rapidly often modes of therapy are available for main stream use before clinical trials have deemed them to confer much benefit. Hopefully following on from our collaboration with Philips Research and their bioelectrical engineers we will be close to removing ECG artefact from the parasternal signal. The utility of the sEMGpara signal could then be assessed as an automated measure of changes in NRD with adaptive modes of ventilator settings as a 'real-time' assessment overnight. An automated assessment of PVA would also assist the clinician in identifying if using these dynamic modes of delivering ventilation confer any additional benefit on reducing the levels of PVA

Lastly, further work should explore the potential of using the parasternal signal as a trigger for the home mechanical ventilator overnight to improve upon neuroventilatory coupling and negate the issue of leak at the interface affecting triggering of the ventilator. We would however recommend a standard flow trigger back up for periods of poor sEMGpara signal quality such as during periods of movement

## References

1. Branson RD. Patient-ventilator interaction: the last 40 years. *Respir Care*. 2011;56(1):15-24.
2. Lassen HC. A preliminary report on the 1952 epidemic of poliomyelitis in Copenhagen with special reference to the treatment of acute respiratory insufficiency. *Lancet*. 1953;1(6749):37-41.
3. Harrison GG. Mechanical Pulmonary Ventilation: Indications for Its Uses in Surgical Cases. *S Afr Med J*. 1964;38:383-6.
4. Mushin W R-BL, Thompson PW, Mapleson WW, editor. Automatic ventilation of the lungs. 3rd ed: Oxford Blackwell Scientific; 1980.
5. Branson RD, Chatburn RL. Technical description and classification of modes of ventilator operation. *Respir Care*. 1992;37(9):1026-44.
6. Chatburn RL. Classification of mechanical ventilators. *Respir Care*. 1992;37(9):1009-25.
7. Stell IM, Paul G, Lee KC, Ponte J, Moxham J. Noninvasive ventilator triggering in chronic obstructive pulmonary disease. A test lung comparison. *Am J Respir Crit Care Med*. 2001;164(11):2092-7.
8. Leung P, Jubran A, Tobin MJ. Comparison of assisted ventilator modes on triggering, patient effort, and dyspnea. *American Journal of Respiratory and Critical Care Medicine*. 1997;155(6):1940-8.
9. Gibney RT, Wilson RS, Pontoppidan H. Comparison of work of breathing on high gas flow and demand valve continuous positive airway pressure systems. *Chest*. 1982;82(6):692-5.
10. Christopher KL, Neff TA, Bowman JL, Eberle DJ, Irvin CG, Good JT, Jr. Demand and continuous flow intermittent mandatory ventilation systems. *Chest*. 1985;87(5):625-30.
11. West J. *Respiratory Physiology The Essentials*. 7th ed: Lippincott, Williams and Wilkins; 2004. 208 p.
12. Laghi F, Tobin MJ. Disorders of the respiratory muscles. *Am J Respir Crit Care Med*. 2003;168(1):10-48.
13. Jolliet P, Tassaux D. Clinical review: patient-ventilator interaction in chronic obstructive pulmonary disease. *Crit Care*. 2006;10(6):236.
14. Hart N. *Respiratory Failure. Medicine The continuously updated review of clinical medicine*. 2008; 36 (5):4.
15. Tobin MJ, Jubran A, Laghi F. Patient-ventilator interaction. *Am J Respir Crit Care Med*. 2001;163(5):1059-63.
16. Nava S, Ceriana P. Patient-ventilator interaction during noninvasive positive pressure ventilation. *Respir Care Clin N Am*. 2005;11(2):281-93.
17. Laghi F, Karamchandani K, Tobin MJ. Influence of ventilator settings in determining respiratory frequency during mechanical ventilation. *Am J Respir Crit Care Med*. 1999;160(5 Pt 1):1766-70.
18. Vitacca M, Bianchi L, Zanotti E, Vianello A, Barbano L, Porta R, et al. Assessment of physiologic variables and subjective comfort under different levels of pressure support ventilation. *Chest*. 2004;126(3):851-9.
19. Ambrosino N, Carpenè N, Gherardi M. Chronic respiratory care for neuromuscular diseases in adults. *Eur Respir J*. 2009;34(2):444-51.
20. Steier J, Jolley CJ, Seymour J, Kaul S, Luo YM, Rafferty GF, et al. Sleep-disordered breathing in unilateral diaphragm paralysis or severe weakness. *Eur Respir J*. 2008;32(6):1479-87.
21. Polkey MI, Lyall RA, Moxham J, Leigh PN. Respiratory aspects of neurological disease. *Journal of Neurology, Neurosurgery & Psychiatry*. 1999;66(1):5-15.
22. Brusasco V, Crapo R, Viegi G. Coming together: the ATS/ERS consensus on clinical pulmonary function testing. *Eur Respir J*. 2005;26(1):1-2.
23. Beck J, Gottfried SB, Navalesi P, Skrobik Y, Comtois N, Rossini M, et al. Electrical activity of the diaphragm during pressure support ventilation in acute respiratory failure. *Am J Respir Crit Care Med*. 2001;164(3):419-24.
24. ATS/ERS Statement on Respiratory Muscle Testing. *Am J Respir Crit Care Med*. 2002;166(4):518-624.
25. Allen SM, Hunt B, Green M. Fall in vital capacity with posture. *Br J Dis Chest*. 1985;79(3):267-71.

26. Polkey MI, Green M, Moxham J. Measurement of respiratory muscle strength. *Thorax*. 1995;50(11):1131-5.
27. Uldry C, Fitting JW. Maximal values of sniff nasal inspiratory pressure in healthy subjects. *Thorax*. 1995;50(4):371-5.
28. Hutchinson D, Whyte K. Neuromuscular disease and respiratory failure. *Pract Neurol*. 2008;8(4):229-37.
29. Chetta A, Harris ML, Lyall RA, Rafferty GF, Polkey MI, Olivieri D, et al. Whistle mouth pressure as test of expiratory muscle strength. *Eur Respir J*. 2001;17(4):688-95.
30. Luo YM, Moxham J, Polkey MI. Diaphragm electromyography using an oesophageal catheter: current concepts. *Clinical Science*. 2008;115(8):233-44.
31. Luo YM, Polkey MI, Johnson LC, Lyall RA, Harris ML, Green M, et al. Diaphragm EMG measured by cervical magnetic and electrical phrenic nerve stimulation. *Journal of Applied Physiology*. 1998;85(6):2089-99.
32. Chetta A, Rehman AK, Moxham J, Carr DH, Polkey MI. Chest radiography cannot predict diaphragm function. *Respir Med*. 2005;99(1):39-44.
33. Tsara V, Serasli E, Steiropoulos P, Tsorova A, Antoniadou M, Zisi P. Respiratory function in amyotrophic lateral sclerosis patients. The role of sleep studies. *Hippokratia*. 2010;14(1):33-6.
34. Gonzalez-Bermejo J, Perrin C, Janssens JP, Pepin JL, Mroue G, Leger P, et al. Proposal for a systematic analysis of polygraphy or polysomnography for identifying and scoring abnormal events occurring during non-invasive ventilation. *Thorax*. 2010.
35. Janssens JP, Borel JC, Pepin JL, Somno NIVG. Nocturnal monitoring of home non-invasive ventilation: the contribution of simple tools such as pulse oximetry, capnography, built-in ventilator software and autonomic markers of sleep fragmentation. *Thorax*. 2011;66(5):438-45.
36. Chandra D, Stamm JA, Taylor B, Ramos RM, Satterwhite L, Krishnan JA, et al. Outcomes of noninvasive ventilation for acute exacerbations of chronic obstructive pulmonary disease in the United States, 1998-2008. *Am J Respir Crit Care Med*. 2012;185(2):152-9.
37. Polkey MI. Neuromuscular Disease. In: Gibson GJ GD, Costabel U, Sterk P, Corrin B, editor. *Respiratory Medicine*. 2. 3rd ed: Saunders Ltd; 2002.
38. Rideau Y, Gatin G, Bach J, Gines G. Prolongation of life in Duchenne's muscular dystrophy. *Acta Neurol (Napoli)*. 1983;5(2):118-24.
39. Nickol AH, Hart N, Hopkinson NS, Moxham J, Simonds A, Polkey MI. Mechanisms of improvement of respiratory failure in patients with restrictive thoracic disease treated with non-invasive ventilation. *Thorax*. 2005;60(9):754-60.
40. Bourke SC, Tomlinson M, Williams TL, Bullock RE, Shaw PJ, Gibson GJ. Effects of non-invasive ventilation on survival and quality of life in patients with amyotrophic lateral sclerosis: a randomised controlled trial. *Lancet Neurol*. 2006;5(2):140-7.
41. Raphael JC, Chevret S, Chastang C, Bouvet F. Randomised trial of preventive nasal ventilation in Duchenne muscular dystrophy. French Multicentre Cooperative Group on Home Mechanical Ventilation Assistance in Duchenne de Boulogne Muscular Dystrophy. *Lancet*. 1994;343(8913):1600-4.
42. Polkey MI, Lyall RA, Davidson AC, Leigh PN, Moxham J. Ethical and clinical issues in the use of home non-invasive mechanical ventilation for the palliation of breathlessness in motor neurone disease. *Thorax*. 1999;54(4):367-71.
43. Buyse B, Meersseman W, Demedts M. Treatment of chronic respiratory failure in kyphoscoliosis: oxygen or ventilation? *Eur Respir J*. 2003;22(3):525-8.
44. Aslanian P, El Atrous S, Isabey D, Valente E, Corsi D, Harf A, et al. Effects of flow triggering on breathing effort during partial ventilatory support. *Am J Respir Crit Care Med*. 1998;157(1):135-43.
45. O'Donnell DE, Laveneziana P. Physiology and consequences of lung hyperinflation in COPD. *European Respiratory Review*. 2006;15(100):61-7.
46. O'Donnell DE, Laveneziana P. The clinical importance of dynamic lung hyperinflation in COPD. *COPD*. 2006;3(4):219-32.
47. Calverley PMA. Respiratory failure in chronic obstructive pulmonary disease. *European Respiratory Journal*. 2003;22(47 suppl):26s-30s.
48. Plant PK, Elliott MW. Chronic obstructive pulmonary disease • 9: Management of ventilatory failure in COPD. *Thorax*. 2003;58(6):537-42.
49. Continuous or nocturnal oxygen therapy in hypoxemic chronic obstructive lung disease: a clinical trial. Nocturnal Oxygen Therapy Trial Group. *Ann Intern Med*. 1980;93(3):391-8.
50. Casanova C, Celli BR, Tost L, Soriano E, Abreu J, Velasco V, et al. Long-term Controlled Trial of Nocturnal Nasal Positive Pressure Ventilation in Patients With Severe COPD\*. *Chest*. 2000;118(6):1582-90.

51. Clini E, Sturani C, Rossi A, Viaggi S, Corrado A, Donner CF, et al. The Italian multicentre study on noninvasive ventilation in chronic obstructive pulmonary disease patients. *European Respiratory Journal*. 2002;20(3):529-38.
52. Lin CC. Comparison between nocturnal nasal positive pressure ventilation combined with oxygen therapy and oxygen monotherapy in patients with severe COPD. *American Journal of Respiratory and Critical Care Medicine*. 1996;154(2):353-8.
53. Murphy P, Hart N. Who benefits from home mechanical ventilation? *Clin Med*. 2009;9(2):160-3.
54. Windisch W HM, Storre JH, Dreher M. High-intensity non-invasive positive pressure ventilation for stable hypercapnic COPD. *Int J Med Sci* 2009;6(2):72-6.
55. Murphy PB, Rehal S, Arbane G, Bourke S, Calverley PMA, Crook AM, et al. Effect of Home Noninvasive Ventilation With Oxygen Therapy vs Oxygen Therapy Alone on Hospital Readmission or Death After an Acute COPD Exacerbation: A Randomized Clinical Trial. *JAMA*. 2017;317(21):2177-86.
56. Nickol AH, Hart N, Hopkinson NS, Hamnegard CH, Moxham J, Simonds A, et al. Mechanisms of improvement of respiratory failure in patients with COPD treated with NIV. *Int J Chron Obstruct Pulmon Dis*. 2008;3(3):453-62.
57. Nava S, Bruschi C, Rubini F, Palo A, Iotti G, Braschi A. Respiratory response and inspiratory effort during pressure support ventilation in COPD patients. *Intensive Care Med*. 1995;21(11):871-9.
58. Chao DC, Scheinhorn DJ, Stearn-Hassenpflug M. Patient-ventilator trigger asynchrony in prolonged mechanical ventilation. *Chest*. 1997;112(6):1592-9.
59. Tassaux D, Gannier M, Battisti A, Jolliet P. Impact of expiratory trigger setting on delayed cycling and inspiratory muscle workload. *Am J Respir Crit Care Med*. 2005;172(10):1283-9.
60. Piper AJ, Grunstein RR. Obesity Hypoventilation Syndrome. *American Journal of Respiratory and Critical Care Medicine*. 2011;183(3):292-8.
61. Kelly TM, Jensen RL, Elliott CG, Crapo RO. Maximum respiratory pressures in morbidly obese subjects. *Respiration*. 1988;54(2):73-7.
62. Sampson MG, Grassino K. Neuromechanical properties in obese patients during carbon dioxide rebreathing. *Am J Med*. 1983;75(1):81-90.
63. Mokhlesi B. Obesity hypoventilation syndrome: a state-of-the-art review. *Respir Care*. 2010;55(10):1347-62; discussion 63-5.
64. Piper AJ. Obesity hypoventilation syndrome - The big and the breathless. *Sleep Med Rev*. 2011;15(2):79-89.
65. Ray CS, Sue DY, Bray G, Hansen JE, Wasserman K. Effects of obesity on respiratory function. *Am Rev Respir Dis*. 1983;128(3):501-6.
66. Steier J, Jolley CJ, Seymour J, Roughton M, Polkey MI, Moxham J. Neural respiratory drive in obesity. *Thorax*. 2009;64(8):719-25.
67. Piper AJ, Wang D, Yee BJ, Barnes DJ, Grunstein RR. Randomised trial of CPAP vs bilevel support in the treatment of obesity hypoventilation syndrome without severe nocturnal desaturation. *Thorax*. 2008;63(5):395-401.
68. Nowbar S, Burkart KM, Gonzales R, Fedorowicz A, Gozansky WS, Gaudio JC, et al. Obesity-Associated hypoventilation in hospitalized patients: prevalence, effects, and outcome. *The American Journal of Medicine*. 2004;116(1):1-7.
69. Redolfi S, Corda L, La Piana G, Spandrio S, Prometti P, Tantucci C. Long-term non-invasive ventilation increases chemosensitivity and leptin in obesity-hypoventilation syndrome. *Respir Med*. 2007;101(6):1191-5.
70. Guo YF, Sforza E, Janssens JP. Respiratory Patterns During Sleep in Obesity-Hypoventilation Patients Treated With Nocturnal Pressure Support\*A Preliminary Report. *CHEST Journal*. 2007;131(4):1090-9.
71. Weng CL, Zhao YT, Liu QH, Fu CJ, Sun F, Ma YL, et al. Meta-analysis: Noninvasive ventilation in acute cardiogenic pulmonary edema. *Ann Intern Med*. 2010;152(9):590-600.
72. Demoule A, Girou E, Richard JC, Taille S, Brochard L. Increased use of noninvasive ventilation in French intensive care units. *Intensive Care Med*. 2006;32(11):1747-55.
73. Davies M. British Thoracic Society NIV Audit 2013 (national audit period 1 February – 31 March 2013)2013 [2 p.].
74. Khatun Y MP, Davidson AC, Hart N. SEASONAL VARIATION IN INITIATION AND DISCONTINUATION OF DOMICILIARY NON-INVASIVE VENTILATION: A 12-MONTH COHORT STUDY. *Thorax (Winter meeting supplement)* 2011;6:A179.

75. Fanfulla F, Delmastro M, Berardinelli A, Lupo ND, Nava S. Effects of different ventilator settings on sleep and inspiratory effort in patients with neuromuscular disease. *Am J Respir Crit Care Med.* 2005;172(5):619-24.
76. Fanfulla F, Taurino AE, Lupo ND, Trentin R, D'Ambrosio C, Nava S. Effect of sleep on patient/ventilator asynchrony in patients undergoing chronic non-invasive mechanical ventilation. *Respir Med.* 2007;101(8):1702-7.
77. Thille AW, Rodriguez P, Cabello B, Lellouche F, Brochard L. Patient-ventilator asynchrony during assisted mechanical ventilation. *Intensive Care Med.* 2006;32(10):1515-22.
78. de Wit M, Miller KB, Green DA, Ostman HE, Gennings C, Epstein SK. Ineffective triggering predicts increased duration of mechanical ventilation. *Crit Care Med.* 2009;37(10):2740-5.
79. Ramsay M, Mandal S, Suh ES, Steier J, Douiri A, Murphy PB, et al. Parasternal electromyography to determine the relationship between patient-ventilator asynchrony and nocturnal gas exchange during home mechanical ventilation set-up. *Thorax.* 2015;70(10):946-52.
80. Carreaux G, Lyazidi A, Cordoba-Izquierdo A, Vignaux L, Jolliet P, Thille AW, et al. Patient-ventilator asynchrony during noninvasive ventilation: A bench and clinical study. *Chest.* 2012.
81. Hunter KD, Faulkner JA. Pliometric contraction-induced injury of mouse skeletal muscle: effect of initial length. *J Appl Physiol.* 1997;82(1):278-83.
82. Epstein SK. How often does patient-ventilator asynchrony occur and what are the consequences? *Respir Care.* 2011;56(1):25-38.
83. Sassooun CS, Zhu E, Caiozzo VJ. Assist-control mechanical ventilation attenuates ventilator-induced diaphragmatic dysfunction. *Am J Respir Crit Care Med.* 2004;170(6):626-32.
84. Vassilakopoulos T, Petrof BJ. Ventilator-induced diaphragmatic dysfunction. *Am J Respir Crit Care Med.* 2004;169(3):336-41.
85. Petrof BJ, Jaber S, Matecki S. Ventilator-induced diaphragmatic dysfunction. *Curr Opin Crit Care.* 2010;16(1):19-25.
86. Nava S, Bruschi C, Fracchia C, Braschi A, Rubini F. Patient-ventilator interaction and inspiratory effort during pressure support ventilation in patients with different pathologies. *Eur Respir J.* 1997;10(1):177-83.
87. Field S, Sanci S, Grassino A. Respiratory muscle oxygen consumption estimated by the diaphragm pressure-time index. *Journal of applied physiology: respiratory, environmental and exercise physiology.* 1984;57(1):44-51.
88. Thille AW, Cabello B, Galia F, Lyazidi A, Brochard L. Reduction of patient-ventilator asynchrony by reducing tidal volume during pressure-support ventilation. *Intensive Care Med.* 2008;34(8):1477-86.
89. Vignaux L, Vargas F, Roeseler J, Tassaux D, Thille AW, Kossowsky MP, et al. Patient-ventilator asynchrony during non-invasive ventilation for acute respiratory failure: a multicenter study. *Intensive Care Med.* 2009;35(5):840-6.
90. Moerer O, Beck J, Brander L, Costa R, Quintel M, Slutsky AS, et al. Subject-ventilator synchrony during neural versus pneumatically triggered non-invasive helmet ventilation. *Intensive Care Med.* 2008;34(9):1615-23.
91. Bosma K, Ferreyra G, Ambrogio C, Pasero D, Mirabella L, Braghiroli A, et al. Patient-ventilator interaction and sleep in mechanically ventilated patients: pressure support versus proportional assist ventilation. *Crit Care Med.* 2007;35(4):1048-54.
92. El-Khatib MF, Zeineldine SM, Jamaledine GW. Effect of pressure support ventilation and positive end expiratory pressure on the rapid shallow breathing index in intensive care unit patients. *Intensive Care Med.* 2008;34(3):505-10.
93. de Wit M, Pedram S, Best AM, Epstein SK. Observational study of patient-ventilator asynchrony and relationship to sedation level. *J Crit Care.* 2009;24(1):74-80.
94. Steiner MC, Barton RL, Singh SJ, Morgan MD. Bedside methods versus dual energy X-ray absorptiometry for body composition measurement in COPD. *Eur Respir J.* 2002;19(4):626-31.
95. Johns MW. A new method for measuring daytime sleepiness: the Epworth sleepiness scale. *Sleep.* 1991;14(6):540-5.
96. Krupp LB, LaRocca NG, Muir-Nash J, Steinberg AD. The fatigue severity scale. Application to patients with multiple sclerosis and systemic lupus erythematosus. *Arch Neurol.* 1989;46(10):1121-3.
97. Zigmund AS, Snaith RP. The hospital anxiety and depression scale. *Acta Psychiatr Scand.* 1983;67(6):361-70.
98. Windisch W, Freidel K, Schucher B, Baumann H, Wiebel M, Matthys H, et al. The Severe Respiratory Insufficiency (SRI) Questionnaire: a specific measure of health-related quality of life in patients receiving home mechanical ventilation. *J Clin Epidemiol.* 2003;56(8):752-9.

99. Jones PW, Quirk FH, Baveystock CM, Littlejohns P. A self-complete measure of health status for chronic airflow limitation. The St. George's Respiratory Questionnaire. *Am Rev Respir Dis.* 1992;145(6):1321-7.
100. Jones PW. Health status measurement in chronic obstructive pulmonary disease. *Thorax.* 2001;56(11):880-7.
101. Jones PW, Mahler DA, Gale R, Owen R, Kramer B. Profiling the effects of indacaterol on dyspnoea and health status in patients with COPD. *Respiratory Medicine.* 2011;105(6):892-9.
102. Jones PW, Brusselle G, Dal Negro RW, Ferrer M, Kardos P, Levy ML, et al. Health-related quality of life in patients by COPD severity within primary care in Europe. *Respiratory Medicine.* 2011;105(1):57-66.
103. Spencer S, Calverley PM, Sherwood Burge P, Jones PW, Disease ISGISiOL. Health status deterioration in patients with chronic obstructive pulmonary disease. *Am J Respir Crit Care Med.* 2001;163(1):122-8.
104. Jones PW. St. George's Respiratory Questionnaire: MCID. COPD. 2005;2(1):75-9.
105. Hays RD, Morales LS. The RAND-36 measure of health-related quality of life. *Ann Med.* 2001;33(5):350-7.
106. Wewers ME, Lowe NK. A critical review of visual analogue scales in the measurement of clinical phenomena. *Res Nurs Health.* 1990;13(4):227-36.
107. Grant S, Aitchison T, Henderson E, Christie J, Zare S, McMurray J, et al. A comparison of the reproducibility and the sensitivity to change of visual analogue scales, Borg scales, and Likert scales in normal subjects during submaximal exercise. *Chest.* 1999;116(5):1208-17.
108. Luo YM, Wu HD, Tang J, Jolley C, Steier J, Moxham J, et al. Neural respiratory drive during apnoeic events in obstructive sleep apnoea. *Eur Respir J.* 2008;31(3):650-7.
109. Luo YM, Tang J, Jolley C, Steier J, Zhong NS, Moxham J, et al. Distinguishing obstructive from central sleep apnea events: diaphragm electromyogram and esophageal pressure compared. *Chest.* 2009;135(5):1133-41.
110. Laroche CM, Mier AK, Moxham J, Green M. Diaphragm strength in patients with recent hemidiaphragm paralysis. *Thorax.* 1988;43(3):170-4.
111. Cherniack RM, Farhi LE, Armstrong BW, Proctor DF. A comparison of esophageal and intrapleural pressure in man. *J Appl Physiol.* 1955;8(2):203-11.
112. Tzelepis GE, Nasiff L, McCool FD, Hammond J. Transmission of pressure within the abdomen. *J Appl Physiol (1985).* 1996;81(3):1111-4.
113. Agostini E RH. Abdominal and thoracic pressures at different lung volumes. *Journal of Applied Physiology.* 1960;15:1087-92.
114. Xiao SC, He BT, Steier J, Moxham J, Polkey MI, Luo YM. Neural Respiratory Drive and Arousal in Patients with Obstructive Sleep Apnea Hypopnea. *Sleep.* 2015;38(6):941-9.
115. Sykes M VM, Hull C. Principles of Measurement and Monitoring in Anaesthesia and Intensive Care. 3rd ed. Oxford, United Kingdom John Wiley and Sons Ltd; 1991.
116. Mazeika G SR. Respiratory Inductance Plethysmography An Introduction2007:[1-13 pp.].
117. Iber C A-IS, Chesson AL, Quan SF. The AASM manual for the scoring of sleep and associated events: rules, terminology and technical specifications. . Westchester, IL: American Academy of Sleep Medicine, 2007.
118. Sleep-related breathing disorders in adults: recommendations for syndrome definition and measurement techniques in clinical research. The Report of an American Academy of Sleep Medicine Task Force. *Sleep.* 1999;22(5):667-89.
119. Boselli M, Parrino L, Smerieri A, Terzano MG. Effect of age on EEG arousals in normal sleep. *Sleep.* 1998;21(4):351-7.
120. Spahija J, de Marchie M, Albert M, Bellemare P, Delisle S, Beck J, et al. Patient-ventilator interaction during pressure support ventilation and neurally adjusted ventilatory assist. *Crit Care Med.* 2010;38(2):518-26.
121. Gandevia SC, Hudson AL, Gorman RB, Butler JE, De Troyer A. Spatial distribution of inspiratory drive to the parasternal intercostal muscles in humans. *J Physiol.* 2006;573(Pt 1):263-75.
122. De Troyer A, Kirkwood PA, Wilson TA. Respiratory action of the intercostal muscles. *Physiol Rev.* 2005;85(2):717-56.
123. Duiverman ML, van Eykern LA, Vennik PW, Koeter GH, Maarsingh EJ, Wijkstra PJ. Reproducibility and responsiveness of a noninvasive EMG technique of the respiratory muscles in COPD patients and in healthy subjects. *J Appl Physiol.* 2004;96(5):1723-9.
124. Murphy PB, Kumar A, Reilly C, Jolley C, Waltersbacher S, Fedele F, et al. Neural respiratory drive as a physiological biomarker to monitor change during acute exacerbations of COPD. *Thorax.* 2011;66(7):602-8.

125. Steier J, Jolley CJ, Polkey MI, Moxham J. Nocturnal asthma monitoring by chest wall electromyography. *Thorax*. 2011;66(7):609-14.
126. Maarsingh EJ, van Eykern LA, de Haan RJ, Griffioen RW, Hoekstra MO, van Aalderen WM. Airflow limitation in asthmatic children assessed with a non-invasive EMG technique. *Respir Physiol Neurobiol*. 2002;133(1-2):89-97.
127. Reilly CC, Ward K, Jolley CJ, Lunt AC, Steier J, Elston C, et al. Neural respiratory drive, pulmonary mechanics and breathlessness in patients with cystic fibrosis. *Thorax*. 2011;66(3):240-6.
128. Lecomte F, Brander L, Jalde F, Beck J, Qui H, Elie C, et al. Physiological response to increasing levels of neurally adjusted ventilatory assist (NAVA). *Respir Physiol Neurobiol*. 2009;166(2):117-24.
129. Wanke T, Lahrmann H, Formanek D, Zwick H. Effect of posture on inspiratory muscle electromyogram response to hypercapnia. *Eur J Appl Physiol Occup Physiol*. 1992;64(3):266-71.
130. Druz WS, Sharp JT. Activity of respiratory muscles in upright and recumbent humans. *J Appl Physiol*. 1981;51(6):1552-61.
131. Reilly CC, Jolley CJ, Ward K, MacBean V, Moxham J, Rafferty GF. Neural respiratory drive measured during inspiratory threshold loading and acute hypercapnia in healthy individuals. *Experimental physiology*. 2013;98(7):1190-8.
132. Jolley CJ, Luo YM, Steier J, Reilly C, Seymour J, Lunt A, et al. Neural respiratory drive in healthy subjects and in COPD. *Eur Respir J*. 2009;33(2):289-97.
133. Simonds AK, Muntoni F, Heather S, Fielding S. Impact of nasal ventilation on survival in hypercapnic Duchenne muscular dystrophy. *Thorax*. 1998;53(11):949-52.
134. Lloyd-Owen SJ, Donaldson GC, Ambrosino N, Escarabill J, Farre R, Fauroux B, et al. Patterns of home mechanical ventilation use in Europe: results from the Eurovent survey. *European Respiratory Journal*. 2005;25(6):1025-31.
135. Vitacca M, Lanini B, Nava S, Barbano L, Portal R, Clini E, et al. Inspiratory muscle workload due to dynamic intrinsic PEEP in stable COPD patients: effects of two different settings of non-invasive pressure-support ventilation. *Monaldi Arch Chest Dis*. 2004;61(2):81-5.
136. Vitacca M, Nava S, Confalonieri M, Bianchi L, Porta R, Clini E, et al. The appropriate setting of noninvasive pressure support ventilation in stable COPD patients. *Chest*. 2000;118(5):1286-93.
137. Sinderby C, Navalesi P, Beck J, Skrobik Y, Comtois N, Friberg S, et al. Neural control of mechanical ventilation in respiratory failure. *Nat Med*. 1999;5(12):1433-6.
138. Piquilloud L, Vignaux L, Bialais E, Roeseler J, Sottiaux T, Laterre PF, et al. Neurally adjusted ventilatory assist improves patient-ventilator interaction. *Intensive Care Med*. 2011;37(2):263-71.
139. Vignaux L, Grazioli S, Piquilloud L, Bochaton N, Karam O, Levy-Jamet Y, et al. Patient-ventilator asynchrony during noninvasive pressure support ventilation and neurally adjusted ventilatory assist in infants and children. *Pediatr Crit Care Med*. 2013;14(8):e357-64.
140. Fauroux B, Hart N, Luo YM, MacNeill S, Moxham J, Lofaso F, et al. Measurement of diaphragm loading during pressure support ventilation. *Intensive Care Med*. 2003;29(11):1960-6.
141. Bertrand PM, Futier E, Coisel Y, Matecki S, Jaber S, Constantin JM. Neurally adjusted ventilator assist versus pressure support ventilation for noninvasive ventilation during acute respiratory failure: a cross-over physiological study. *Chest*. 2012.
142. Hudson AL, Butler JE, Gandevia SC, De Troyer A. Interplay between the inspiratory and postural functions of the human parasternal intercostal muscles. *J Neurophysiol*. 2010;103(3):1622-9.
143. Whitelaw WA, Feroah T. Patterns of intercostal muscle activity in humans. *J Appl Physiol* (1985). 1989;67(5):2087-94.
144. De Troyer A, Legrand A, Gevenois PA, Wilson TA. Mechanical advantage of the human parasternal intercostal and triangularis sterni muscles. *J Physiol*. 1998;513 ( Pt 3):915-25.
145. Jolley CJ, Moxham J. A physiological model of patient-reported breathlessness during daily activities in COPD. *Eur Respir Rev*. 2009;18(112):66-79.
146. Carlucci A, Pisani L, Ceriana P, Malovini A, Nava S. Patient-ventilator asynchronies: may the respiratory mechanics play a role? *Crit Care*. 2013;17(2):R54.
147. Bennett JR, Dunroy HM, Corfield DR, Hart N, Simonds AK, Polkey MI, et al. Respiratory muscle activity during REM sleep in patients with diaphragm paralysis. *Neurology*. 2004;62(1):134-7.
148. Adler D, Perrig S, Takahashi H, Espa F, Rodenstein D, Pepin JL, et al. Polysomnography in stable COPD under non-invasive ventilation to reduce patient-ventilator asynchrony and morning breathlessness. *Sleep Breath*. 2012;16(4):1081-90.
149. Contal O, Vignaux L, Combescure C, Pepin JL, Jolliet P, Janssens JP. Monitoring of noninvasive ventilation by built-in software of home bilevel ventilators: a bench study. *Chest*. 2012;141(2):469-76.

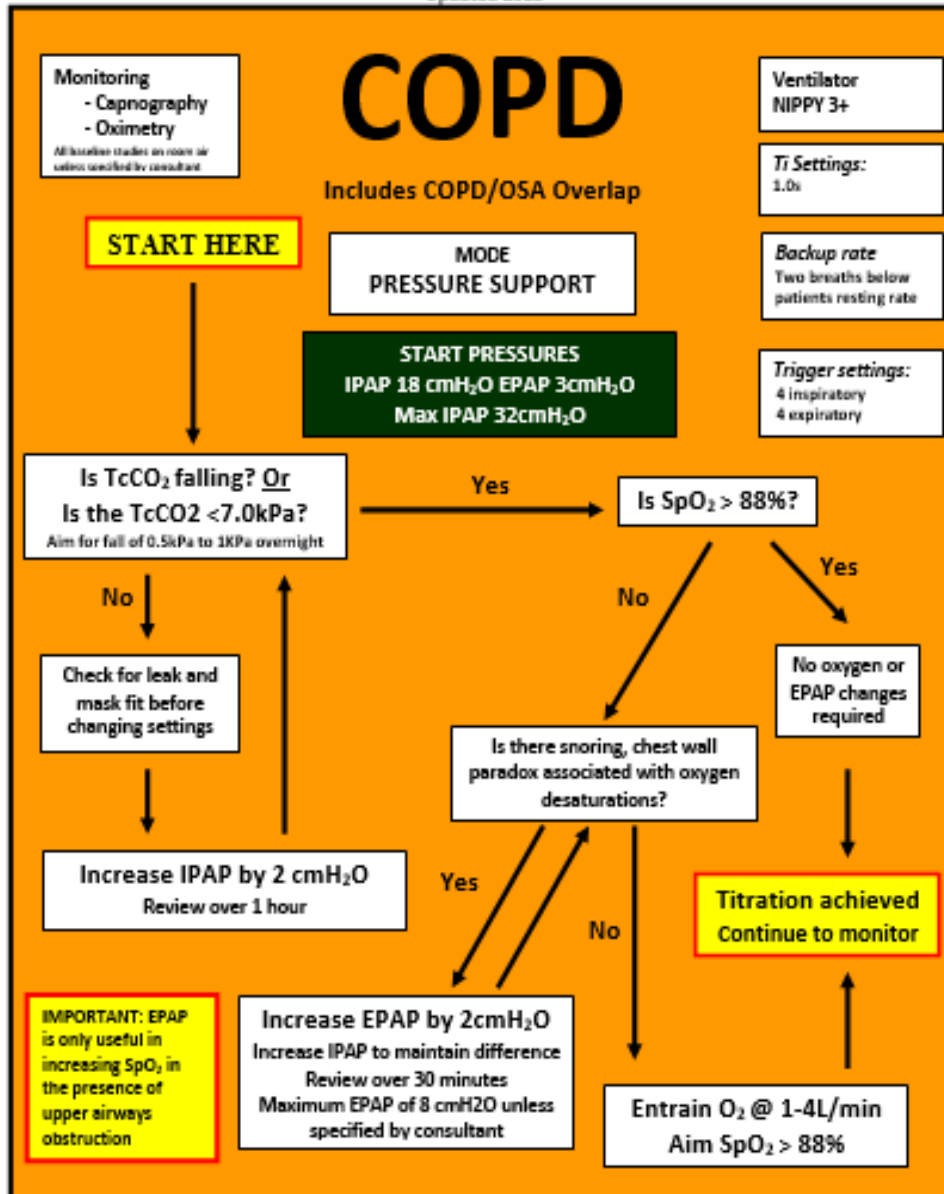
150. Storre JH, Steurer B, Kabitz HJ, Dreher M, Windisch W. Transcutaneous PCO<sub>2</sub> monitoring during initiation of noninvasive ventilation. *Chest*. 2007;132(6):1810-6.
151. Storre JH, Magnet FS, Dreher M, Windisch W. Transcutaneous monitoring as a replacement for arterial PCO<sub>2</sub> monitoring during nocturnal non-invasive ventilation. *Respir Med*. 2011;105(1):143-50.
152. Thurnheer R, Xie X, Bloch KE. Accuracy of nasal cannula pressure recordings for assessment of ventilation during sleep. *Am J Respir Crit Care Med*. 2001;164(10 Pt 1):1914-9.
153. Colombo D, Cammarota G, Alemani M, Carezzo L, Barra FL, Vaschetto R, et al. Efficacy of ventilator waveforms observation in detecting patient-ventilator asynchrony. *Crit Care Med*. 2011;39(11):2452-7.
154. Vignaux L, Tassaux D, Carreaux G, Roeseler J, Piquilloud L, Brochard L, et al. Performance of noninvasive ventilation algorithms on ICU ventilators during pressure support: a clinical study. *Intensive Care Med*. 2010;36(12):2053-9.
155. Mehta S, McCool FD, Hill NS. Leak compensation in positive pressure ventilators: a lung model study. *Eur Respir J*. 2001;17(2):259-67.
156. Murphy PB, Davidson C, Hind MD, Simonds A, Williams AJ, Hopkinson NS, et al. Volume targeted versus pressure support non-invasive ventilation in patients with super obesity and chronic respiratory failure: a randomised controlled trial. *Thorax*. 2012;67(8):727-34.
157. Navalesi P, Fanfulla F, Frigerio P, Gregoretti C, Nava S. Physiologic evaluation of noninvasive mechanical ventilation delivered with three types of masks in patients with chronic hypercapnic respiratory failure. *Crit Care Med*. 2000;28(6):1785-90.
158. Kwok H, McCormack J, Cece R, Houtchens J, Hill NS. Controlled trial of oronasal versus nasal mask ventilation in the treatment of acute respiratory failure. *Crit Care Med*. 2003;31(2):468-73.
159. Holanda MA, Reis RC, Winkeler GF, Fortaleza SC, Lima JW, Pereira ED. Influence of total face, facial and nasal masks on short-term adverse effects during noninvasive ventilation. *J Bras Pneumol*. 2009;35(2):164-73.
160. Simonds AK, Elliott MW. Outcome of domiciliary nasal intermittent positive pressure ventilation in restrictive and obstructive disorders. *Thorax*. 1995;50(6):604-9.
161. McNicholas WT. Impact of sleep in respiratory failure. *Eur Respir J*. 1997;10(4):920-33.
162. McNicholas WT. Impact of sleep on respiratory muscle function. *Monaldi Arch Chest Dis*. 2002;57(5-6):277-80.
163. Windisch W. Quality of life in home mechanical ventilation study g. Impact of home mechanical ventilation on health-related quality of life. *Eur Respir J*. 2008;32(5):1328-36.
164. Nauffal D, Domenech R, Martinez Garcia MA, Compte L, Macian V, Perpina M. Noninvasive positive pressure home ventilation in restrictive disorders: outcome and impact on health-related quality of life. *Respir Med*. 2002;96(10):777-83.
165. Carreaux G, Mancebo J, Mercat A, Dellamonica J, Richard JC, Aguirre-Bermeo H, et al. Bedside adjustment of proportional assist ventilation to target a predefined range of respiratory effort. *Crit Care Med*. 2013;41(9):2125-32.
166. Becker HF, Piper AJ, Flynn WE, McNamara SG, Grunstein RR, Peter JH, et al. Breathing during sleep in patients with nocturnal desaturation. *Am J Respir Crit Care Med*. 1999;159(1):112-8.
167. Elliott MW. Non-invasive ventilation during sleep: time to define new tools in the systematic evaluation of the technique. *Thorax*. 2011;66(1):82-4.
168. Ragette R, Mellies U, Schwake C, Voit T, Teschler H. Patterns and predictors of sleep disordered breathing in primary myopathies. *Thorax*. 2002;57(8):724-8.
169. Punjabi NM, O'Hearn D J, Neubauer DN, Nieto FJ, Schwartz AR, Smith PL, et al. Modeling hypersomnolence in sleep-disordered breathing. A novel approach using survival analysis. *Am J Respir Crit Care Med*. 1999;159(6):1703-9.
170. Irwin M, McClintick J, Costlow C, Fortner M, White J, Gillin JC. Partial night sleep deprivation reduces natural killer and cellular immune responses in humans. *FASEB J*. 1996;10(5):643-53.
171. White DP, Douglas NJ, Pickett CK, Zwillich CW, Weil JV. Sleep deprivation and the control of ventilation. *Am Rev Respir Dis*. 1983;128(6):984-6.
172. Juan G, Calverley P, Talamo C, Schnader J, Roussos C. Effect of carbon dioxide on diaphragmatic function in human beings. *N Engl J Med*. 1984;310(14):874-9.
173. Schonhofer B, Kohler D. Effect of non-invasive mechanical ventilation on sleep and nocturnal ventilation in patients with chronic respiratory failure. *Thorax*. 2000;55(4):308-13.
174. Parthasarathy S, Tobin MJ. Effect of ventilator mode on sleep quality in critically ill patients. *Am J Respir Crit Care Med*. 2002;166(11):1423-9.

175. Bergbom-Engberg I, Haljamae H. Patient experiences during respirator treatment--reason for intermittent positive-pressure ventilation treatment and patient awareness in the intensive care unit. *Crit Care Med.* 1989;17(1):22-5.
176. Crescimanno G, Canino M, Marrone O. Asynchronies and sleep disruption in neuromuscular patients under home noninvasive ventilation. *Respir Med.* 2012;106(10):1478-85.
177. Pitson DJ, Stradling JR. Autonomic markers of arousal during sleep in patients undergoing investigation for obstructive sleep apnoea, their relationship to EEG arousals, respiratory events and subjective sleepiness. *J Sleep Res.* 1998;7(1):53-9.
178. Eckert DJ, White DP, Jordan AS, Malhotra A, Wellman A. Reply: Arousal threshold in obstructive sleep apnea. *Am J Respir Crit Care Med.* 2014;189(3):373-4.
179. Gouveris H, Selivanova O, Bausmer U, Goepel B, Mann W. First-night-effect on polysomnographic respiratory sleep parameters in patients with sleep-disordered breathing and upper airway pathology. *European archives of oto-rhino-laryngology : official journal of the European Federation of Oto-Rhino-Laryngological Societies.* 2010;267(9):1449-53.
180. Willson GN, Piper AJ, Norman M, Chaseling WG, Milross MA, Collins ER, et al. Nasal versus full face mask for noninvasive ventilation in chronic respiratory failure. *Eur Respir J.* 2004;23(4):605-9.
181. Pehrsson K, Olofson J, Larsson S, Sullivan M. Quality of life of patients treated by home mechanical ventilation due to restrictive ventilatory disorders. *Respir Med.* 1994;88(1):21-6.
182. Lyall RA, Donaldson N, Fleming T, Wood C, Newsom-Davis I, Polkey MI, et al. A prospective study of quality of life in ALS patients treated with noninvasive ventilation. *Neurology.* 2001;57(1):153-6.
183. Katzberg HD, Selegiman A, Guion L, Yuan N, Cho SC, Katz JS, et al. Effects of noninvasive ventilation on sleep outcomes in amyotrophic lateral sclerosis. *Journal of clinical sleep medicine : JCSM : official publication of the American Academy of Sleep Medicine.* 2013;9(4):345-51.
184. Meyer TJ, Pressman MR, Benditt J, McCool FD, Millman RP, Natarajan R, et al. Air leaking through the mouth during nocturnal nasal ventilation: effect on sleep quality. *Sleep.* 1997;20(7):561-9.
185. Tassaux D, Strasser S, Fonseca S, Dalmas E, Jolliet P. Comparative bench study of triggering, pressurization, and cycling between the home ventilator VPAP II and three ICU ventilators. *Intensive Care Medicine.* 2002;28(9):1254-61.
186. Thille AW, Lyazidi A, Richard JC, Galia F, Brochard L. A bench study of intensive-care-unit ventilators: new versus old and turbine-based versus compressed gas-based ventilators. *Intensive Care Med.* 2009;35(8):1368-76.
187. Richard JC, Carlucci A, Breton L, Langlais N, Jaber S, Maggiore S, et al. Bench testing of pressure support ventilation with three different generations of ventilators. *Intensive Care Medicine.* 2002;28(8):1049-57.
188. Battisti A, Tassaux D, Janssens JP, Michotte JB, Jaber S, Jolliet P. Performance characteristics of 10 home mechanical ventilators in pressure-support mode: a comparative bench study. *Chest.* 2005;127(5):1784-92.
189. Vignaux L, Tassaux D, Jolliet P. Performance of noninvasive ventilation modes on ICU ventilators during pressure support: a bench model study. *Intensive Care Med.* 2007;33(8):1444-51.
190. Miller MR, Hankinson J, Brusasco V, Burgos F, Casaburi R, Coates A, et al. Standardisation of spirometry. *Eur Respir J.* 2005;26(2):319-38.
191. Jolley CJ, Luo YM, Steier J, Rafferty GF, Polkey MI, Moxham J. Neural respiratory drive and breathlessness in COPD. *Eur Respir J.* 2014.
192. Duiverman ML, de Boer EW, van Eykern LA, de Greef MH, Jansen DF, Wempe JB, et al. Respiratory muscle activity and dyspnea during exercise in chronic obstructive pulmonary disease. *Respir Physiol Neurobiol.* 2009;167(2):195-200.
193. Schmidt M, Kindler F, Gottfried SB, Raux M, Hug F, Similowski T, et al. Dyspnea and surface inspiratory electromyograms in mechanically ventilated patients. *Intensive Care Med.* 2013;39(8):1368-76.
194. Gibson GJ. Pulmonary hyperinflation a clinical overview. *Eur Respir J.* 1996;9(12):2640-9.
195. Elliott MW, Aquilina R, Green M, Moxham J, Simonds AK. A comparison of different modes of noninvasive ventilatory support: effects on ventilation and inspiratory muscle effort. *Anaesthesia.* 1994;49(4):279-83.
196. Electromedical BD. Instruction Manual for the NIPPY3+ Positive Pressure Ventilator. 2007(Version 1 ):35.
197. Chiumello D, Pelosi P, Croci M, Bigatello LM, Gattinoni L. The effects of pressurization rate on breathing pattern, work of breathing, gas exchange and patient comfort in pressure support ventilation. *Eur Respir J.* 2001;18(1):107-14.

198. Tuggey JM, Delmastro M, Elliott MW. The effect of mouth leak and humidification during nasal non-invasive ventilation. *Respir Med.* 2007;101(9):1874-9.
199. Nava S, Navalesi P, Gregoretti C. Interfaces and humidification for noninvasive mechanical ventilation. *Respir Care.* 2009;54(1):71-84.
200. Langer D, Ciavaglia CE, Neder JA, Webb KA, O'Donnell DE. Lung hyperinflation in chronic obstructive pulmonary disease: mechanisms, clinical implications and treatment. *Expert Rev Respir Med.* 2014;8(6):731-49.
201. Sassooun CS. Mechanical ventilator design and function: the trigger variable. *Respir Care.* 1992;37(9):1056-69.
202. Prinianakis G, Kondili E, Georgopoulos D. Effects of the flow waveform method of triggering and cycling on patient-ventilator interaction during pressure support. *Intensive Care Med.* 2003;29(11):1950-9.
203. Roze H, Repousseau B, Perrier V, Germain A, Seramondi R, Dewitte A, et al. Neuro-ventilatory efficiency during weaning from mechanical ventilation using neurally adjusted ventilatory assist. *Br J Anaesth.* 2013;111(6):955-60.
204. Liu L, Liu H, Yang Y, Huang Y, Liu S, Beck J, et al. Neuroventilatory efficiency and extubation readiness in critically ill patients. *Crit Care.* 2012;16(4):R143.
205. Suh ES, Mandal S, Harding R, Ramsay M, Kamalanathan M, Henderson K, et al. Neural respiratory drive predicts clinical deterioration and safe discharge in exacerbations of COPD. *Thorax.* 2015;70(12):1123-30.
206. Atkeson AD, RoyChoudhury A, Harrington-Moroney G, Shah B, Mitsumoto H, Basner RC. Patient-ventilator asynchrony with nocturnal noninvasive ventilation in ALS. *Neurology.* 2011;77(6):549-55.
207. Vrijssen B, Testelmans D, Belge C, Vanpee G, Van Damme P, Buyse B. Patient-ventilator asynchrony, leaks and sleep in patients with amyotrophic lateral sclerosis. *Amyotrophic lateral sclerosis & frontotemporal degeneration.* 2016;17(5-6):343-50.
208. Murphy PB, Arbane G, Ramsay M, Suh ES, Mandal S, Jayaram D, et al. Safety and efficacy of auto-titrating noninvasive ventilation in COPD and obstructive sleep apnoea overlap syndrome. *Eur Respir J.* 2015;46(2):548-51.
209. Ekkernkamp E, Storre JH, Windisch W, Dreher M. Impact of intelligent volume-assured pressure support on sleep quality in stable hypercapnic chronic obstructive pulmonary disease patients: a randomized, crossover study. *Respiration.* 2014;88(4):270-6.
210. Kelly JL, Jaye J, Pickersgill RE, Chatwin M, Morrell MJ, Simonds AK. Randomized trial of 'intelligent' autotitrating ventilation versus standard pressure support non-invasive ventilation: impact on adherence and physiological outcomes. *Respirology.* 2014;19(4):596-603.
211. Kuo NY, Tu ML, Hung TY, Liu SF, Chung YH, Lin MC, et al. A randomized clinical trial of neurally adjusted ventilatory assist versus conventional weaning mode in patients with COPD and prolonged mechanical ventilation. *Int J Chron Obstruct Pulmon Dis.* 2016;11:945-51.
212. Xu J, Yuan H, Wu YX, Xiao SC, Zhang HJ, Luo YM. [Neural respiratory drive and nocturnal hypoventilation in patients with chronic obstructive pulmonary disease]. *Zhonghua Yi Xue Za Zhi.* 2013;93(6):411-4.
213. Machaalani R, Evans CA, Waters KA. Objective adherence to positive airway pressure therapy in an Australian paediatric cohort. *Sleep Breath.* 2016.
214. Ennis J, Rohde K, Chaput JP, Buchholz A, Katz SL. Facilitators and Barriers to Noninvasive Ventilation Adherence in Youth with Nocturnal Hypoventilation Secondary to Obesity or Neuromuscular Disease. *Journal of clinical sleep medicine : JCSM : official publication of the American Academy of Sleep Medicine.* 2015;11(12):1409-16.
215. Hull J, Aniapravan R, Chan E, Chatwin M, Forton J, Gallagher J, et al. British Thoracic Society guideline for respiratory management of children with neuromuscular weakness. *Thorax.* 2012;67(Suppl 1):i1-i40.
216. Contal O, Adler D, Borel JC, Espa F, Perrig S, Rodenstein D, et al. Impact of different back-up respiratory rates on the efficacy of non-invasive positive pressure ventilation in obesity hypoventilation syndrome: a randomized trial. *Chest.* 2012.
217. Ambrosino N, Foglio K, Rubini F, Clini E, Nava S, Vitacca M. Non-invasive mechanical ventilation in acute respiratory failure due to chronic obstructive pulmonary disease: correlates for success. *Thorax.* 1995;50(7):755-7.

Appendix 1: Physician led protocolised set-up of HMV a) COPD patients, b) OSA/OHS patients and c) NMD patients

a) **Lane Fox Unit Ventilator Set-up**  
Updated 2013



©2011 GUY'S AND ST THOMAS' NHS FOUNDATION TRUST. ALL RIGHTS RESERVED.  
LANE FOX RESPIRATORY UNIT

b)

## Lane Fox Unit Ventilator Set-up

Updated 2013



©2011 GUY'S AND ST THOMAS' NHS FOUNDATION TRUST. ALL RIGHTS RESERVED.  
LANE FOX RESPIRATORY UNIT

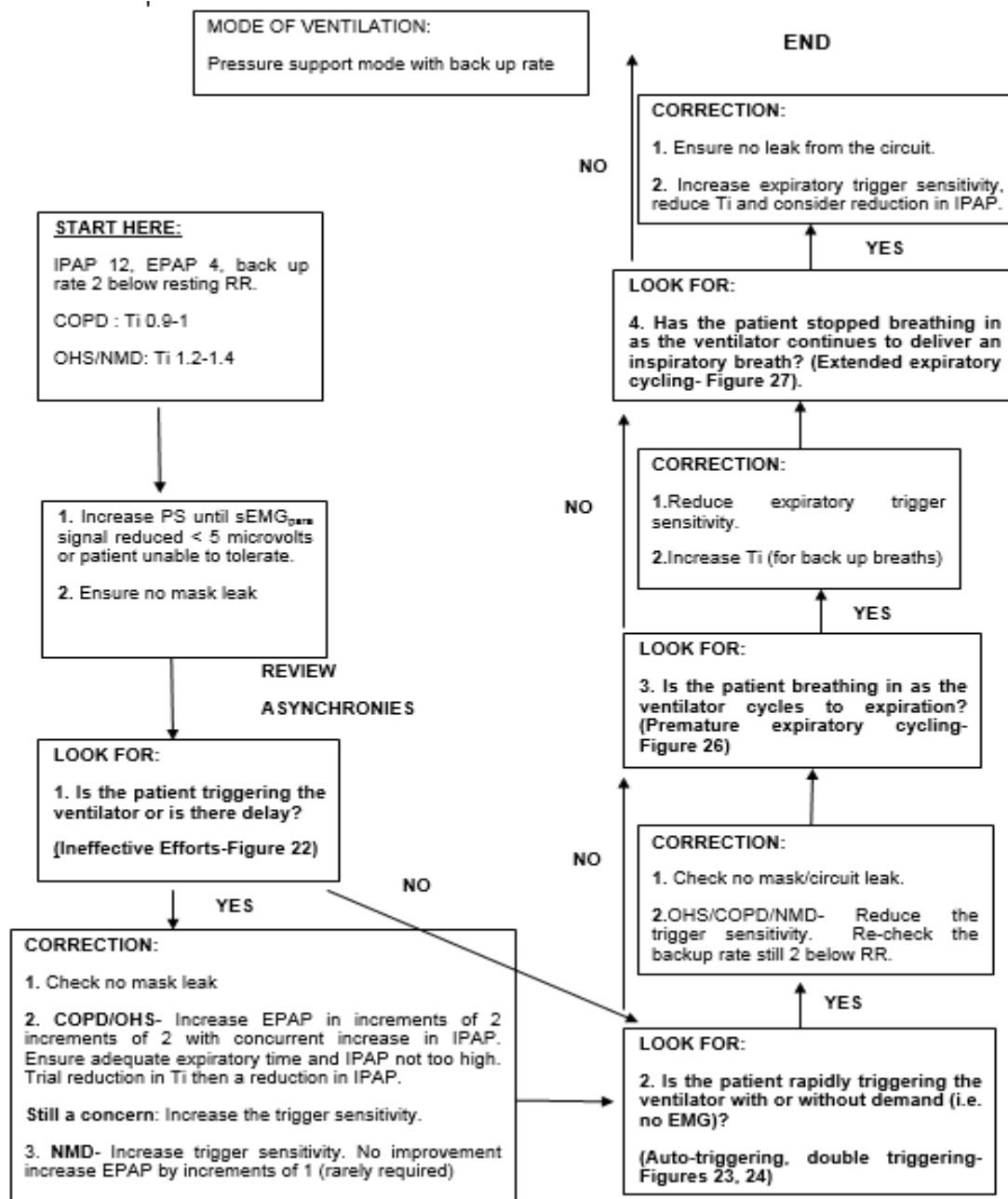
c)

## Lane Fox Unit Ventilator Set-up Updated 2013



©2011 GUY'S AND ST THOMAS' NHS FOUNDATION TRUST. ALL RIGHTS RESERVED.  
LANE FOX RESPIRATORY UNIT

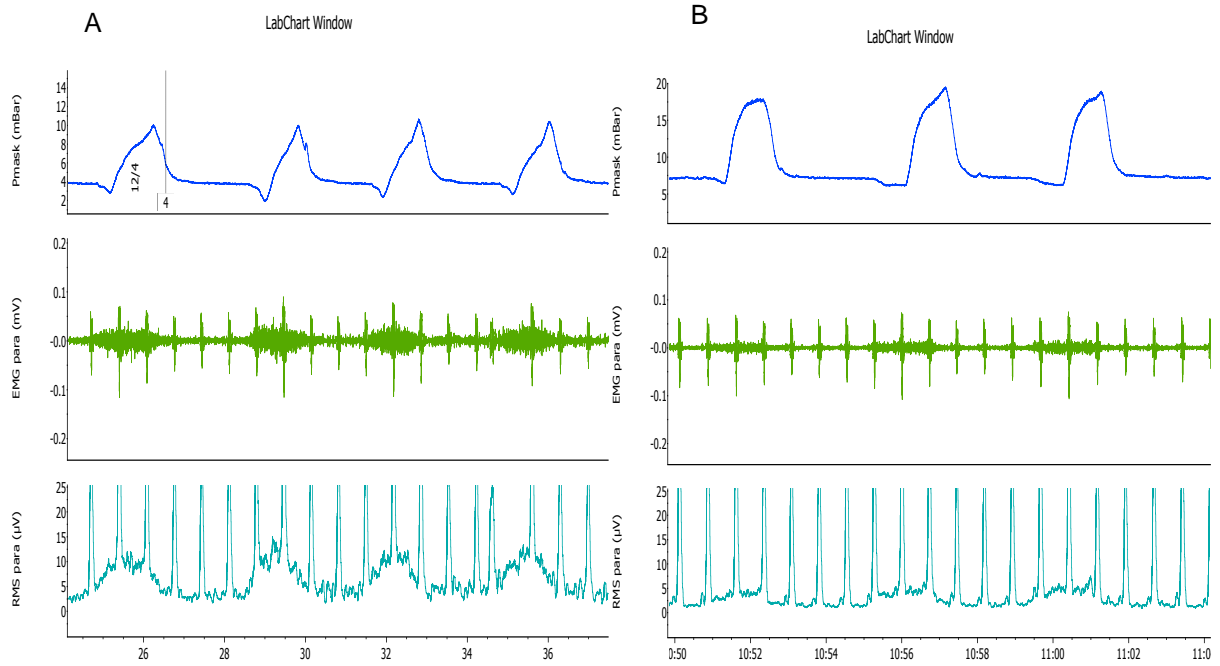
Appendix 2: Intervention (sEMGpara) led HMV titration protocol



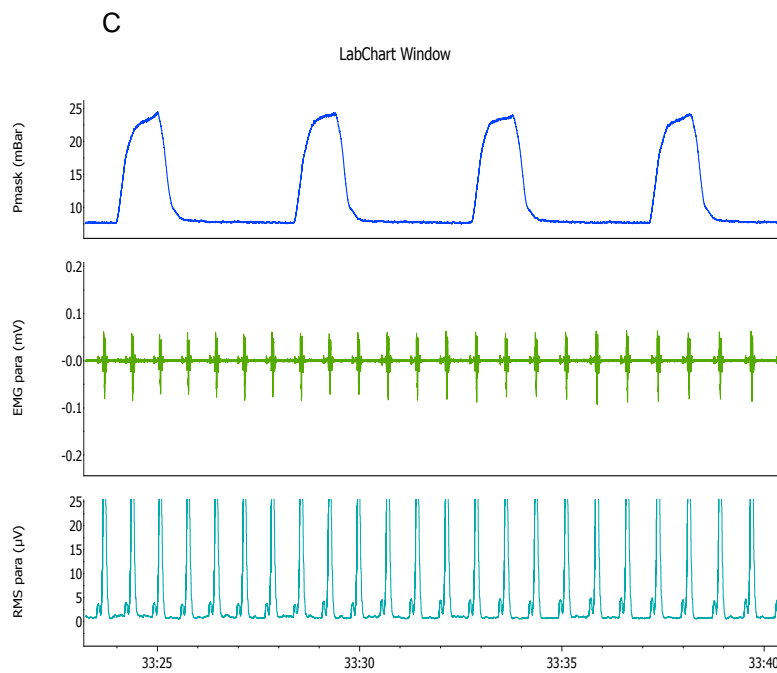
Appendix 2: A case example of sEMGpara led titration of HMV

Patient details: 61 year old female COPD/OSA, FEV1 0.7L (35%), FVC 2.00L (84%),

Weight 100kg, BMI 41.6 kg/m<sup>2</sup>, PaO<sub>2</sub> 5.4kPa, PaCO<sub>2</sub> 9.4kPa, HCO<sub>3</sub> 40mmol/L, pH 7.37



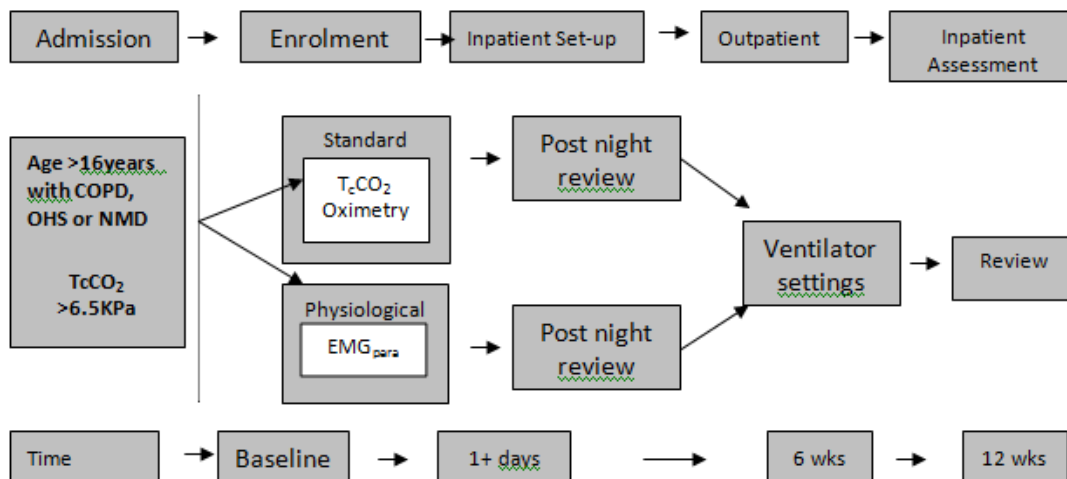
Starting settings: A) IPAP 12, EPAP 4, Ti 1sec, BUR10    B) IPAP 20, EPAP 6, Ti 1sec, BUR 12



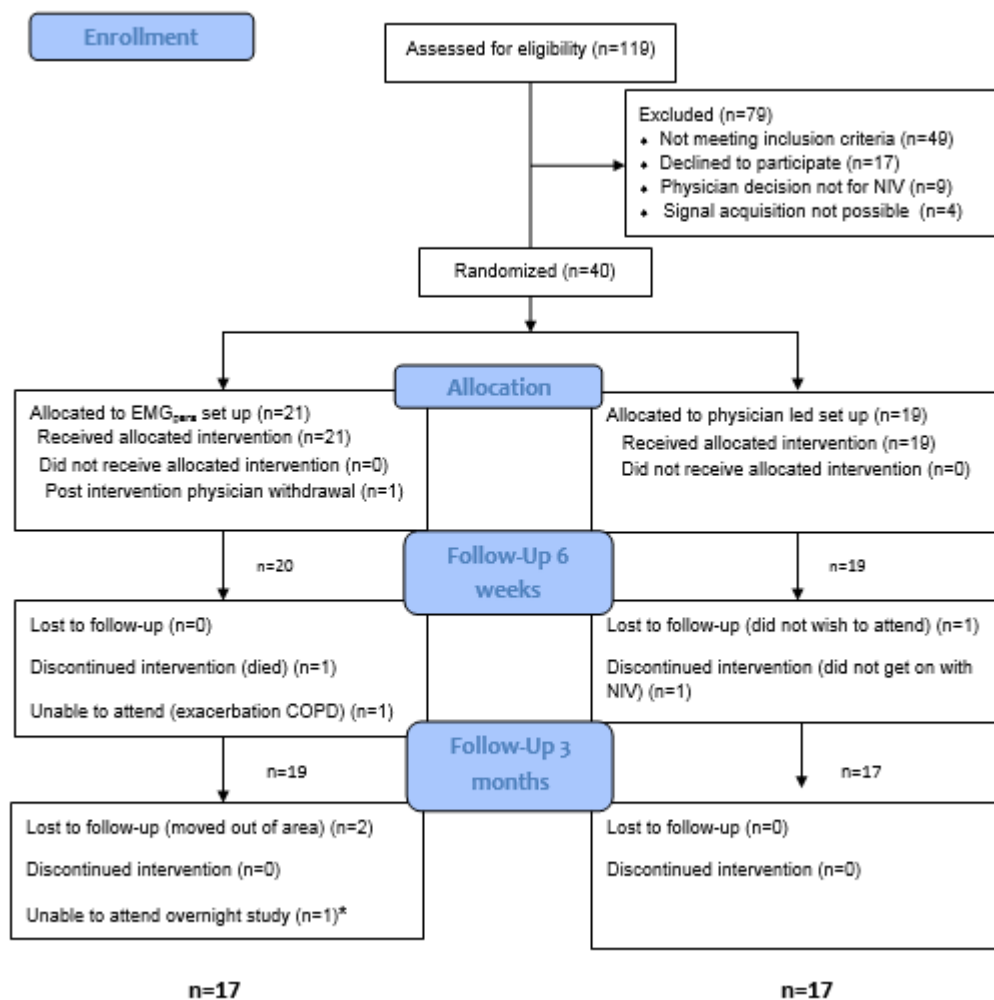
Final settings C):

- 1) Titrated IPAP 12 to 28
- 2) Titrated EPAP 4-8 (ineffective efforts)
- 3) Reduced inspiratory trigger from 4 to 2
- 4) Adjusted mask leak

Appendix 3: Outline of study timings



Appendix 4: Trial Consort Diagram



Appendix 5: PSG scoring agreement of 10 studies between myself (MR) and an ASA accredited sleep technician

PSG studies	Agreement (%)	Kappa	Score
1 (9/9/13)	92.8	0.90	Very good
2 (27/9/13)	92.4	0.90	Very good
3 (22/8/13)	93.9	0.92	Very good
4 (26/9/13)	94.9	0.93	Very good
5 (20/9/13)	93.8	0.92	Very good
6 (6/9/13)	92.5	0.91	Very good
7 (20/9/13)	94.5	0.92	Very good
8 (3/10/13)	93.2	0.91	Very good
9 (21/10/13)	93.2	0.90	Very good
10 (30/9/13)	95.1	0.93	Very good

Appendix 6: Patient -Ventilator Asynchrony Questionnaires

Patient-Ventilator Asynchrony Questionnaire

Age:

Height:

Weight:

Spirometry: FEV1/ FVC

Oxygen Sats:

Date of Starting Ventilation:

Ventilator model:

Ventilator Settings:

Please circle below:

1) Have you noticed any difficulties in co-ordinating your breathing with your ventilator? YES

NO

If YES please answer question 2- 5. If NO thank you very much for contribution to this survey.

2) Do you sometimes try to breath in but the ventilator does not respond to you?

YES NO

3) Does your ventilator sometimes give you a breath unexpectedly or without you asking for one?

YES NO

4) Do you sometimes try to breathe out but your ventilator continues to give you a breath in?

YES NO

5) Does the ventilator stop giving you a breath in whilst you are still trying to finish breathing in?

YES NO

Appendix 7: Patient Ventilator Interaction Questionnaire (PVIQ)

**Illness perception questions for patients requiring NIV**

Has your doctor and/or nurse explained your particular breathing problem to you?	Completely Reasonably well Fairly well A little Not at all
Do you understand about the breathing problem that you have?	Completely Reasonably well Fairly well A small amount Not at all
Has the doctor and/or nurse explained the treatment to you?	Completely Reasonably well Fairly well A little Not at all
Do you think that using your ventilator machine overnight is a useful treatment?	Yes No

	Probably
--	----------

**Patient – Ventilator Interaction Score**

Please circle the answer that best applies to you

1. Do you feel better since starting on your machine?	Yes  No
2. Does your breathing feel comfortable on the machine?	Always  Often  Occasionally  Never
3. Does the mask or ventilator stop you getting off to sleep?	Never  Occasionally  Often  Always
4. Do you sleep well when using the machine?	Always  Often  Occasionally  Never
5. Can you get back off to sleep on the ventilator after waking in the	Always

night?	Often Occasionally Never
6. Do you wake refreshed in the morning?	Always Often Occasionally Never
7. When you breathe IN, does the machine breathe with you?	Always Often Occasionally Never
8. Do you sometimes breathe IN but the machine does not give you a breath?	Never Occasionally Often Always
9. Are the breaths the ventilator gives you sometimes too short?	Never Occasionally Often Always
10. Are the breaths the ventilator gives you sometimes too long?	Never Occasionally

	Often Always
11. Overall, does the ventilator give you a big enough breath in?	Always Often Occasionally Never
12. Does the machine let you breathe out when you want to?	Always Often Occasionally Never
13. Are there times when the machine gives you another breath while you are trying to breathe out?	Never Occasionally Often Always
14. Does the ventilator sometimes give you an extra breath unexpectedly?	Never Occasionally Often Always
15. Do you have enough time from finishing one breath before the next breath comes?	Always Often Occasionally

	Never
16. Do you sometimes wait a long time for another breath from the ventilator?	Never Occasionally Often Always
17. Do you find it an effort to breathe out?	Never Occasionally Often Always
18. Is your mask comfortable?	Yes No
19. Does your mask leak?	Never Occasionally Often Always

Please circle which type of mask you use:

a) Nasal mask

d) Total face

b) Nasal pillows

c) Full face (nose and mouth)

**Thank you for your help**

## Appendix 7: Publications during PhD training

- 1) Ramsay M, Mandal S, Suh ES, Steier J, Douiri A, Murphy PB, Polkey M, Simonds A, Hart N. Parasternal electromyography to determine the relationship between patient-ventilator asynchrony and nocturnal gas exchange during home mechanical ventilation set-up. *Thorax*. 2015 Oct;70(10):946-52.
- 2) Ramsay M, Hart N. Current opinions on non-invasive ventilation as a treatment for chronic obstructive pulmonary disease. *Curr Opin Pulm Med*. 2013 Nov;19(6):626-30.
- 3) Murphy PB, Arbane G, Ramsay M, Suh ES, Mandal S, Jayaram D, Leaver S, Polkey MI, Hart N. Safety and efficacy of auto-titrating non-invasive ventilation in COPD and obstructive sleep apnoea overlap syndrome. *Eur Respir J*. 2015 Aug;46(2):548-51
- 4) Vrijsen B, Chatwin M, Contal O, Derom E, Janssens JP, Kampelmacher MJ, Muir JF, Pinto S, Rabec C, Ramsay M, Randerath WJ, Storre JH, Wijkstra PJ, Windisch W, Testelmans D. Hot Topics in Non-invasive Ventilation: Report of a Working Group at the International Symposium on Sleep-Disordered Breathing in Leuven, Belgium. *Respir Care*. 2015 Sep;60(9):1337-62
- 5) Suh ES, Mandal S, Harding R, Ramsay M, Kamalanathan M, Henderson K, O'Kane K, Douiri A, Hopkinson NS, Polkey MI, Rafferty G, Murphy PB, Moxham J, Hart N. Neural respiratory drive predicts clinical deterioration and safe discharge in exacerbations of COPD. *Thorax*. 2015 Dec;70(12):1123-30
- 6) Ramsay M, Polkey MI, Hart N. Chapter 64: Diseases of the Thoracic Cage and Respiratory Muscles, *Clinical Respiratory Medicine (4<sup>th</sup> Edition)*, Elsevier Health Sciences (2012) Editor: Stephen Spiro, Series Editor: Saunders WB.
- 7) Ramsay M, Polkey MI. Chapter 12: Non-invasive ventilation and chronic obstructive pulmonary disease. *Challenging concepts in respiratory medicine, Cases with expert commentary*. Oxford University Press (2017). Editors: Nicholas Hart, Lucy Schomberg, Elizabeth Sage. Series Editors: Aung Myatt, Shouvik Haldar, Simon Redwood.

