



King's Research Portal

DOI:

[10.1016/j.jad.2017.12.050](https://doi.org/10.1016/j.jad.2017.12.050)

Document Version

Peer reviewed version

[Link to publication record in King's Research Portal](#)

Citation for published version (APA):

Lund, C., & Cois, A. (2017). Simultaneous social causation and social drift: Longitudinal analysis of depression and poverty in South Africa. *Journal of Affective Disorders*. <https://doi.org/10.1016/j.jad.2017.12.050>

Citing this paper

Please note that where the full-text provided on King's Research Portal is the Author Accepted Manuscript or Post-Print version this may differ from the final Published version. If citing, it is advised that you check and use the publisher's definitive version for pagination, volume/issue, and date of publication details. And where the final published version is provided on the Research Portal, if citing you are again advised to check the publisher's website for any subsequent corrections.

General rights

Copyright and moral rights for the publications made accessible in the Research Portal are retained by the authors and/or other copyright owners and it is a condition of accessing publications that users recognize and abide by the legal requirements associated with these rights.

- Users may download and print one copy of any publication from the Research Portal for the purpose of private study or research.
- You may not further distribute the material or use it for any profit-making activity or commercial gain
- You may freely distribute the URL identifying the publication in the Research Portal

Take down policy

If you believe that this document breaches copyright please contact librarypure@kcl.ac.uk providing details, and we will remove access to the work immediately and investigate your claim.

Author's Accepted Manuscript

Simultaneous social causation and social drift:
Longitudinal analysis of depression and poverty in
South Africa

Crick Lund, Annibale Cois

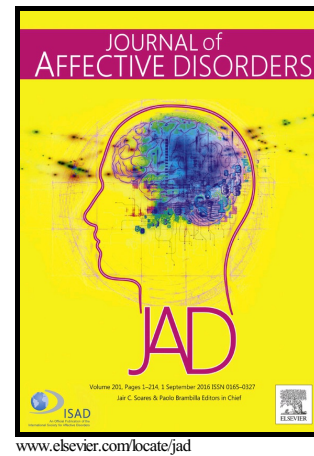

PII: S0165-0327(17)32023-2
DOI: <https://doi.org/10.1016/j.jad.2017.12.050>
Reference: JAD9458

To appear in: *Journal of Affective Disorders*

Received date: 29 September 2017
Revised date: 12 December 2017
Accepted date: 27 December 2017

Cite this article as: Crick Lund and Annibale Cois, Simultaneous social causation and social drift: Longitudinal analysis of depression and poverty in South Africa, *Journal of Affective Disorders*, <https://doi.org/10.1016/j.jad.2017.12.050>

This is a PDF file of an unedited manuscript that has been accepted for publication. As a service to our customers we are providing this early version of the manuscript. The manuscript will undergo copyediting, typesetting, and review of the resulting galley proof before it is published in its final citable form. Please note that during the production process errors may be discovered which could affect the content, and all legal disclaimers that apply to the journal pertain.

Simultaneous social causation and social drift: Longitudinal analysis of depression and poverty in South Africa

Crick Lund^{1,2*}, Annibale Cois³

¹ Alan J Flisher Centre for Public Mental Health, Department of Psychiatry and Mental Health, University of Cape Town, South Africa.

² Centre for Global Mental Health, Institute of Psychiatry, Psychology and Neuroscience, King's College London, United Kingdom.

³ Division of Epidemiology and Biostatistics, School of Public Health and Family Medicine, University of Cape Town, South Africa.

*Correspondence to: Professor Crick Lund, Alan J Flisher Centre for Public Mental Health, Department of Psychiatry and Mental Health, University of Cape Town, 46 Sawkins Road, Rondebosch, South Africa. Telephone: +27216850120. crick.lund@uct.ac.za.

Abstract

Background:

Two theories have been proposed to explain the observed association between depression and poverty, namely social causation and social drift. Little is known regarding the relative importance of social causation and social drift in low and middle-income countries, where poverty is more severe and where most of the world's depressed individuals live.

Methods:

We analysed nationally representative longitudinal data from the National Income Dynamics Study in South Africa and simultaneously tested social causation and social drift hypotheses using structural equation modelling across three waves.

Results:

Worse individual economic status at time 1 and 2 was independently associated with worse depression two years later at time 2 (standardised linear regression coefficient $\beta=-0.110$, Standard Error (SE): 0.024) and four years later at time 3 ($\beta=-0.113$, SE: 0.025) respectively. Conversely worse depression at time 1 and time 2 was independently associated with worse economic status at time 2 ($\beta=-0.037$, SE: 0.016) and time 3 ($\beta=-0.028$, SE: 0.012) respectively. In addition, the "effect" of depression on future assets was stronger among people with less baseline assets.

Limitations:

The time span between data rounds is relatively short (four years); response rates are unequal across ethnic, age and sex groups; and the measure of depression is based on self-report.

Conclusions:

Social causation and social drift act simultaneously in this population, reinforcing poverty/depression cycles. Multi-sectoral policies are required that both prevent depression by addressing its economic determinants, and provide evidence-based treatment to mitigate the economic impact of depression.

Keywords: Depression, poverty, social causation, social drift, low and middle-income countries, South Africa

Introduction

Depression is a leading cause of health disability globally, and its importance in low and middle-income countries (LMIC) is predicted to increase with demographic and epidemiological transitions (Whiteford et al., 2013). Depression has also been strongly associated with poverty and deprivation in LMIC (Lund et al., 2010). These countries carry the greatest burden of poverty (World Bank, 2015b) and most of the world's depressed individuals live in LMIC (Whiteford et al., 2013). Yet little is known about the causal relationships underlying the observed association between depression and poverty in these countries: do circumstances of poverty lead to higher prevalence of depression or do the disability and increased healthcare expenditure associated with depression lead individuals to drift into, or remain in, poverty? Furthermore, do the circumstances in LMIC require us to revise our global view on the poverty/depression relationship, given that the current views on this relationship are based almost entirely on findings from high-income countries? Until recently there has been a dearth of longitudinal datasets in LMIC that allow for exploration of this relationship (Lund et al., 2011). In their classic 1992 study, Dohrenwend and colleagues demonstrated the social causation and social selection (sometimes referred to as social drift) mechanisms of the relationship between poverty and mental health, using a sample from Israel (Dohrenwend et al., 1992). Briefly stated, the social causation hypothesis proposes that the adverse social and economic conditions of poverty (such as financial stress, increased exposure to violence, increased adverse life events such as negative income shocks, lower education, food insecurity, income insecurity and reduced

resources to protect individuals from the consequences of adverse life events) increase risk for mental illness. Conversely, the social selection/drift hypothesis proposes that people living with mental illness drift into poverty during the course of their lives, due to disability, reduced economic productivity, increased stigma and increased health expenditure caused by their illness. Through consideration of the relative effects of ethnicity and socio-economic status, Dohrenwend and colleagues demonstrated that social causation applied more readily to depression, whereas social selection/drift was more applicable to schizophrenia. In a subsequent US study of rural women, social causation was found to provide a better explanation of the association between low economic status and depression than social selection/drift (Simmons et al., 2008), and a similar trend was found for the association between food insecurity and depression (Huddlestone-Casas et al., 2009). This distinction has frequently led to discounting of the importance of social selection/drift in explaining the observed association between poverty and depression (Saraceno et al., 2005).

This is borne out by the focus of research that has been conducted in LMIC to date. We updated our previous systematic literature review of studies published between 1990 and 2008 (Lund et al., 2010), to search for longitudinal studies published between 2008 and the present that examined the relationship between depression and poverty in LMIC (see Supplementary information for search methods and findings). All of the 13 included longitudinal studies examined the effect of poverty on depression (social causation), and none examined the effect of depression on poverty status (social drift).

Despite this trend in the epidemiological literature, many of the proposals to address the major population level burden of depression have focused on attempts to scale up mental health treatment services, addressing the social drift pathway, for example in the first Lancet Series on

Global Mental Health in 2007, which called for action to scale up mental health services (Lancet Global Mental Health Group, 2007). Indeed this was also the focus of a major international Delphi priority setting exercise to identify the grand challenges in global mental health, published in *Nature* in 2011 (Collins et al., 2011). Of the top five research priorities identified, all focused on the need for research on improved detection and treatment, and none of the top five addressed the need to understand the social determinants of mental health, including the effects of poverty and other social risk factors on mental health (although these were addressed to some extent in some of the lower priority research questions). The notion that social causation and social drift might occur simultaneously in the case of depression has not been addressed in global mental health research, either as a potential area for further research enquiry or an approach to adopt in policy. To our knowledge no previous studies have simultaneously examined social causation and social drift pathways in the same population in LMIC.

Data from the nationally representative South African National Income Dynamics Study (NIDS) offer the first opportunity to concurrently test the two hypotheses which explain the observed inverse relationship between poverty and depression in LMIC, namely social causation and social drift. The NIDS dataset is novel in LMIC because it offers longitudinal data (i.e., the temporal order can be recovered), a large nationally representative sample, a large set of socio-economic indicators, and a standardised measure of depression: the Centre for Epidemiological Studies Depression (CES-D) scale (Radloff, 1977). The perspective from South Africa is potentially instructive for our global knowledge of the mechanisms of poverty and mental health in two further ways: firstly, poverty is more extreme than in the high-income country contexts in which social causation and social drift theories have been formulated: according to latest estimates, 21% of South Africa's population live in extreme poverty (below the food poverty line

of \$25 consumption per capita per month), 39% below the lower bound poverty line (\$39 per month), and 63% below the upper bound poverty line (\$76 per month) (Budlender et al., 2015). Secondly, income inequality is more pronounced, with South Africa's Gini coefficient currently at 65.0, among the highest in the world (World Bank, 2015a). In addition to scientific importance, the findings are potentially significant from a policy perspective. Until the adoption of the Sustainable Development Goals, consideration of the role of depression in maintaining poverty has been largely ignored in national and international development policy, and mental health was invisible in the targets of the Millennium Development Goals (Miranda and Patel, 2005). The purpose of this article is to report the first comparison of the relative importance of social causation and social drift mechanisms in the poverty/depression association in LMIC.

Methods

Study participants

The NIDS is the first nationally representative longitudinal household study in South Africa. It is implemented by the Southern Africa Labour and Development Research Unit (SALDRU) in the School of Economics at the University of Cape Town (UCT) in order to track changes in poverty over time (Unit, 2014). The NIDS is a multi-dimensional study that collects individual, household and neighborhood level longitudinal data, including assessments of income, assets, multiple deprivation and depression, among other variables. A stratified two-stage cluster sample design was employed to determine which households would be included in the base wave of the study. The sample comprised private households from every province, with 400 sampling units mirroring a master sample employed for the national census in South Africa.

Wave 1 of the sample was conducted in 2008 with a nationally representative sample of 28,226 individuals in 7,296 households. The response rate for households in wave 1 was 69%, and the individual response rate within each household was 93.3%. The survey was repeated with the same household members every two years, following up individuals who change their household location over time, and enrolling the new children of women participants. The individual attrition rate was 19% between wave 1 and wave 2, and 16% between wave 2 and wave 3. Data from waves 1, 2 and 3 (collected in 2008, 2010-2011 and 2012 respectively) are publically available.

Of the whole NIDS dataset, this study considers the subset of 11,440 individuals who were 15 years of age or older at the time of the first interview and who were successfully re-interviewed both in the second and the third wave (see Supplementary Data Figure 1). Sampling weights were adjusted to take into account unequal response rates across population strata (De Villiers et al., 2013). Wave 1 dataset version 5.2, Wave 2 version 2.2, and Wave 3 version 1.2 were used in the analyses.

Measures

Sociodemographic variables:

Education was measured in years of completed schooling and categorised as Primary, Secondary, Tertiary and None. Race was self-defined by participants according to the historical 'population group' categorization used in South Africa. Under apartheid, South Africans were categorised into one of four socially defined groups: Asian (or Indian), Black (or African), Coloured (wide grouping of people of mixed ancestry) and White (or European). Place of residence was categorised as urban/rural according to definitions of Statistics South Africa's Census

2001(Statistics South, 2003). Household monthly income per capita was calculated as the summation of a wide array of sources, as detailed by Argent (Argent, 2009). Participants were categorised as employed, unemployed or not economically active as per Statistics South Africa official classification.

Poverty:

Poverty is a complex concept, which has been variously defined in “absolute” terms (referring to a fixed level of income), “relative” terms, (referring to the level of income in relation to the mean or median of a given population) or “multi-dimensional” terms (a range of indicators of social and economic deprivation, sometimes combined in a composite index of multiple deprivation, such as the Human Development Index, or the Index of Multiple Deprivation) (Toye and Infanti, 2004). In order to best examine the relationship between depression and poverty, we required a measure of poverty that met the following criteria: (1) it should be a continuous variable as this would be more responsive to change and minimise loss of statistical power; (2) it should be a reliable measure, leading us to exclude income, which is frequently an unreliable measure especially in informal economies where it can be inconsistent, or under-reported for fear of exclusion from social grants or penalisation for undeclared taxable income (Deaton, 1997); (3) it should not be multidimensional as this complicates the analysis of its relationship with depression and exacerbates problems of confounding; and (4) it should minimise problems of confounding, for example it should exclude subjective ratings of financial distress, which might be confounded by mood. To avoid these difficulties, we drew on the work of Townsend (Townsend, 1987) who defined deprivation as a measure of the extent of unmet needs, and *poverty as the lack of resources required to meet those needs*. Therefore in order to measure the

resources available to individuals and households, we used exploratory factor analysis (EFA) to identify two latent constructs (individual and household resources or assets) underlying the large set of indicators included in NIDS to represent goods ownership and access to resources.

Similarly to Filmer & Pritchett's (Filmer, 2001) approach adopted by the World Bank in the analyses of the Demographic and Health Surveys data, a single-factor EFA solution was considered for each index, and indicators with factor loadings < 0.6 were discarded.

The 10 indicators included in the **individual asset index** were personal ownership of: radio, stereo, motor vehicle for private use, motor vehicle for commercial use, scooter, bicycle, computer, camera, sewing machine and cellphone. The 21 indicators included in the **household asset index** were: (1) household ownership of: fridge, microwave, camera, electric stove, satellite dish, private and commercial motor vehicle, TV, computer, VCR/DVD player, lounge suite, stereo, scooter, sewing machine; (2) characteristics of the house: brick walls, tiled roof, electricity, piped water, flush toilet with onsite and offsite disposal; and (3) sources of energy for cooking: electricity.

Depression:

we measured depression by defining a latent variable whose indicators were the items constituting the short 10-item version of the Centre for Epidemiological Studies Depression scale (CES-D 10). The scale was originally developed by Radloff to measure depression in the general adult population (Radloff, 1977), and is among the top five most commonly used self-report measures for depression (Wood et al., 2010). The shortened version has been shown to lose little of the psychometric properties of the original 20-item version (Shrout, 1989). The

questions ask about the frequency of symptoms or experiences of depression during the past week. Responses are scored on a 4-point Likert scale, ranging from ‘rarely or none of the time’ to ‘all of the time’, and a higher score represents more severe depression.

It has been previously observed in literature that the positively worded items of the CESD-10 (and, similarly, of its original long version) do not perform adequately in various populations (Cheng et al., 2006; Radloff, 1977). This was the case in our sample, where the two items showed extremely low correlation with the rest of the scale in all waves and, moreover in the wrong direction. Item-rest correlations varied between +0.19 and +0.30 for item 5 ("I was happy"), and between 0.02 and 0.12 for item 8 ("I felt hopeful about the future"). Therefore these items were excluded from the indicators of the latent variable measuring depression.

Statistical analyses

Sample characteristics were described as the median and interquartile range for continuous variables and frequency for categorical measures. We used structural equation modelling to simultaneously estimate the relationships between the latent constructs representing individual and household assets at each time point and depression at the following time point, and vice-versa. As per standard procedure in structural equation modelling, the relationship between latent constructs and their indicators (measurement model) were also simultaneously estimated, in terms of factor loadings. Standardised factor loadings are shown in Supplementary Data Table 7 and 8.

Given the short period of time separating the subsequent waves of the survey (approximately 2 years), we assumed stability of the relationships between poverty and depression during the whole period of observation. The cross-lagged structure of the model is depicted in Figure 1.

Prior to the estimation of the structural parameters, we assessed the validity of the measurement model for the latent variables measuring depression, individual assets and household assets. The agreement of the measurement model with the data (model fit) was assessed using multiple indices, and the compatibility of the measurements across waves was tested by constraining the relevant measurement parameters to be equal across time and comparing the fit of the model with the unconstrained version (Cheung, 2002).

The upper part of Supplementary Data Table 1 reports the fit indices for the measurement models. Considering the large sample size which justifies the significant value for the χ^2 test, the other indices of model fit indicate an adequate fit with the data, according to the common thresholds in literature (Root Mean Square Error of Approximation (RMSEA) < 0.08 with a non-significant p-value, Comparative Fit Index (CFI) and Tucker Lewis Index (TLI) > 0.90) (Hooper, 2008). Constraining the values of the factor loadings to be equal across the three waves produced a significant decrease in model fit according to the χ^2 test, but only modest changes in RMSEA, CFI and TLI, well below the thresholds that indicate meaningful deterioration of model fit (0.05 for RMSEA and CFI, and 0.01 for TLI). Overall, these results support the hypothesis that our measures of depression and assets perform similarly across waves (metric invariance), making it meaningful to use them to assess longitudinal relationships (Cheung, 2002).

Similarly, we tested the plausibility of the hypothesis of temporal stability of the relationship between depression and poverty by comparing the fit of the model with the structural coefficients constrained to be equal across waves (as a formal representation of the stability hypothesis) with a reference model where this constraint was removed. The results supported the validity of our assumption (differences in RMSEA, TLI and CFI < 0.01 for both the individual and household asset model).

The reliability of the depression and poverty measures was calculated from the model estimates as the proportion of the total variance of the indicators explained by the underlying latent variable (Raykov, 2001). All three measures showed adequate reliability in each wave ($\rho > 0.86$ for depression, $\rho > 0.95$ for the household asset index and $\rho > 0.89$ for the individual asset index).

The full structural models depicted in Figure 1 (one including individual assets and the other household assets) also showed adequate fit with the data, as indicated by the values of the fit indices in the lower part of Supplementary Data Table 1.

The estimates were statistically adjusted for gender, race and baseline age and categorical education. Significance level for hypothesis testing was set at $\alpha = 0.05$.

The estimation of the models was performed using Mplus Statistical Software v. 7.3 (Muthén&Muthén, Los Angeles), taking into account the categorical nature of the indicators and the complex sampling scheme of the NIDS through the use of a weighted least square mean and variance adjusted (WLSMV) estimator. Missing data were incorporated in the analyses under the

assumption that they were missing at random conditional on the observed covariates (Asparouhov and Muthen, 2010).

Ethics

Ethical approval for NIDS was granted by the University of Cape Town Commerce Faculty Ethics Committee. Informed consent was obtained from all subjects participating in the study.

Results

Unweighted sample characteristics at wave 1 are shown in Table 1.

Table 2 summarises the distribution of the depression scores in the sample calculated as the sum of the scores in each of the 10 items of the CESD-10 scale, as well as the percentage of participants with scores above the cut-off of 12, considered as indicative of depression in South African populations (Baron et al., 2017). Additional information regarding the proportion of participants with missing information for depression and asset indices in each wave is provided in Supplementary Data Table 2. Descriptive statistics of baseline characteristics of subjects lost to follow-up is provided in Supplementary Data Table 3.

Table 3 shows the linear regression coefficients for the structural relationships between individual and household asset indices and depression, adjusted for gender, race, continuous age and categorical education (β paths in Figure 1). Given the intrinsic arbitrariness and incomparability of the scales of the latent variables representing the constructs of interest,

coefficients are shown and interpreted in their standardised form in order to allow meaningful comparisons. The unstandardised model estimates are shown in Supplementary Data Table 4.

As shown in Table 3, the individual asset index in each wave was negatively and significantly correlated with depression in the following wave. Depression also significantly predicted reduced individual assets in the following wave. Similarly, the household asset index in each wave was negatively and significantly correlated with depression score in the following wave. However, the reverse was not true, and the association between depression score in a given wave and household assets at the following time point was not significant.

Regression coefficients between the same variable measured at different points in time were all statistically significant and relatively large in magnitude, compared to the 'cross-lagged' coefficients representing the association across waves between different variables. In substantive terms these results indicate that both depression and asset ownership are relatively stable quantities, the measures of which at a given point in time are largely affected by their value at the previous point. The magnitude of the cross-lagged coefficients is relatively small but nevertheless statistically significant and in the expected direction for all of them. As a benchmark, the standardised coefficients for the effect of assets on future depression in Table 3 are of the same order of magnitude of the standardised gender effects on depression (which are -0.057 between wave 1 and 2 and -0.036 between wave 2 and 3).

To further explore the relationship between depression and future poverty, we re-estimated a simplified version of the model in Figure 1 twice, including only the first two waves of data. In

the first model we introduced the baseline asset index as an effect modifier of the relationship between depression at wave 1 and individual assets at wave 2, and in the second model we relaxed the linearity assumption and we allowed for quadratic effects. From an analytical point of view the procedure, described in greater detail in the Supplementary Information, consisted in introducing in the model as an extra predictor of assets at wave 2, a latent interaction term between baseline depression and asset index in the first case and a latent quadratic term (baseline depression squared) in the second.

The low precision of the estimated regression coefficients of the new predictors does not allow for strong interpretation of the results. However, their values suggest both the presence of some degree of effect modification by baseline assets and nonlinearity of the relationship between depression and future poverty.

In the first case the magnitude and sign of the new regression coefficient – standardised $\beta = +0.006$ (se=0.03) vs. -0.048 for the main coefficient – suggest that the "effect" of depression on future assets tends to be stronger among people with less baseline assets. In the second case the magnitude of the coefficient of the quadratic term – standardised $\beta = +0.003$ (se=0.02) vs. -0.039 for the main coefficient) suggests the presence of a non-linear relationship, with slight reduction of the effect with increasing baseline depression. Supplementary Data Figure 2 and 3 depicts the results of these analyses.

Discussion

Within the limitations of a large scale observational study, our findings support the hypothesis that the causal mechanism underlying the observed association between depression and poverty

in a nationally representative sample of South African adults involves not only social causation but also social drift. The existence of a statistically significant association between depression scores at a given point in time and future asset ownership is coherent with the hypothesis of social drift, and cannot be attributed to reverse causation because of the temporal sequence implicit in the design of the study. Moreover, this association, albeit relatively small in magnitude, exists also after controlling for the association between asset ownership and future depression, which is coherent with the social causation hypothesis and is also found in our analyses. Importantly, among people with less asset resources at baseline, the effect of depression on individual assets is more pronounced, indicating the vulnerability of this group.

These findings partially support Dohrenwend's 1992 hypothesis regarding the importance of social causation in explaining the poverty-depression relationship (Dohrenwend et al., 1992). However, importantly they also demonstrate that there is substantial social drift and impoverishment due to depression when variables such as race, gender and baseline age and education are controlled for. This is the first time, to our knowledge that such a nationally representative longitudinal study has examined both social causation and social drift in a LMIC, and the first study to demonstrate that both social causation and social drift act simultaneously in a LMIC population, further reinforcing the poverty/depression relationship.

This is in keeping with recent findings reported by Haushofer and Fehr that the stress and negative affective states caused by poverty, may yield risk averse decision-making and discounting of future rewards, favouring habitual patterns over goal-directed behaviour

(Haushofer, 2014). Taken together these cognitive styles and related low mood may serve to perpetuate cycles of poverty.

There are several possible explanations for the finding that social drift is not significant for household assets. Chiefly, household assets are less malleable than individual assets, and therefore depression is less likely to have an effect on household assets than individual assets over this short time period.

The further analysis of the moderating effect of baseline depression and assets sheds more light on the potential mechanisms of these relationships, and identifies vulnerable populations who might benefit from interventions. For example the finding that the effect of depression on individual assets was more pronounced among individuals with lower baseline assets, indicates that the social drift pathway may be more pronounced among those who have less resources to buffer themselves against the economic impacts of depression. This indicates both a potential mechanism (the importance of material resources in protecting individuals against the economic impacts of depression), and a vulnerable group who could benefit from social protection interventions such as disability grants for mental illness, thus preventing social drift.

The strengths of the study are: (1) the large sample and the repeated measures design which allowed for a direct assessment of temporality in the poverty-depression relationship, excluding hypotheses of reverse causality which are difficult to deal with in cross-sectional studies; (2) the representation of the theoretical constructs of both depression and poverty through the use of latent variables with multiple indicators, within the framework of structural equation modelling. This choice allowed for an efficient treatment of random measurement error, with consequent

increase of the precision and plausible reduction of bias in the estimation of the regression coefficients of interest; (3) the estimation methods which take into account the binary nature of the indicators, relaxing the implausible distributional assumption underlying more traditional methods. This approach also allowed for an efficient treatment of missing data, under the hypothesis that they are missing at random conditional on the observed covariates; (4) we undertook further analysis using household income per capita as a measure of poverty (instead of individual and household assets) and calculated the standardized structural coefficients of the cross-lagged model where the logarithm of the household income per capita is substituted for the asset index. The log-transformed variable was introduced rather than the original household income per capita, on account of the extremely skewed distribution of the latter. Our findings once again indicate the presence of both social causation and social drift using household per capita income as the poverty measure. Depression at time 1 significantly predicts worse household per capita income at time 2, and conversely, household per capita income at time 1 predicts worse depression status at time 2. All relationships are statistically significant.

The limitations of the study are: (1) the time span between data rounds is relatively short (only two years between waves, for a total of four years); (2) response rates are very unequal across ethnic and age/sex groups, therefore representativeness of the population is questionable; (3) loss of respondents between waves is relatively small for a large scale survey, but still large enough to introduce bias. Levels of depression were similar at baseline among those subsequently retained in the study and those lost to follow-up. In relation to other variables, those lost to follow-up were predominantly those with higher socio-economic status (white, higher income and with more tertiary education), although this has been mitigated by the adjustment of the

sampling weights to take into account differential loss to follow-up (De Villiers et al., 2013); (4) the measure of depression is based on self-report and it might not adequately represent the underlying construct; (5) poverty is a complex multi-dimensional construct and asset ownership may have limitations as a proxy measure for poverty (although, as noted above the substitution of household per capita income for assets confirmed both social causation and social drift pathways); (6) the association between depression and poverty is likely to vary with age and gender, which we were not able to explore fully in this study; (7) at this stage there appears to be insufficient data to infer causality in these relationships; and (8) we cannot exclude the possibility of confounding, for example the absence of health insurance, self efficacy, physical health and genetic data, among other possible confounders make it impossible to directly take into account their effect in our estimates. However, the longitudinal nature of our data and the structure of the proposed models allow for statistical testing of the plausibility of the hypothesis that the observed associations are totally explained by the presence of external factors not accounted for in the model. From a conceptual point of view, the procedure consists in representing the possible unmeasured confounder(s) by means of a series of latent variables and to test if their presence is able to adequately explain the observed data in absence of the direct effects hypothesised in the cross-lagged model (Newsom, 2015). Two alternative models were tested against the data (the "Synchronous common factor" and the "hybrid" models (Newsom, 2015)): in both cases the overall fit of the model was significantly worse than the fit of the original cross-lagged model for the association between depression and individual asset index, with some of the indices assuming values incompatible with an acceptable fit (Supplementary Data Table 6). This provides evidence —albeit partial and conditional on the validity of the modeling assumptions described in the supplementary information — against the hypothesis that

the observed association between depression and future individual assets is only the result of the presence of unobserved confounding factors.

Previous research has shown that the increase in depression among the poor is attributable to increased life events and the lack of resources to cope with the consequences of those life events (Aneshensel, 2009; Dohrenwend et al., 1992). Consequently, to adjust for the confounding effect of negative life events on the relationship between low assets and depression we conducted further structural equation modeling. We introduced as a new confounder the number of negative life events experienced in the two previous years, a list of which is available in the NIDS dataset. As expected, the introduction of this confounder slightly reduces the size of the effect of depression on future assets, but the reduction is very small and does not change our interpretation. Qualitatively the same results also appear when binary versions of the number of life events, with different cutoffs, are introduced in the models. The new coefficients are presented in Supplementary Data Table 5.

In keeping with the recent inclusion of mental health targets in the new 2015 Sustainable Development Goals, the findings of this study demonstrate the broad economic impact of depression in South Africa. Our study supports the hypothesis that poverty and deprivation not only precede depression, but are also an important consequence of depression. Further research is required in other LMIC to assess the relative importance of social causation and social drift.

From a policy perspective, there are two important implications: firstly that more policy priority should be given to the detection and treatment of depression, particularly in primary health care, as depression appears to be an important predictor of poverty; and secondly that increased policy

attention should be given to the social determinants of depression at a population level. This requires more proactive social protection in the form of grants and bolstering savings and assets, in order to improve population mental health. Broad population level interventions to address poverty in LMICs like South Africa must therefore include robust prevention and treatment interventions for depression if cycles of poverty and mental illness are to be broken.

Acknowledgements

CL is supported by UK Aid, as part of the Programme for Improving Mental health care (PRIME). The views expressed in this manuscript are not necessarily those of the funders. We wish to thank Lucie Cluver, Sara Evans-Lacko and Johannes Haushofer for their comments on an earlier version of this manuscript, and Carrie Brooke-Sumner for her assistance with the systematic literature review.

Author contributions

CL led the design of the study and drafted the manuscript. AC led the statistical analysis and drafted parts of the Methods, Results and Discussion. Both authors approved the final manuscript.

Author Information

Data from waves 1, 2 and 3 (collected in 2008, 2010 and 2012 respectively) are publically available through the DataFirst portal at the University of Cape Town:

<http://www.nids.uct.ac.za/nids-data/data-access>. Reprints and permissions information is

available at www.nature.com/reprints. The authors declare that they have no competing financial

interests. Correspondence and requests for materials should be addressed to crick.lund@uct.ac.za.

Conflict of Interest statement

The authors declare that they have no conflict of interest.

References

- Aneshensel, C., 2009. Toward explaining mental health disparities. *Journal of Health and Social Behaviour* 50, 377-394.
- Argent, J., 2009. Household Income: Report on NIDS Wave 1. Technical Paper no. 3. Southern Africa Labour and Development Research Unit, Cape Town.
- Asparouhov, T., Muthen, B., 2010. Weighted least squares estimation with missing data. Technical Report., Retrieved October 4, 2013, from <http://www.statmodel.com/download/GstrucMissingRevision.pdf>.
- Baron, E.C., Davies, T., Lund, C., 2017. Validation of the 10-item Centre for Epidemiological Studies Depression Scale (CES-D-10) in Zulu, Xhosa and Afrikaans populations in South Africa. *BMC Psychiatry* 17, 6.
- Budlender, J., Leibbrandt, M., I., W., 2015. South African poverty lines: a review and two new money-metric thresholds. South African Labour and Development Research Unit Working Paper Number 151, University of Cape Town, Cape Town.
- Cheng, S.T., Chan, A.C., Fung, H.H., 2006. Factorial structure of a short version of the Center for Epidemiologic Studies Depression Scale. *International journal of geriatric psychiatry* 21, 333-336.
- Cheung, G.W., Rensvold, R.B., 2002. Evaluating goodness-of-fit indexes for testing measurement invariance. *Structural Equation Modeling* 9, 233-255.

Collins, P.Y., Patel, V., Joestl, S., March, D., Insel, T.R., Daar, A.S., 2011. Grand challenges in global mental health. *Nature* 475, 27-30.

De Villiers, L., Brow, M., Woolard, I., Daniels, R.C., Leibbrandt, M., 2013. National Income Dynamics Study Wave 3 User Manual. Southern Africa Labour and Development Research Unit, Cape Town.

Deaton, A., 1997. The analysis of household surveys: A microeconomic approach to development policy. Johns Hopkins University Press, Baltimore, Maryland.

Dohrenwend, B.P., Levav, I., Shrout, P.E., Schwartz, S., Naveh, G., Link, B.G., Skodol, A.E., Stueve, A., 1992. Socioeconomic status and psychiatric disorders: the causation-selection issue. *Science* 255, 946-952.

Filmer, D.P., P. J., 2001. Estimating wealth effects without expenditure data - or tears: An application to educational enrollments in states of India. *Demography* 38, 115-132.

Haushofer, J., Fehr, E., 2014. On the Psychology of Poverty. *Science* 344, 862-867.

Hooper, D., Coughlan, J., Mullen, M.R., 2008. Structural equation modelling: guidelines for determining model fit. *EJBRM* 6, 53-60.

Huddlestone-Casas, C., Charnigo, R., Simmons, L.A., 2009. Food insecurity and maternal depression in rural, low-income families: a longitudinal investigation. *Public Health Nutr* 12, 1133-1140.

Lancet Global Mental Health Group, 2007. Scale up services for mental disorders: a call for action. *Lancet* 370, 1241-1252.

Lund, C., Breen, A., Flisher, A.J., Kakuma, R., Corrigall, J., Joska, J.A., Swartz, L., Patel, V., 2010. Poverty and common mental disorders in low and middle income countries: A systematic review. *Social science & medicine* 71, 517-528.

Lund, C., De Silva, M., Plagerson, S., Cooper, S., Chisholm, D., Das, J., Knapp, M., Patel, V., 2011. Poverty and mental disorders: breaking the cycle in low-income and middle-income countries. *Lancet* 378, 1502-1514.

Miranda, J.J., Patel, V., 2005. Achieving the Millennium Development Goals: Does Mental Health Play a Role? *PLoS medicine* 2, 0962-0965.

Newsom, J.T., 2015. Longitudinal structural equation modeling: A comprehensive introduction. Routledge, New York.

Radloff, L.S., 1977. The CES-D scale: A self-report depression scale for research in the general population. *Applied Psychological Measurement* 1, 385-401.

Raykov, T., 2001. Estimation of congeneric scale reliability using covariance structure analysis with nonlinear constraints. *The British journal of mathematical and statistical psychology* 54, 315-323.

Saraceno, B., Itzhak, L., Kohn, R., 2005. The public mental health significance of research on socio-economic factors in schizophrenia and major depression. *World Psychiatry*. 4, 181-185.

Shrout, P.E., Yager, T.J., 1989. Reliability and validity of screening scales: Effect of reducing scale length. *Journal of Clinical Epidemiology* 42, 69-78.

Simmons, L.A., Braun, B., Charnigo, R., Havens, J.R., Wright, D.W., 2008. Depression and poverty among rural women: a relationship of social causation or social selection? *J Rural Health* 24, 292-298.

Statistics South, A., 2003. Census 2001. Statistics South Africa. Available on:

<http://www.statssa.gov.za/census01/HTML/default.asp>, Pretoria.

Townsend, P., 1987. Deprivation. *Journal of Social Policy* 16, 125-146.

Toye, M., Infanti, J., 2004. Social inclusion and community economic development: literature review. The Canadian CED Network, Victoria, BC.

Unit, S.A.L.a.D.R., 2014. National Income Dynamics Study 2012, Wave 3. Southern Africa Labour and Development Research Unit (producer); DataFirst (distributor), Cape Town.

Whiteford, H.A., Degenhardt, L., Rehm, J., Baxter, A.J., Ferrari, A.J., Erskine, H.E., Charlson, F.J., Norman, R.E., Flaxman, A.D., Johns, N., Burstein, R., Murray, C.J., Vos, T., 2013. Global burden of disease attributable to mental and substance use disorders: findings from the Global Burden of Disease Study 2010. *Lancet* 382, 1575-1586.

Wood, A.M., Taylor, P.J., Joseph, S., 2010. Does the CES-D measure a continuum from depression to happiness? Comparing substantive and artifactual models. *Psychiatry research* 177, 120-123.

World Bank, 2015a. World Bank Gini Index.

World Bank, 2015b. World Development Report 2015: Mind, Society and Behavior. World Bank, Washington, DC.

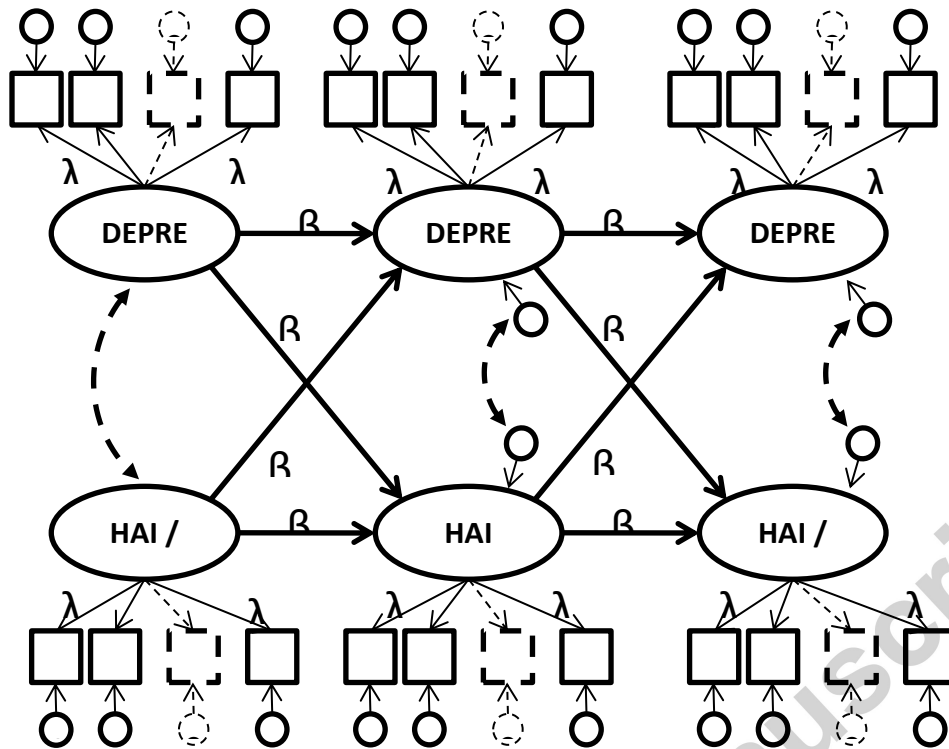

Figure 1 Path diagram for the structural equation model used to estimate the relationships between depression and household or individual assets across the three waves of NIDS. Squares and ellipses represent observed and latent variables, respectively. Arrows indicate hypothesised causal effects and double-headed arrows non-causal correlations due to external variables not included in the model. Circles represent error residuals. Relationships between each latent variable and their categorical indicators (measurement model) are described by a series of probit regression equations with coefficient λ_i (factor loadings). Relationships between latent variables (structural model) are modelled as linear, with regression coefficients β_j . The hypothesis of stability of the relationships between latent depression and household or individual assets during the study period is included in the model by constraining the structural coefficients β_j to be equal across waves, as indicated in the figure. Residuals of corresponding indicators were allowed to correlate across measurement occasions (not shown in the figure). Gender, race, age and educational level are omitted from the diagram, but taken into account as possible confounders in

the estimation of the model. The same model was fitted to study the relationships between depression and household (HAI) or individual (IAI) asset indices.

Table 1 Sample descriptive statistics at wave 1.

Variable	N	Median / percentage	Frequency / IQR	Range
Men	11440	39.12%	4475	
Age [years]	11439	35	[22 ; 50]	[15 ; 101]
Race	11440			
Black		81.74%	9351	
Coloured		13.95%	1596	
White		3.09%	354	
Asian		1.22%	139	
Completed education	11431			
None		13.86%	1584	
Primary (1 - 7 years)		25.35%	2898	
Secondary (8 – 13 years)		53.57%	6124	
Tertiary (> 13 years)		7.22%	825	
Place of residence	11440			
Urban		45.0%	5148	
Rural		55.0%	6292	

Household monthly income	11440			
per capita [ZAR]				
Quintile I	2287	800	[511 , 1019]	[0 , 1158]
Quintile II	2288	1486	[1311 , 1690]	[1159 , 1902]
Quintile III	2289	2311	[2104 , 2572]	[1903 , 2935]
Quintile IV	2287	3813	[3290 , 4403]	[2936 , 5292]
Quintile V	2289	8560	[6602 , 13131]	[5300 , 112000]
Employment status	11340			
Employed		37.25%	4224	
Unemployed		19.44%	2204	
Not economically active		43.32%	4912	

N = number of non-missing values; IQR= interquartile range; ZAR = South African Rand (1 USD \approx 8.25 ZAR, average 2008 exchange rate).

Table 2 Distribution of CESD-10 scores in the sample at each wave.

	Wave 1	Wave 2	Wave 3
N	10394	10352	10127
Median	7	6	6
IQR	[5 - 11]	[4 - 10]	[4 - 10]
Range	[0 - 30]	[0 - 30]	[0 - 30]
Percentage of subjects with CESD-10 scores >12	15.82%	11.43%	12.45%

N = Number of non missing values; IQR = Interquartile range. Missing responses in individual items were imputed based on the mean score obtained in the remaining items.

Table 3 Standardised linear regression coefficients for the structural relationships between individual and household asset indices and depression.

	Structural Relationship	β	SE
Individual Asset Index	Depression ₁ → Depression ₂	0.076	0.019
	Depression ₂ → Depression ₃	0.075	0.018
	Depression ₁ → Assets ₂	-0.037	0.016
	Depression ₂ → Assets ₃	-0.028	0.012
	Assets ₁ → Depression ₂	-0.110	0.024
	Assets ₂ → Depression ₃	-0.113	0.025
	Assets ₁ → Assets ₂	0.836	0.025
	Assets ₂ → Assets ₃	0.668	0.032
Household Asset Index	Depression ₁ → Depression ₂	0.075	0.018
	Depression ₂ → Depression ₃	0.074	0.018
	Depression ₁ → Assets ₂	-0.006	0.011
	Depression ₂ → Assets ₃	-0.004	0.008
	Assets ₁ → Depression ₂	-0.053	0.019
	Assets ₂ → Depression ₃	-0.084	0.030
	Assets ₁ → Assets ₂	0.808	0.014
	Assets ₂ → Assets ₃	0.921	0.241

β = Linear regression coefficient; SE = Standard error. Subscripts indicate the wave to which the values refer. Statistically significant coefficients in bold.

Highlights

- Many of the proposals to address the major population level burden of depression in low and middle-income countries (LMIC) have focused on attempts to scale up mental health treatment services, addressing the social drift pathway.
- The notion that social causation and social drift might occur simultaneously in the case of depression has not been addressed in global mental health research, either as a potential area for further research enquiry or an approach to adopt in policy.
- We analysed nationally representative longitudinal data from the National Income Dynamics Study in South Africa and simultaneously tested social causation and social drift hypotheses using structural equation modelling across three waves.
- The significance of our findings are that household poverty is a predictor of subsequent worsening of depression status and depression appears also to play a significant role in exacerbating conditions of individual poverty in South Africa, particularly for people with less economic resources.
- This is the first time, to our knowledge that a nationally representative longitudinal study has examined both social causation and social drift in a LMIC, and the first study to demonstrate that both social causation and social drift act simultaneously on a given population, further reinforcing the poverty/depression relationship.